



UNINTERRUPTIBLE POWER SUPPLY SYSTEM

MODEL

**9900 AEGIS SERIES**

**w/ Enviro-STS**

OWNERS / TECHNICAL MANUAL

# Preface

---

**TABLE OF CONTENTS**

LIST OF TABLES .....	ii
LIST OF FIGURES .....	iii
HOW TO USE THIS MANUAL .....	iv
<b>1.0 INTRODUCTION .....</b>	<b>1-1</b>
1.1 SAFETY PRECAUTION .....	1-2
1.2 GENERAL .....	1-5
1.3 DEFINITIONS .....	1-6
1.4 OPERATION OVERVIEW .....	1-7
1.5 SPECIFICATIONS .....	1-14
<b>2.0 OPERATION CONTROLS AND INDICATORS .....</b>	<b>2-1</b>
2.1 LED DISPLAY .....	2-2
2.2 EPO BUTTON .....	2-2
2.3 LIQUID CRYSTAL DISPLAY .....	2-3
2.4 EXTERNAL SIGNAL TERMINAL BLOCK .....	2-9
2.5 EXTERNAL COMMUNICATION CONNECTOR .....	2-14
<b>3.0 INSTALLATION AND OPERATION .....</b>	<b>3-1</b>
3.1 TRANSPORTATION AND INSTALLATION .....	3-1
3.2 INSTALLATION PROCEDURE .....	3-1
3.3 PROCEDURE FOR CABLE CONNECTIONS .....	3-2
3.4 OPERATING PROCEDURES .....	3-12
<b>4.0 RESPONSE TO UPS FAILURE .....</b>	<b>4-1</b>
<b>5.0 PARTS REPLACEMENT .....</b>	<b>5-1</b>
<b>6.0 FAULT CODES .....</b>	<b>6-1</b>
<b>7.0 WARRANTY &amp; OUT OF WARRANTY SERVICE .....</b>	<b>7-1</b>

**LIST OF TABLES**

Table 1.1	UPS Installation Environment.....	1-3
Table 1.2	Rating of Bypass Input Circuit Breaker .....	1-4
Table 1.3	Power Specifications .....	1-14
Table 1.4	UPS Module Information .....	1-14
Table 1.5	Detail of Specifications .....	1-15
Table 1.6	Rating of Contactors, Breakers and Fuses .....	1-16
Table 3.1	How to Transport and Install the System.....	3-1
Table 3.2	List of UPS Weights (lb.) .....	3-1
Table 3.3	Maximum Permitted (DC) Fault Current .....	3-2
Table 3.4	Recommended Cable Sizes .....	3-5
Table 3.5	Crimp Type Compression Lug.....	3-6
Table 6.1	Fault Code.....	6-2

**LIST OF FIGURES**

Figure 1.1	Single Line Diagram-Normal Operation .....	1-7
Figure 1.2	Single Line Diagram-Bypass Operation.....	1-8
Figure 1.3	Single Line Diagram-Battery Operation .....	1-9
Figure 1.4	Single Line Diagram-Enviro-mode Operation .....	1-10
Figure 1.5-a	UPS Parts Location (80/100/150/160kVA).....	1-12
Figure 1.5-b	UPS Parts Location (225kVA).....	1-13
Figure 2.1	Operation/Display Panel.....	2-1
Figure 2.2	Main Screen .....	2-3
Figure 2.3-a	Startup/Shutdown guidance .....	2-4
Figure 2.3-b	Startup guidance .....	2-4
Figure 2.3-c	Shutdown guidance .....	2-4
Figure 2.4-a	Input values .....	2-4
Figure 2.4-b	Output values .....	2-5
Figure 2.4-c	Values battery operation.....	2-5
Figure 2.5-a	Remote/Local operation select .....	2-5
Figure 2.5-b	Date & Time adjustment .....	2-5
Figure 2.6-a	Status menu .....	2-6
Figure 2.6-b	Event log .....	2-6
Figure 2.6-c	Battery log .....	2-6
Figure 2.7-a	Main Screen (Battery Operation).....	2-7
Figure 2.7-b	Measurement Screen (Battery Operation).....	2-7
Figure 2.8	Main Screen (Fault Indication).....	2-7
Figure 2.9	Message Screen.....	2-8
Figure 2.10-a	External Signal Terminal Block (TN2) .....	2-9
Figure 2.10-b	External Signal Terminal Block (TN1) .....	2-10
Figure 2.11	Control Wiring for External Contacts .....	2-11
Figure 2.12	Remote "Start" Contact Connections.....	2-12
Figure 2.13	External communication connector.....	2-14
Figure 3.1	UPS Terminal Designation .....	3-6
Figure 3.2	Diagram of input/output bus bars and terminal blocks .....	3-7
Figure 3.3	Diagram of Power wire & Control wire Inter-connect between UPS and Battery ....	3-8
Figure 3.4	Cable Entry on Bottom (Example of 225kVA).....	3-9
Figure 3.5	Cable Entry on Top (Example of 225kVA).....	3-9
Figure 3.6	Diagram of Power wire Connect (Parallel Connection).....	3-10
Figure 3.7	Diagram of Power and Control wire Connect (Parallel Connection) .....	3-11
Figure 3.8	LCD Screen (MMS Operation).....	3-15
Figure 3.9	Operation Menu (Enviro-mode available) .....	3-16
Figure 3.10-a	Enviro-mode select (OFF) .....	3-16
Figure 3.10-b	Enviro-mode select (ON) .....	3-16
Figure 3.11	Enviro-mode Operation .....	3-17

## HOW TO USE THIS MANUAL

This manual is designed for ease of use, giving the user easy and quick reference to information.

This manual uses notice icons to draw attention to the user important information regarding the safe operation and installation of the UPS. The notice icons used in this manual are explained below, and should be taken into account and adhered to whenever they appear in the text of this manual.



**Warning:** A warning notice icon conveys information provided to protect the user and service personnel against hazards and/or possible equipment damage.



**Caution:** A caution notice icon conveys information provided to protect the user and service personnel against possible equipment damage.



**Note:** A Note notice icon indicates when the user should make a reference of information regarding the UPS operation, load status and display status. Such information is essential if Mitsubishi field service group assistance and correspondence is required.

**Safety Recommendations:** If any problems are encountered while following this manual, Mitsubishi field service group assistance and correspondence is recommended.

## 1.0 INTRODUCTION

The Mitsubishi Uninterruptible Power Supply System (UPS) is designed to provide many years of reliable protection from power failure, brown-outs, line noise, and voltage transients. To ensure optimum performance of the equipment, follow the manufacturer's instructions. This manual contains descriptions required to operate the UPS. Please read this manual carefully and retain it for future reference.

**IMPORTANT SAFETY INSTRUCTIONS**  
**SAVE THESE INSTRUCTIONS**



This manual contains important instructions for the 9900AEGIS SERIES Uninterruptible Power Supply Systems that should be followed during installation and maintenance of the UPS and batteries.

**WARNING 1**



**Lethal voltages exist within the equipment during operation. Observe all warnings and cautions in this manual. Failure to comply may result in serious injury or death. Obtain qualified service for this equipment as instructed.**

**WARNING 2**

In no event will MITSUBISHI be responsible or liable for either indirect or consequential damage or injury that may come from the use of this equipment.

Any modifications without authorization by MITSUBISHI could result in personal injuries, death or destruction of the UPS.

**1.1 SAFETY PRECAUTIONS****APPLICATION**

If the UPS System is to be applied to support equipment that could affect human safety, the following steps must be adhered to:

1. Consult with Mitsubishi Electric Power Products Inc. UPS Division.
2. Special consideration of the overall back up power system configuration is required so that the Mitsubishi UPS System is not the sole support required for operation, maintenance and management of power availability. Other available power sources; for example utility, emergency power generation or other systems shall also support power availability.

Definition of equipment that could affect human safety:

- Life Support Systems (is a system whose failure to perform can be expected to result in bodily injury or death.)
- Essential Public Systems (is a system whose failure to perform can be expected to result in bodily injury or death and/or property damage.)



**WARNING 3**


**The UPS is to be installed in a controlled environment.**

**Improper storage and installation environment may deteriorate insulation, shorten component life and cause malfunctions.**

**Keep the installation environment per standard described as follows:**

**TABLE 1.1 UPS Installation Environment**

No.	Item	Environment standard	
1	Installation location	Indoors	
2	Ambient temperature	Minimum temperature: 32°F(0°C), Maximum temperature: 104°F(40°C) The average temperature over any 24-hour period must be in the range 41° F (5°C) to 95°F(35°C).	
3	Relative humidity	The relative humidity must be held between 5 and 95%. There must be no condensation due to temperature changes.	
4	Altitude	This equipment must not be applied at altitude that exceeds 2250m(7400ft) above seal level.	
5	Dust	Dust in the room where the UPS is installed must not exceed normal atmospheric dust levels. In particular, that dust should not include iron particles, oils or fats, or organic materials such as silicone.	
6	Inflammable gas following IEC654-4 Part 4	There should be no inflammable/explosive gas.	
		Hydrogen sulfide (H <sub>2</sub> S)	No more than 0.003 PPM
		Sulfurous acid gas (SO <sub>2</sub> )	No more than 0.01 PPM
		Chlorine gas (Cl <sub>2</sub> )	No more than 0.002 PPM
		Ammonia gas (NH <sub>3</sub> )	No more than 1 PPM
		Nitrous oxides (NO <sub>x</sub> )	No more than 0.05 PPM
		Ozone (O <sub>3</sub> )	No more than 0.002 PPM

**WARNING 4**

This UPS does not include a Bypass input circuit breaker (MCCB) to protect bypass circuit. The Bypass input circuit breaker (MCCB) is to be field supplied and installed. Recommended Breaker (MCCB)'s Specifications are as follows:

**TABLE 1.2** Rating of Bypass Input Circuit Breaker

Capacity (kVA)	Bypass Voltage (Vac)	Bypass Rating (Aac)	Breaker (A)
80	480	96	120
100	480	120	150
150	480	180	250
160	480	192	250
225	480	271	350

AC input and AC output overcurrent protection and disconnect devices shall be field supplied and installed by others. The DC circuit breaker (MCCB) shall be field supplied and installed by others. The overcurrent protection device should be installed in the Battery cabinet and rated as indicated in TABLE 1.6.

**Note:** The DC input overcurrent protection (Battery disconnect breaker) hereinafter will be referred as "CB2".

## **1.2 GENERAL**

The Mitsubishi 9900AEGIS SERIES UPS provides continuous and clean electrical power to a critical load. Additionally the UPS monitors the critical load's power conditions, and in the event of an input power failure, the UPS will maintain power to the critical load for the specified battery run-time.

Back up power from the UPS battery permits the orderly shutdown of equipment supported by the UPS.

The 9900AEGIS SERIES UPS is available in Five kVA sizes - 80, 100, 150, 160 and 225kVA. Specifications for each kVA model appear in Section 1.5. The principles of operation described herein are applicable to all models.

This manual provides an overview of the 9900AEGIS SERIES components and their functions. The appearance and purpose of operator controls and indicators is described with procedures for operation, start-up, shutdown and basic maintenance is included.

### 1.3 DEFINITIONS

**UNINTERRUPTIBLE POWER SUPPLY SYSTEM (UPS)** - All components within the UPS Module Cabinet and associated batteries that function as a system to provide continuous, conditioned AC power to a load, (often) referred to as the "System".

**UPS MODULE CABINET** - The metal enclosure which contains the Converter / Charger, Inverter, Static Transfer Switch, Internal Bypass line, operator controls, and internal control systems required to provide specified AC power to a load.

**UPS MODULE** - The Converter / Charger and Inverter assemblies which, under the direction of the internal control system and operator controls, provide specified AC power to a load.

**INVERTER** - The UPS components which contain the equipment and controls necessary to convert DC power from the Converter / Charger, or the battery, to AC power required by the critical load.

**CONVERTER / CHARGER** - The UPS components which contain the equipment and controls necessary to convert input AC power to regulated DC power required for battery charging and for supplying power to the Inverter.

**STATIC TRANSFER SWITCH (STS)** - The device which connects the critical load to the bypass line when the Inverter cannot supply continuous power.

**ENVIRO-STATIC TRANSFER SWITCH (ESTS)** - The device which has continuous-rating thyristors and connects the critical load with the bypass source directly so that the UPS can operate in an extremely high efficiency mode. (Enviro-mode)

**BYPASS LINE** - The line which conducts electricity directly from the input power source to the critical load during Maintenance or whenever the UPS is not completely operational.

**AC INPUT POWER** - Power provided by the electrical utility company, or auxiliary generator, which is connected to the UPS for supplying the critical load.

**BATTERY** - The rechargeable battery strings which supply DC power to the inverter to maintain continuous AC power to the load during AC input power failure conditions.

## 1.4 OPERATION OVERVIEW

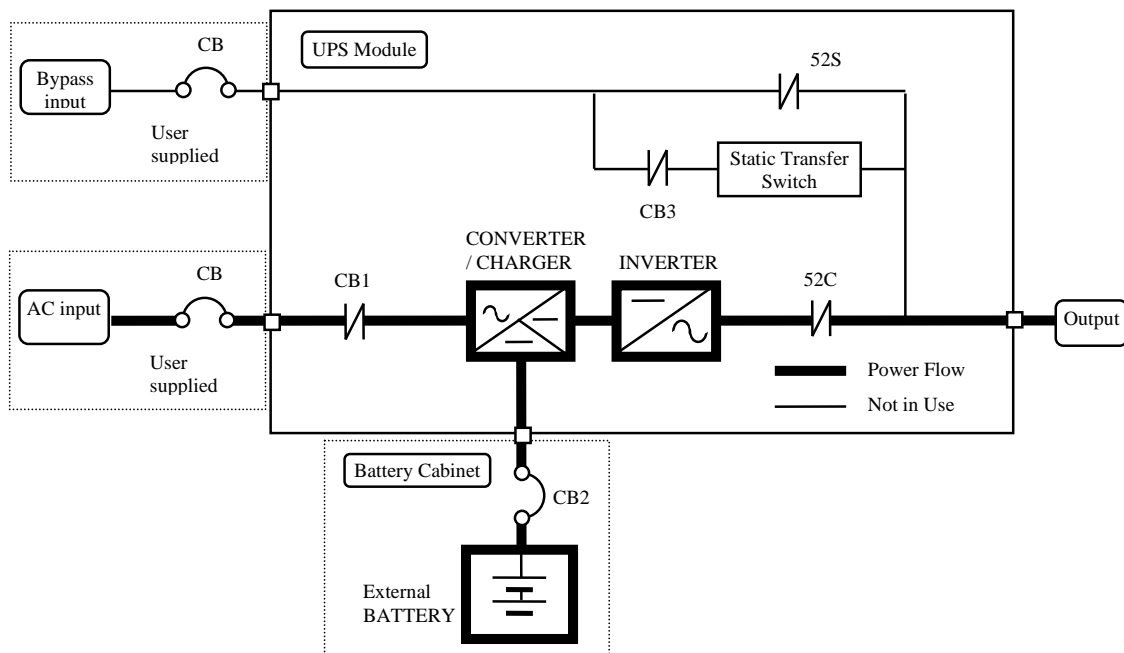
The UPS provides two power paths between the utility source and the critical load.

Figure 1.1 shows the path for normal operation, with the load powered from the inverter,

Figure 1.2 shows the path for bypass operation, with the load supplied through the static bypass line, and Figure 1.4 shows the power supply path in Enviro-mode operation, where the critical load is supplied from bypass power through the ESTS.

**A) Normal operation:** Load power supplied by each system UPS inverter.

**Figure 1.1** Single Line Diagram - Normal Operation: Load powered by UPS inverter



During normal operation, the path through the UPS inverters is used to power the load.

Referring to Figure 1.1: Input AC power is converted to DC by the Converter. DC power is utilized to charge the UPS battery and to provide power to the Inverter. The Inverter converts the DC power to clean AC power to supply the critical load.

The conversion - inversion process eliminates any voltage transients or fluctuations existing in the input power before it reaches the critical load.

The power drawn by the critical load is equally shared between all UPS whenever the system is in the Parallel Operation. (Refer to Figure 3.6 that shows a sample of Parallel Operation System Configuration.)

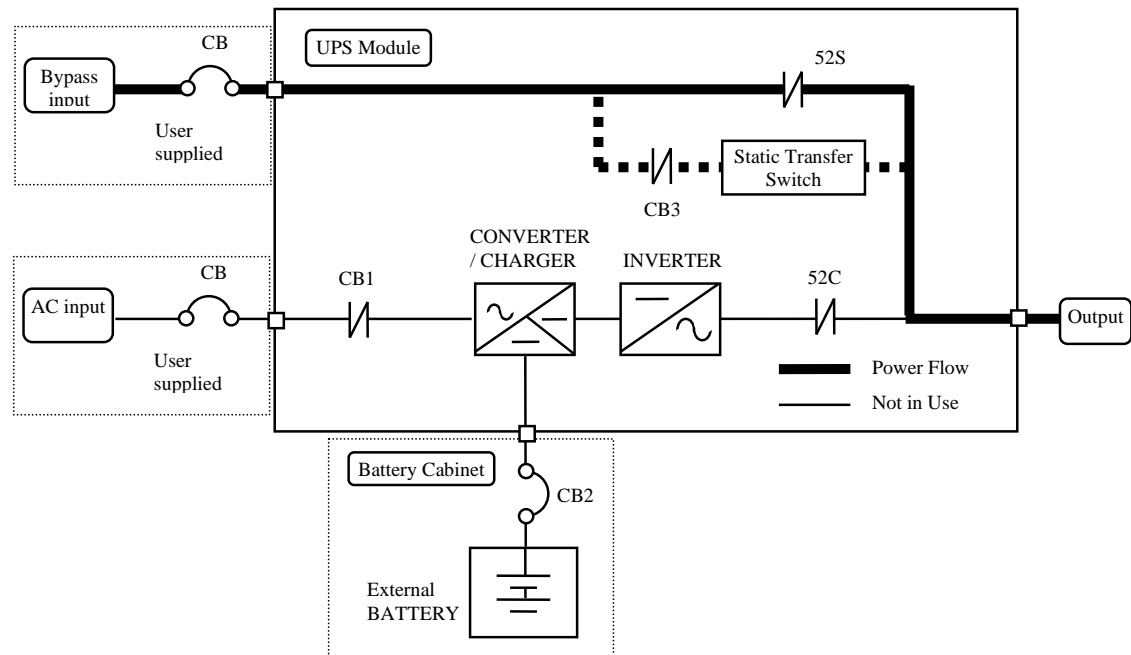
In the event of a UPS module failure during Parallel Operation, the critical load power will be continually supplied and shared by all other UPS.



*The Bypass Input circuit breaker (MCCB) for protection of the UPS and cables are field supplied and field installed. (See WARNING 4 on page 1-4)*

**B) Bypass Operation:** Load Power supplied through UPS internal static bypass line.

**FIGURE 1.2** Single Line Diagram - Bypass Operation: Load fed through static bypass line.



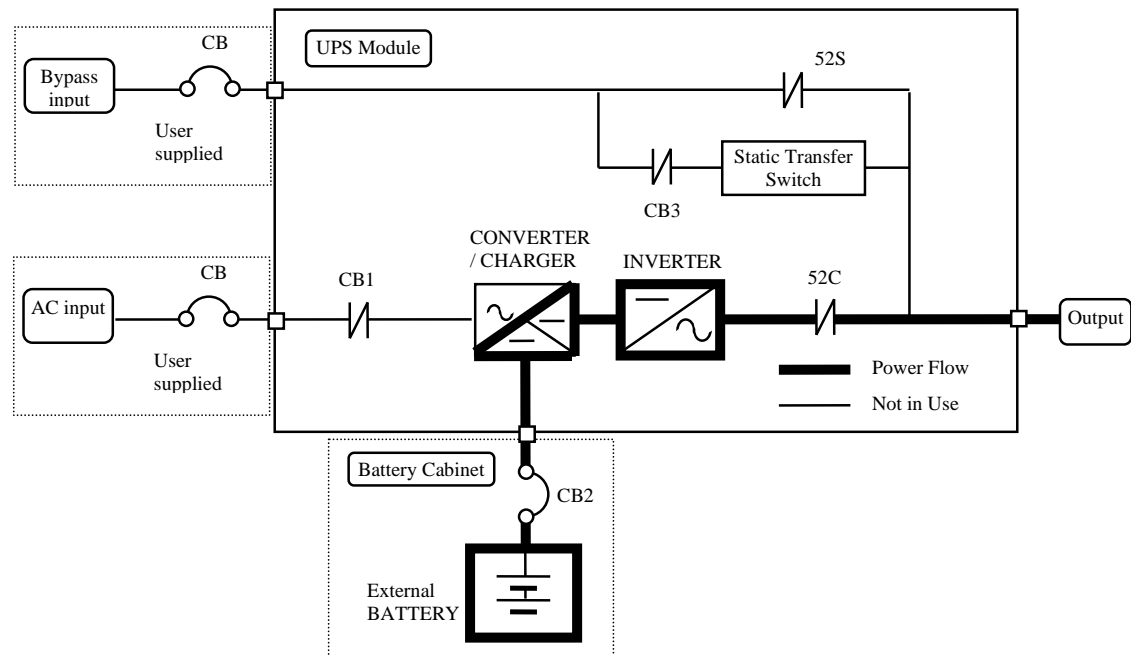
Referring to Figure 1.2: The Internal Bypass line is a Hard-wired line through 52S which supplies the critical load with unconditioned bypass input power. Upon switching to the Internal Bypass line, the Static Transfer Switch line through CB3 (herein after STS contactor CB3) supplies the power immediately, and then the Internal Bypass line through 52S supplies the power. In the event of a switching to the Bypass line, the power to the critical load will be uninterrupted. The purpose of this Internal Bypass line is to route power to the critical load while the UPS module is de-energized (converter and inverter), and during Start-up before the system is fully operational.

Each UPS internal static bypass line will equally share the power supplied to the critical load whenever the system is in the Parallel Operation.

In the event of a load overcurrent, the UPS transfers to bypass without interruption to the critical load. In the case of the Parallel Operation, all UPS will transfer to bypass without interruption to the critical load. The internal control system determines the operation of the two paths, with the load powered from the inverter being the normal operation.

**C) Battery operation:** Load Power supplied by UPS battery.

**FIGURE 1.3** Single Line Diagram - Battery Operation



Referring to Figure 1.3: In the event of AC input source failure or interruption, the UPS Converter(s)\* will de-energize and the UPS battery(s)\* will discharge supplying DC power to the Inverter to maintain continuous AC power to the load. This operation will continue until:

- The battery capacity expires (the end voltage is reached) and the inverter turns off, or
- Input power is restored after which the converter will power the inverter, critical load and recharge the batteries.

A fully charged battery will provide power for the specified time at the rated load, or longer, at a reduced load.

(s)\* : In the case of the Parallel Operation

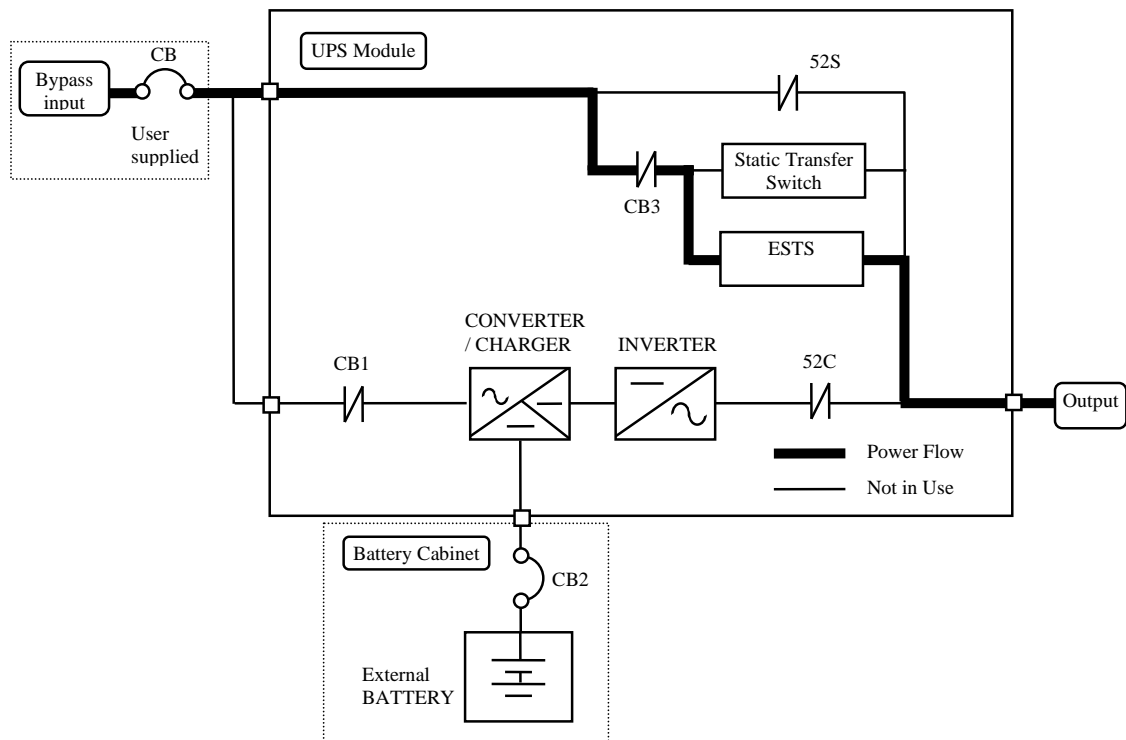
When power is restored after a low battery shutdown, the UPS converter(s)\* automatically restarts operation, the charger(s)\* recharges the batteries and the Inverter(s)\* is automatically restarted without operator intervention. Load is automatically assumed by the inverter without operator intervention.

(s)\* : In the case of the Parallel Operation

Whenever the system is in the Parallel Operation, the power drawn by the load is equally shared between all UPS regardless of the presence or absence of the UPS that is (are) in battery operation.

**D) Enviro-mode Operation:** Load Power supplied from bypass through the ESTS.

**FIGURE 1.4** Single Line Diagram – Enviro-mode Operation

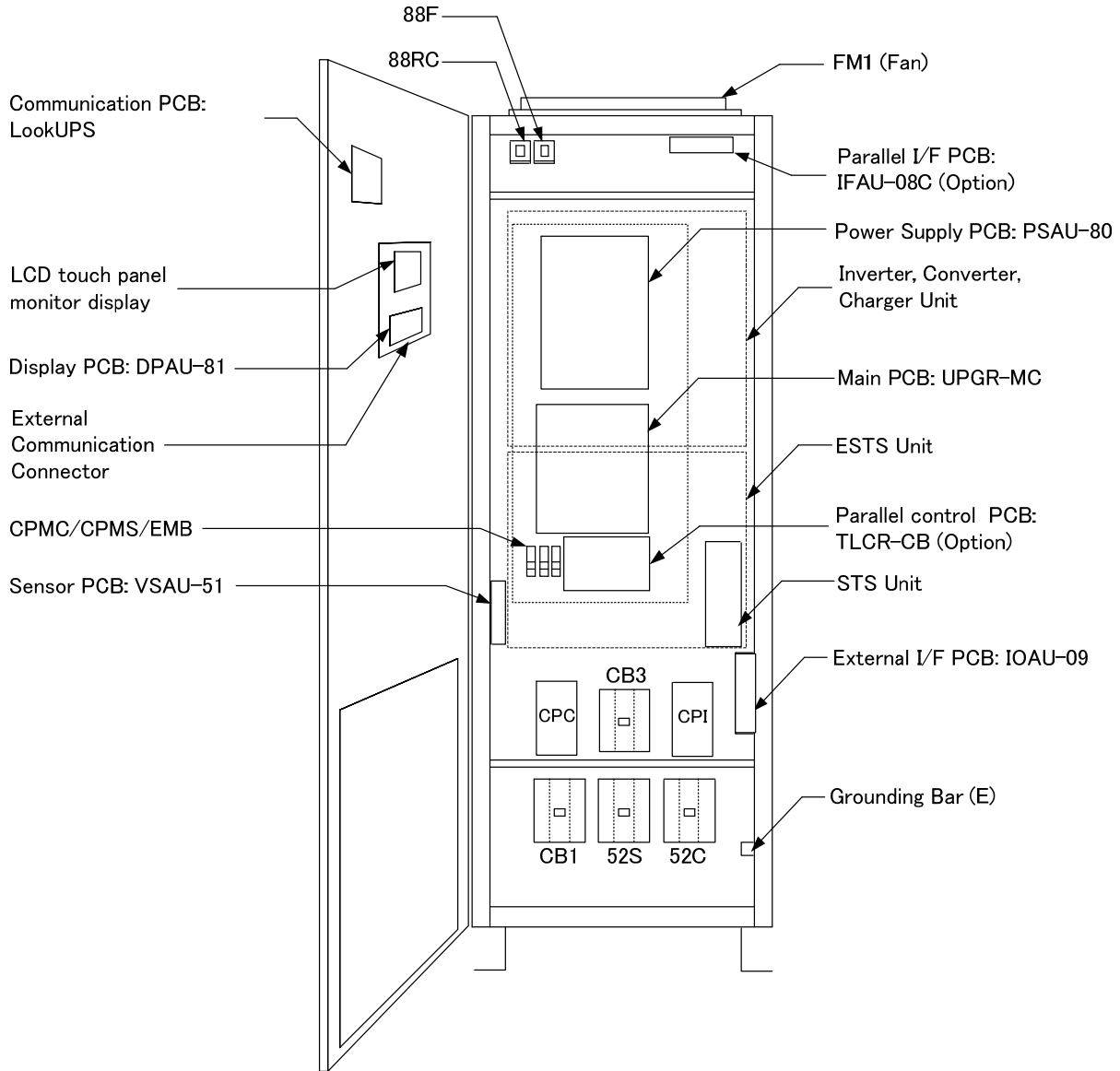


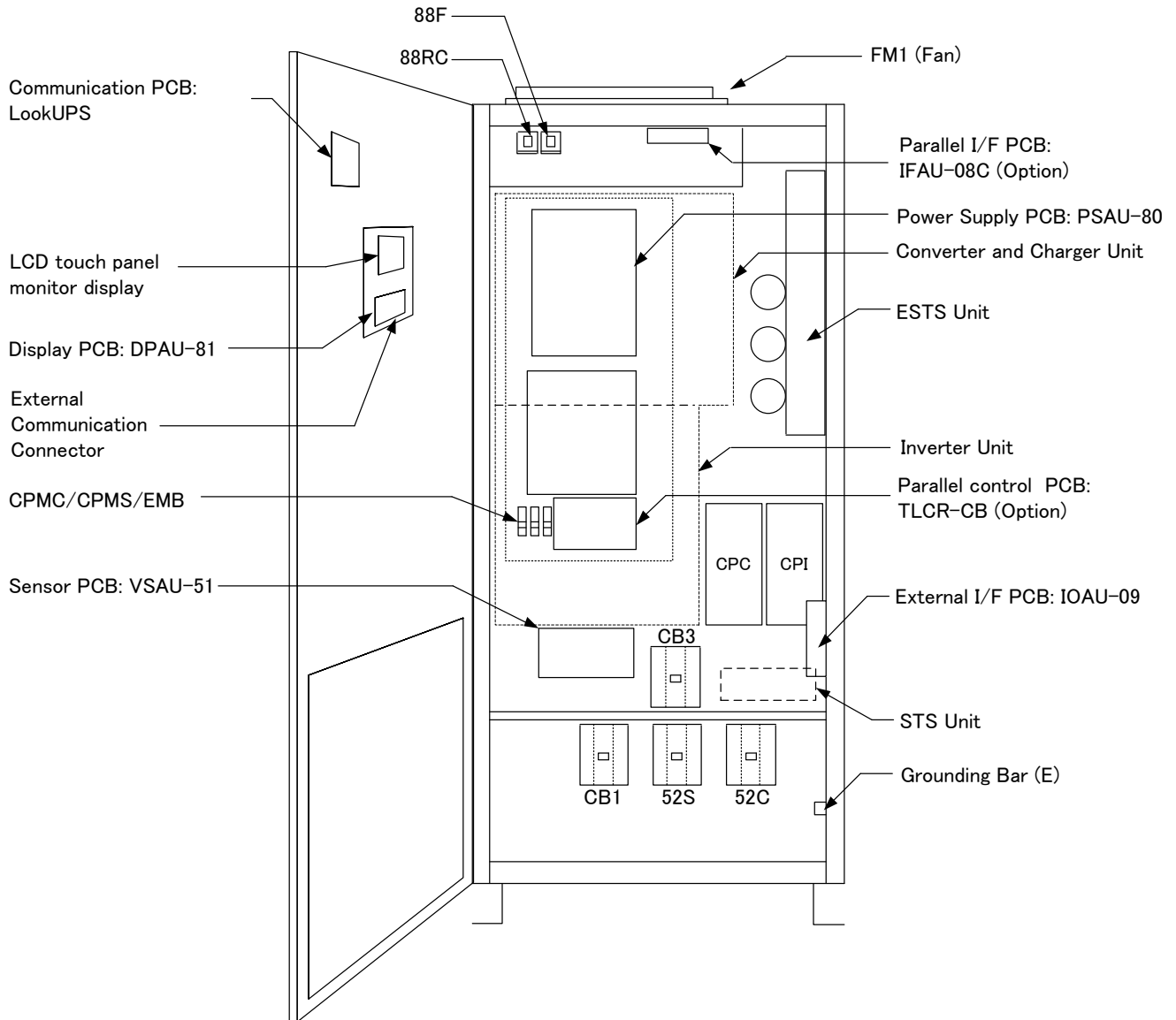
Referring to Figure 1.4: The ESTS consists of thyristors rated enough to continuously supply the UPS's rated power from mains to the load. The critical load is directly supplied by the UPS through the ESTS. This operating mode enables the UPS to obtain a high efficiency. Once UPS input becomes abnormal, the UPS automatically transfers to the inverter operation within 4ms.





Enviro-mode is effective ONLY on SMS (Single Module System) with the same power source for Bypass and AC input.

**FIGURE 1.5-a UPS Parts Location (80/100/150/160kVA)**


**FIGURE 1.5-b UPS Parts Location (225kVA)**


## 1.5 SPECIFICATIONS

The UPS nameplate displays the rated kVA as well as nominal voltages and currents. The nameplate is located on the inside of the UPS front door.

**TABLE 1.3** Power Specifications

<b>Rated output Power</b>	<b>Input voltage 3 phase / 3 wire</b>	<b>Bypass input voltage 3 phase / 3 wire</b>	<b>Output voltage 3 phase / 3 wire</b>
80kVA / 72kW	480V	480V	480V
100kVA / 90 kW	480V	480V	480V
150kVA / 135kW	480V	480V	480V
160kVA / 144kW	480V	480V	480V
225kVA / 202.5kW	480V	480V	480V

**TABLE 1.4** UPS Module Information

<b>UPS [kVA]</b>	<b>Cable Entry</b>	<b>Width [in / mm]</b>	<b>Depth [in / mm]</b>	<b>Height [in / mm]</b>	<b>Weight [lb./ kg]</b>	<b>Heating at 100% load [kBTU / h]</b>
80	BOTTOM	27.6 / 700	32.8 / 832	80.6 / 2047	801 / 363	8.6
100	BOTTOM	27.6 / 700	32.8 / 832	80.6 / 2047	801 / 363	10.8
150	BOTTOM	27.6 / 700	32.8 / 832	80.6 / 2047	893 / 405	17.2
160	BOTTOM	27.6 / 700	32.8 / 832	80.6 / 2047	893 / 405	18.3
225	BOTTOM	35.4 / 900	32.8 / 832	80.6 / 2047	1119 / 508	22.8

**TABLE 1.5** Detail of Specifications

Rated Output kVA	80	100	150	160	225
Rated Output kW	72	90	135	144	202.5
<b>AC INPUT</b>					
Configuration	3 phase, 3 wire				
Voltage	480 V +15% to -20%				
Frequency	60 Hz +/-10%				
Reflected Current THD	3% at 100% load (no input filter required)				
<b>STATIC BYPASS INPUT</b>					
Configuration	3 phase, 3 wire				
Voltage	480 V +/-10%				
Frequency	60 Hz +/-5%				
<b>BATTERY</b>					
Type	Lead Acid				
Ride Through	Application Specific				
Nominal Voltage	480 Vdc				
Minimum Voltage	400 Vdc				
Number of Cells	240				
<b>AC OUTPUT</b>					
Configuration	3 phase, 3 wire				
Voltage	480 V				
Voltage Regulation	+/-1%				
Frequency	60 Hz				
Frequency Regulation	+/-0.01 in free running mode				
Power Factor	0.9 nominal				
Power Factor Range	0.9 to 1.0 lagging (within output kW rating)				
Voltage THD	2% maximum THD at 100% Linear Load 5% maximum THD at 100% non-linear load				
Transient Response	+/-2% maximum at 100% load step +/-1% maximum at loss/return of AC power +/-5% maximum at load transfer to/from static bypass				
Transient Recovery	Less than 20ms				
Voltage Unbalance	1% maximum at 100% unbalanced load				
Phase Displacement	1 deg. maximum at 100% load				
Inverter Overload	125% for 2 minutes; 150% for 60 seconds				
Bypass Overload	1000% for 1 cycle (with bypass available)				
<b>ENVIRONMENTAL**</b>					
Cooling	Forced Air				
Operating Temperature	32° F to 104° F ( 0° C to 40° C). Recommended : 68° F to 86° F ( 20° C to 30° C)				
Relative Humidity	5% ~ 95% Non Condensing				
Altitude	0 to 7400 feet No Derating at 40° C				
Location	Indoor (free from corrosive gases and dust)				
Paint Color	Munsell 5Y7/1 (Beige)				

\*\*Indication that the unit is intended for installation in a temperature-regulated, indoor area that is relatively free of conductive contaminants.

**TABLE 1.6** Rating of Contactors, Breaker and Fuses

	NUMBER	APPLICATION	OUTPUT CAPACITY OF EQUIPMENT				
			80kVA	100kVA	150kVA	160kVA	225kVA
			72kW	90kW	135kW	144kW	202.5kW
Contactor	CB1	AC input contactor	135A	135A	200A	200A	260A
	CB3	STS contactor	135A	135A	200A	200A	260A
	52C	Inverter output contactor	135A	135A	200A	200A	260A
	52S	Bypass contactor	135A	135A	200A	200A	260A
	88RC	Control circuit contactor	20A	20A	20A	20A	20A
Breaker	User supply* (CB2)	Battery disconnect breaker ( <i>Recommended</i> )	200A	250A	400A	400A	600A
	User supply*	AC input breaker ( <i>Recommended</i> )	120A	150A	250A	250A	350A
	User supply*	AC output breaker ( <i>Recommended</i> )	120A	150A	250A	250A	350A
Fuses	FCC, FCI	DC fuse	315A / 690V	315A / 690V	315A / 690V	315A / 690V	315A / 690V
	FP	DC fuse	315A / 1300V	315A / 1300V	400A / 1300V	400A / 1300V	630A / 1300V
	FRU, V, W	Control power fuse	30A / 600V	30A / 600V	30A / 600V	30A / 600V	30A / 600V
	FSU, FSV, FSW**	Bypass input fuse	315A / 690V	315A / 690V	400A / 500V	400A / 500V	315A / 690V
	FBU, V, W	Control power fuse	30A / 600V	30A / 600V	30A / 600V	30A / 600V	30A / 600V
	FEA, FEB, FEC**	Parallel control circuit fuse	3A / 600V	3A / 600V	3A / 600V	3A / 600V	3A / 600V

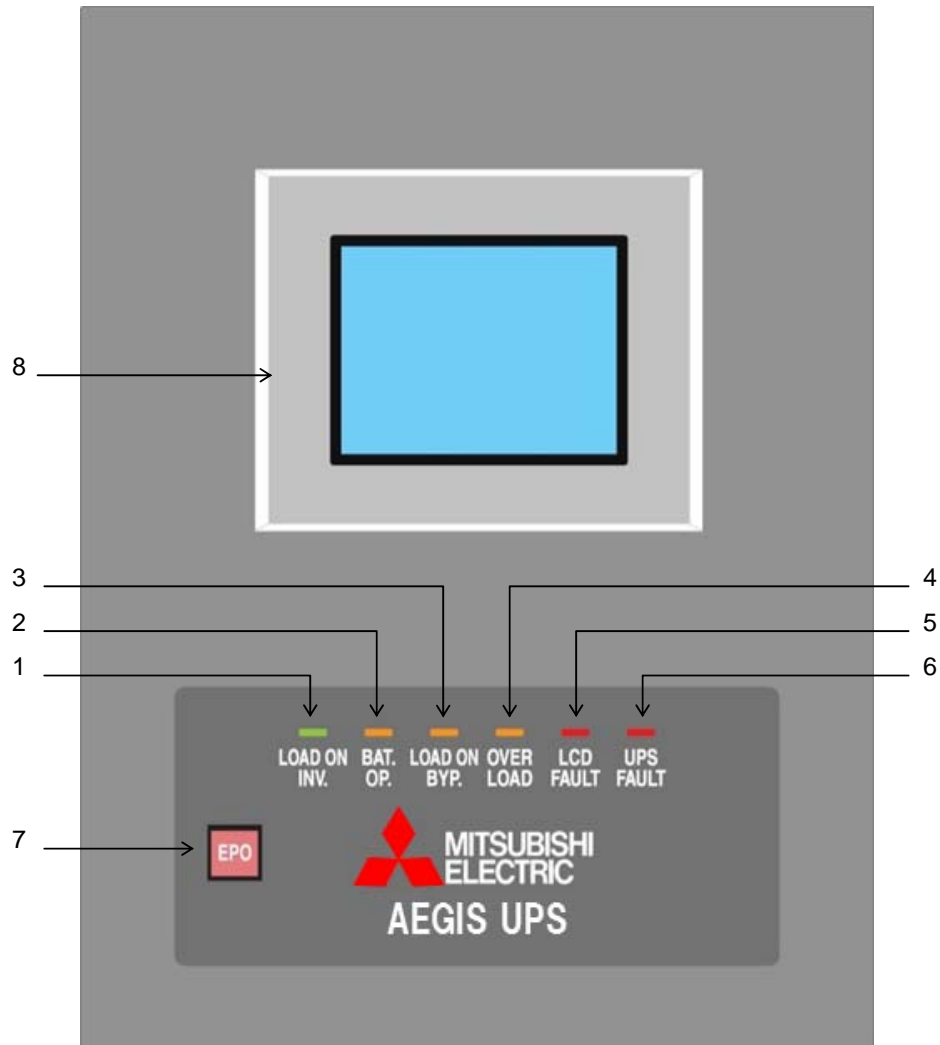
\*Regarding DC and Output overcurrent protection, its rating and disconnect devices shall be provided by others on all ungrounded conductors.

\*\*Option

## 2.0 OPERATOR CONTROLS AND INDICATORS

The 9900AEGIS Series operator controls and indicators are located as follows (Door exterior) :

**FIGURE 2.1** Operation/Display Panel (Front panel)



## 2.1 LED DISPLAY

1) **Load on inverter [ LOAD ON INVERTER ](green)**

Illuminates when power is supplied from inverter to the critical load.

(Indicates the state of inverter transfer switch "52C".)

2) **Battery operation [ BATTERY OP. ](orange)**

Illuminates when power is supplied from batteries following a power failure.

3) **Load on bypass [ LOAD ON BYPASS ](orange)**

Illuminates when power is supplied to load devices by static bypass.

(Indicates the state of bypass transfer switch "52S".)

4) **Overload [ OVERLOAD ](orange)**

Illuminates in overload condition.

5) **LCD fault [ LCD FAULT ](red)**

Illuminates when an error occurs.

6) **UPS fault [ UPS FAULT ](red) [Annunciator: intermittent or constant tones]**

Illuminates when an error occurs in the system. In this case, the details of the error are indicated on the display panel.

## 2.2 EPO BUTTON (Emergency Power Off button) (7)

When activated, the Emergency Power Off (EPO) function shuts down the UPS module. The critical load will lose power and also shutdown. The EPO function can be performed both locally or remotely.



## 2.3 LIQUID CRYSTAL DISPLAY (8)

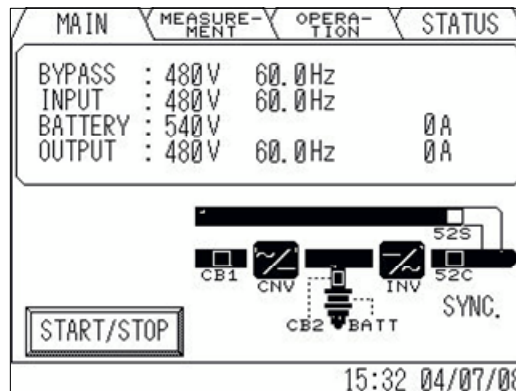
The Liquid Crystal Display (LCD) touch panel indicates power flow, measured values, operational guidance, data records and error messages. The LCD panel has a back-light which facilitates viewing in different ambient lighting conditions. The LCD will automatically clear and turn off, if the screen is not activated within 3 minute period. The LCD is turned back on when it is touched again. The ERROR indicator is cleared after 24 hours and can be reproduced by pressing any key on the panel.

### 2.3.1 MENU

#### A) MAIN MENU (FIGURE 2.2)

The LCD panel indicates power flow and measured values, while also operating the start/stop function. The LCD panel also allows the user to verify the status and operation of the UPS Module.

**FIGURE 2.2** Main screen



The following will be displayed when the START/STOP key on the MAIN MENU is pressed (Jump into **OPERATION MENU**) :

#### 1) Startup/Shutdown Guidance (FIGURE 2.3)

The display indicates the Startup and Shutdown guidance for the UPS system. If this operation is PIN protected, the user is required to enter the security PIN before the screen can be accessed.

When in remote mode, the message "REMOTE operating model" will appear on this Screen. The user cannot operate the start and stop functions without changing the setup from remote mode to local mode.

When bypass voltage is abnormal, the message "Bypass voltage abnormal" will appear.

**-Start:** When the bypass voltage is abnormal, the LCD asks the operator if an interrupted transfer is acceptable (Load may be lost).

**-Stop:** When the bypass voltage is abnormal, the user cannot transfer from inverter to bypass line.

- Press the **OPERATION** tab.

*FIGURE 2.3-a Startup/Shutdown guidance screen appears.*

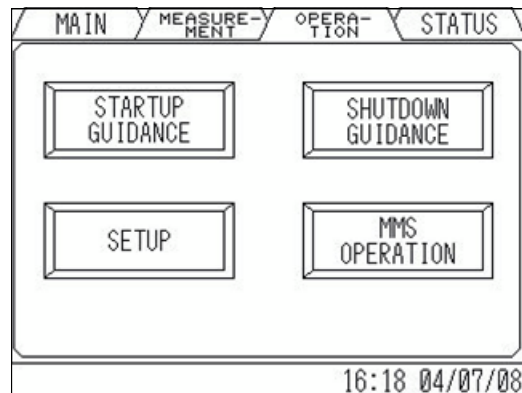
- - Press the **STARTUP GUIDANCE** button.

*FIGURE 2.3-b appears.*

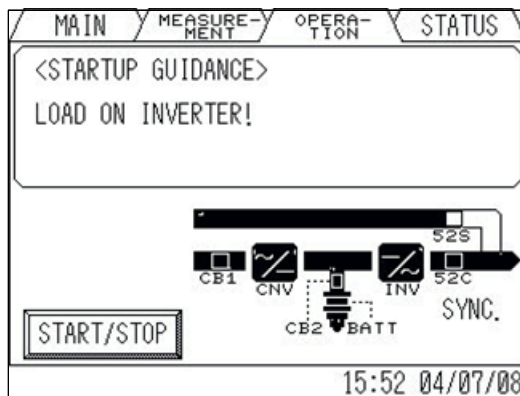
- - Press the **SHUTDOWN GUIDANCE** button.

*FIGURE 2.3-c appears.*

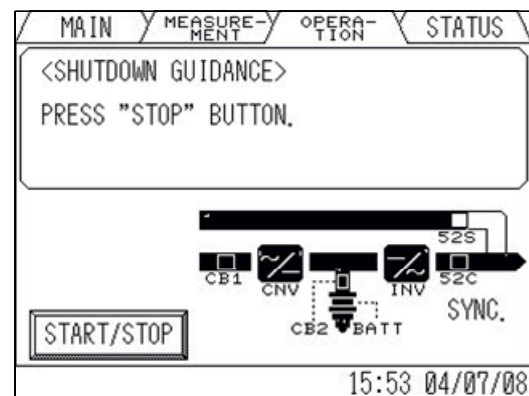
**FIGURE 2.3-a** Startup/Shutdown guidance



**FIGURE 2.3-b** Startup guidance



**FIGURE 2.3-c** Shutdown guidance



- - - Follow Startup/Shutdown guidance accordingly.

## B) MEASUREMENT MENU (FIGURE 2.4)

This screen shows details of measured values. Input and Output values are displayed. During Battery operation, Remaining battery power and Run time are also displayed.

### Measuring UPS Input Values

- Press the MEASUREMENT tab

*FIGURE 2.4-a appears displaying the UPS input parameters*

### Measuring UPS Output Values

- - Press the OUTPUT button

*FIGURE 2.4-b appears displaying the UPS output parameters (press the INPUT button to return to the input values)*

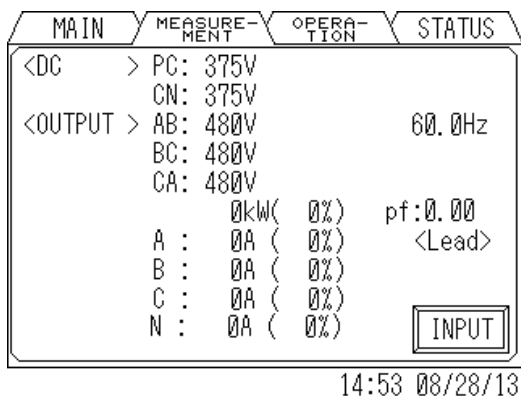
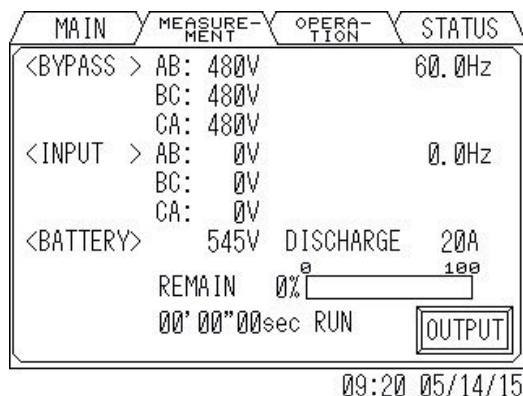
### Measuring battery values during Emergency mode operation

Battery information is available on the UPS OUTPUT screen, FIGURE 2.4-c. This screen displays the UPS output parameters and the following battery system data:

- Battery system voltage
- Battery system current
- Percent battery system power remaining (this is configured during commissioning)
- Elapsed battery runtime

**FIGURE 2.4-a** Input values

MAIN	MEASURE- MENT	OPERA- TION	STATUS
<BYPASS >	AB: 480V BC: 480V CA: 480V		60.0Hz
<INPUT >	AB: 480V BC: 480V CA: 480V		60.0Hz 0A
<BATTERY>	540V	DISCHARGE	0A
			[OUTPUT]
15:54 08/27/13			

**FIGURE 2.4-b** Output values

**FIGURE 2.4-c** Values in Battery operation

**C) OPERATION MENU (FIGURE 2.5)**

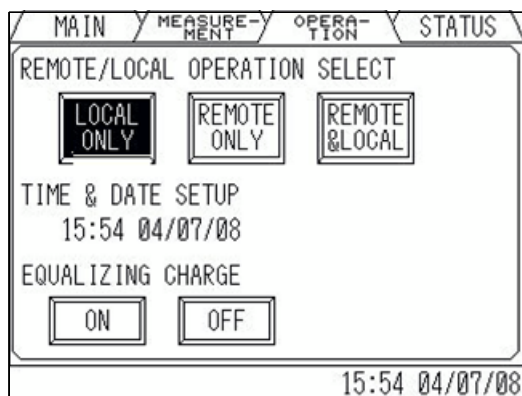
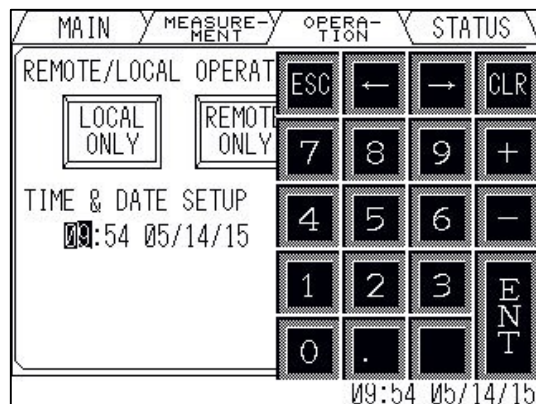
This screen prompts the user to select: (a) whether the start & stop operation will be performed by local or remote operation; (b) date & time adjustment; (c) battery equalizing charge. The battery equalizing charge operation key will appear when battery equalizing charge is set up (Setup is based on battery type).

- Press the **OPERATION** tab

*FIGURE 2.3-a appears displaying the OPERATION menu.*

- - Press the **SETUP** button

*FIGURE 2.5-a appears allowing the user to select the operation mode and allows setting of the time and date. If the battery equalizing charge option was configured during commissioning, an additional BATTERY EQUALIZING CHARGE key will appear.*

**FIGURE 2.5-a** Remote/Local operation select

**FIGURE 2.5-b** Date & Time adjustment


**D) STATUS MENU (FIGURE 2.6)**

This STATUS MENU displays two Touch icons in EVENT LOG and BATTERY LOG.

Pressing the EVENT LOG icon, up to 50 condition/operation records, including Enviro-mode ON/OFF, will be displayed. Press ▲ or ▼ button for page turning.

Pressing the BATTERY LOG icon, Number of battery operations and Summed battery operation time are displayed.

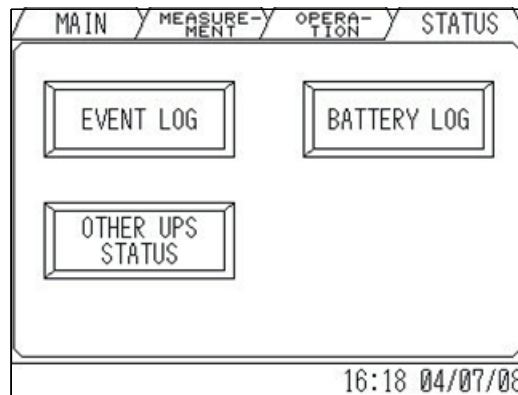
- Press the STATUS tab

FIGURE 2.6-a menu appears

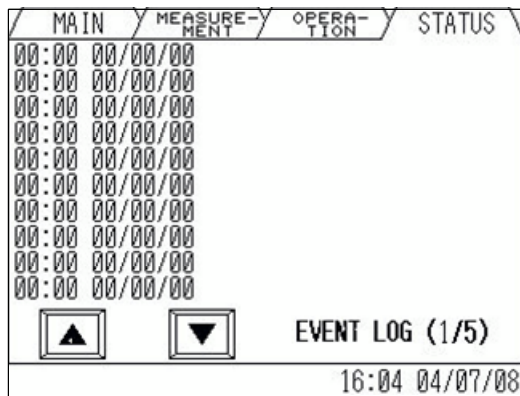
- Press the EVENT LOG button to review the UPS events, FIGURE 2.6-b.

- Press the BATTERY LOG button to check the battery operation, FIGURE 2.6-c.

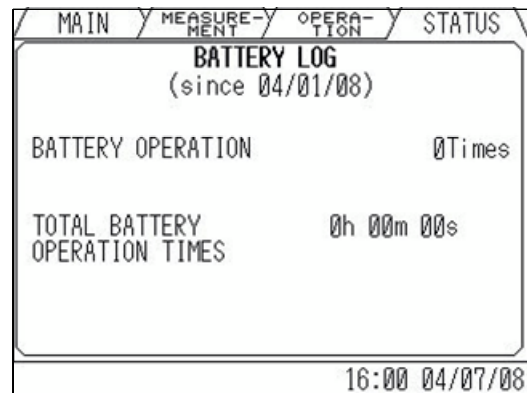
**FIGURE 2.6-a** Status menu



**FIGURE 2.6-b** Event log



**FIGURE 2.6-c** Battery log



### 2.3.2 INPUT POWER FAILURE (FIGURE 2.7)

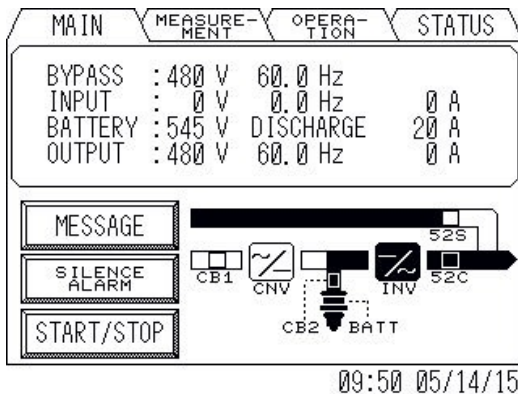
During an Input Power Failure, the UPS inverter will be powered by the UPS batteries. The following will be displayed on the main and measurement screen (Indication of battery operation and remaining battery life).

*Loss of UPS main input power automatically transfers to battery system operation and creates an alarm screen, FIGURE 2.7-a.*

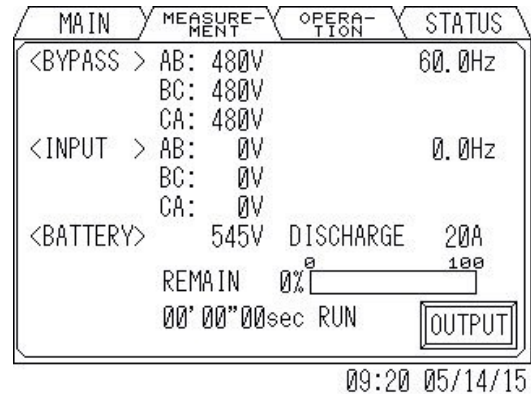
- The alarm is silenced by pressing the SILENCE ALARM button.
- UPS parameters can be measured by pressing the MEASUREMENT tab, FIGURE 2.7-b.

*The alarm source is displayed by pressing the MESSAGE button. The UPS stores multiple alarms in a last-in/first-out configuration, in that; the last alarm is the first message in the series.*

**FIGURE 2.7-a** Main screen  
(Battery operation)



**FIGURE 2.7-b** Measurement screen  
(Battery operation)



The LCD will display a battery low voltage message when the battery capacity is near depletion. The End of Battery Discharge announcement is displayed when the battery end voltage is reached. At this time, the inverter will perform an electronic shutdown to prevent battery loss of life typical from extreme deep discharge conditions. When the input power is restored, the inverter will automatically restart to power the load, and the batteries will be simultaneously recharged. The End of Battery announcement is shown at the bottom of the screen.

### 2.3.3 FAULT INDICATION (FIGURE 2.8)

“MESSAGE” and “SILENCE ALARM” icons will appear on the main menu when UPS failure condition has occurred.

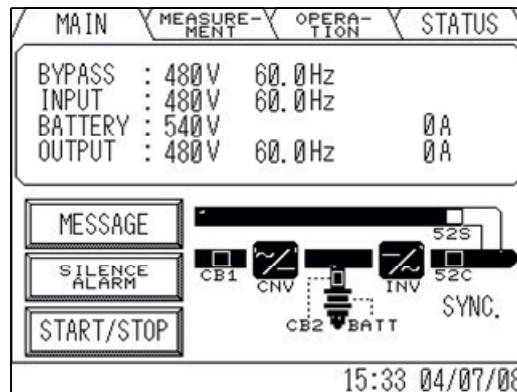
*The UPS monitors its status and provides a fault indication when it detects an abnormal condition, FIGURE 2.9.*

- The alarm is silenced by pressing the SILENCE ALARM button.

- UPS parameters can be measured by pressing the MEASUREMENT tab, FIGURE 2.7-b.

*The alarm source is displayed by pressing the MESSAGE button. The UPS stores multiple alarms in a last-in/first-out configuration, in that; the last alarm is the first message in the series.*

**FIGURE 2.8** Main screen (Fault indication)

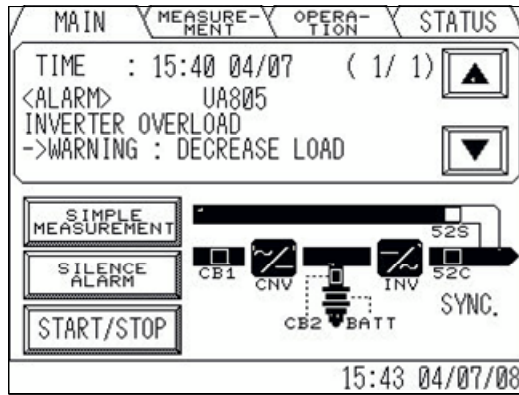


The following will be displayed when the MESSAGE icon on the main menu is pressed.

#### 1) MESSAGE (FIGURE 2.9)

The display shows a fault code, the description of the fault and a guidance of what action is to be taken by the user. A maximum of 10 faults is displayed at one time. If an input power failure occurs during a fault condition, the fault indication and input power failure announcement are alternatively displayed at 5 second intervals.

FIGURE 2.9 Message screen



2) SILENCE ALARM

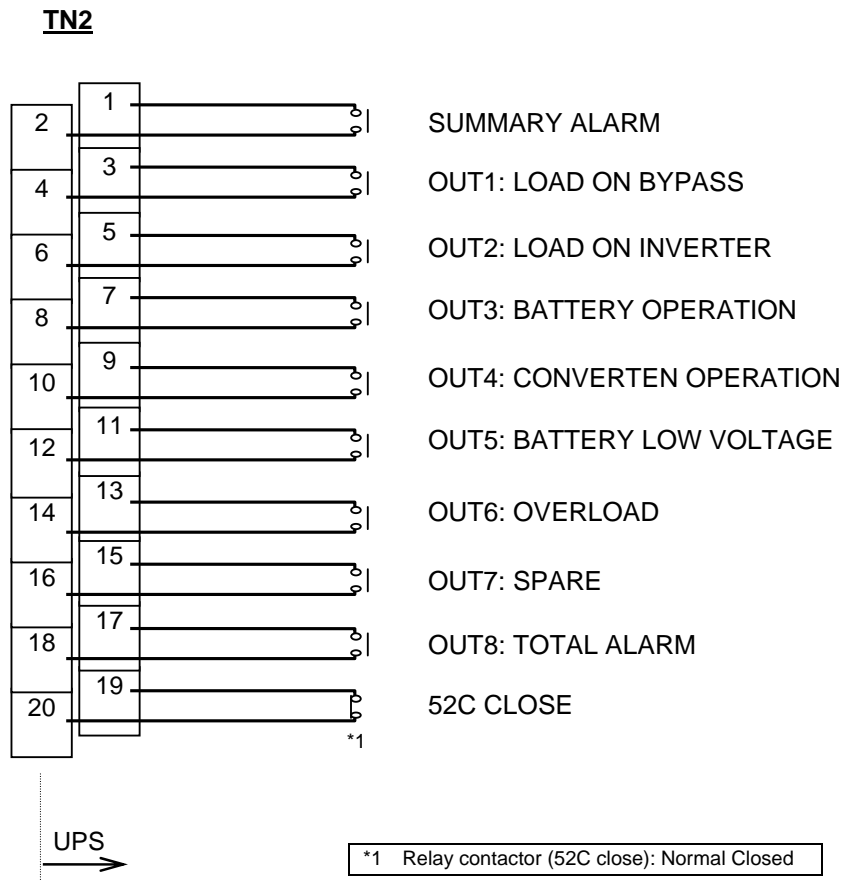
This icon will appear when a failure occurs. The audible alarm (announcing the failure) can be silenced by pressing this icon.



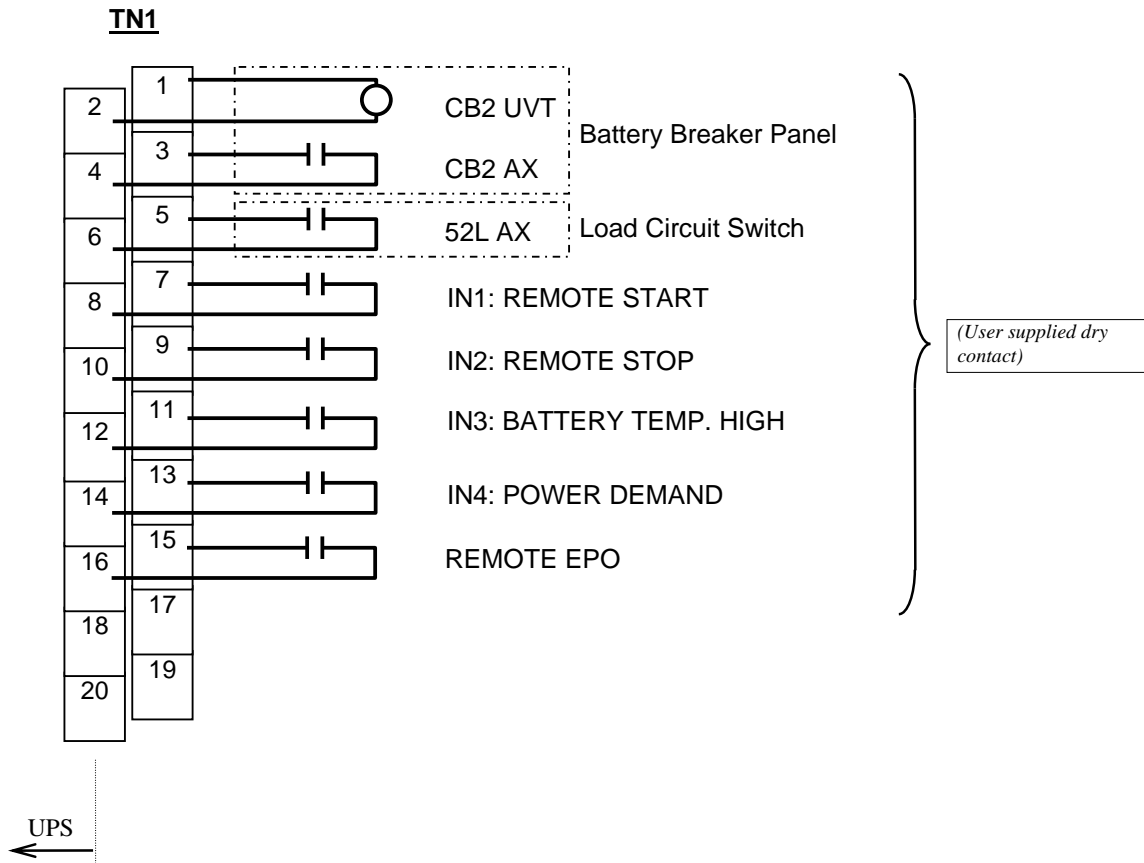
## 2.4 EXTERNAL SIGNAL TERMINAL BLOCK

The UPS is equipped with a series of input/output terminals for external annunciation of alarms and for remote access of certain UPS functions. The layout of terminals is shown in Figure 2.10 with a functional description of the input/output port presented. OUT1 to OUT8 are user programmable, but are factory default set being also shown in Figure 2.10. Adding same external I/F PCB "IOAU-09", doubling signal outputs is applicable for OUT1 to OUT8.

**FIGURE 2.10-a** External Signal Terminal Block (NEC Class2)

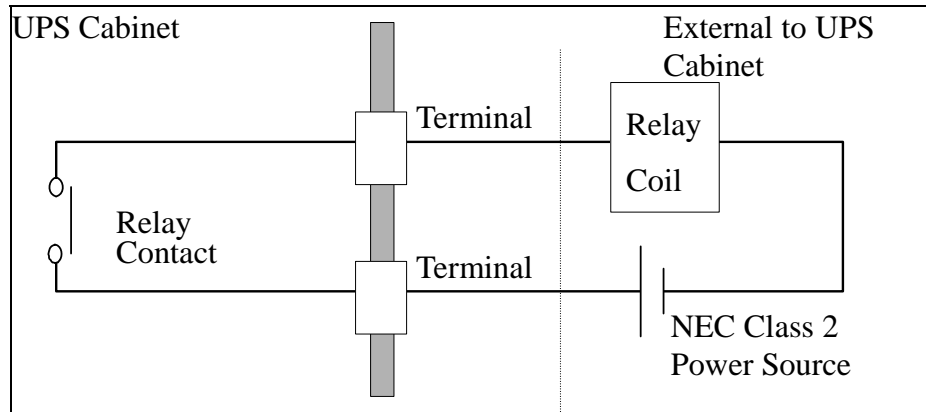


**FIGURE 2.10-b** External Signal Terminal Block (NEC Class2)



**A) Output Contacts (for external alarm annunciation)**

Output contacts consist of form “A” dry type contacts. Rated capacity of all output contacts is NEC Class2 (30Vdc/1Adc). All dry contacts should be operated at their rated values or lower. Figure 2.11 illustrates a typical installation. The external relay can also be a lamp, LED, computer, etc.

**FIGURE 2.11 Control Wiring for External Contacts**

**Details of output alarm contacts : TN2**
**Terminals 1 to 2 "Summary Alarm" contact**

Activated when a major fault has occurred with the system.

**Terminals 3 to 4 "Load on Bypass" contact (OUT1)**

Activated when the power is supplied from the static bypass input.

**Terminals 5 to 6 "Load on Inverter" contact (OUT2)**

Activated when the power is supplied by the inverter.

**Terminals 7 to 8 "Battery Operation" contact (OUT3)**

Activated when the battery is operating following an AC power failure.

**Terminals 9 to 10 "Converter Operation" contact (OUT4)**

Activated when the converter is operating.

**Terminals 11 to 12 "Battery Low Voltage" contact (OUT5)**

Activated when the battery voltage drops below discharge end voltage level during inverter operation (i.e. During AC fail condition).

**Terminals 13 to 14 "Overload" contact (OUT6)**

Activated when an overload has occurred to the system.

**Terminals 15 to 16 "Spare" contact (OUT7)**
**Terminals 17 to 18 "Total Alarm" contact (OUT8)**

Activated during major fault, minor fault and alarm events.

**Terminals 19 to 20 "52C Close" contact (OUT9)**

Activated when the inverter output contactor 52C has closed.

→  
*User supplied*



**NOTE:** *The UPS is equipped with a selectable output contact feature. The above alarms are the default settings. Contact MITSUBISHI ELECTRIC POWER PRODUCTS, INC for setup information.*

### B) Input Contacts (for remote access of UPS)

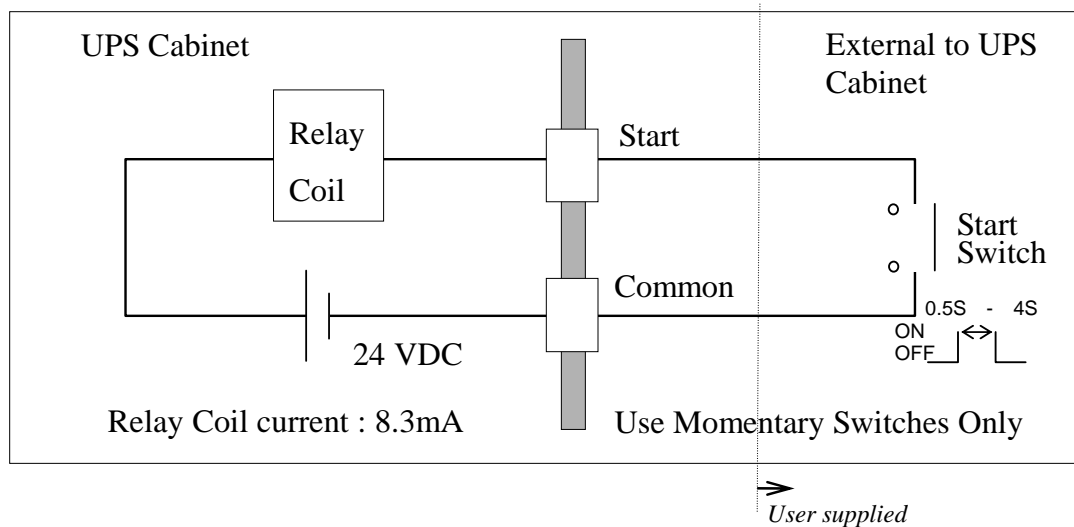
External contacts are provided by the user of the UPS system. Terminal voltage at the UPS is 24Vdc. Provide external dry contact accordingly.



**CAUTION:** *Do not apply voltages to remote access input terminals. Damage to UPS may result.*

Refer to Figure 2.12 for a typical wiring configuration. Although this figure applies to the remote start/stop terminals, the same wiring arrangement is used for emergency stop; power demand; and battery temperature high.

**FIGURE 2.12** Remote "Start" Contact Connections



**Details of input contacts for remote access : TN1****Terminals 7 to 8 Remote "Inverter Start" input terminal (IN1)**

Used to start inverter from a remote location. UPS must be programmed for remote operation. Refer to Operations Menu for procedure.

**Terminals 9 to 10 Remote "Inverter Stop" input terminal (IN2)**

Used to stop inverter from a remote location. UPS must be programmed for remote operation. Refer to Operations Menu for procedure.

**Terminals 11 to 12 "Battery Temp. High" contact input (IN3)**

Input fed by a thermocouple that monitors battery temperature. The converter float voltage level is reduced for battery over-temperature conditions. External thermocouple is user supplied

**Terminals 13 to 14 "Power Demand" Command contact input (IN4)**

This contact is used to control the input power. Power demand is turned ON when the contact is closed, and power demand is turned OFF when the contact is open.

**Terminals 15 to 16 "Remote EPO" contact input**

Used to perform a remote UPS Emergency Power Off (EPO).

*The load will be dropped.*



**NOTE:** *The UPS is equipped with a selectable input contact item.*

*The above items are the default settings. MITSUBISHI ELECTRIC POWER PRODUCTS, INC for setup information.*

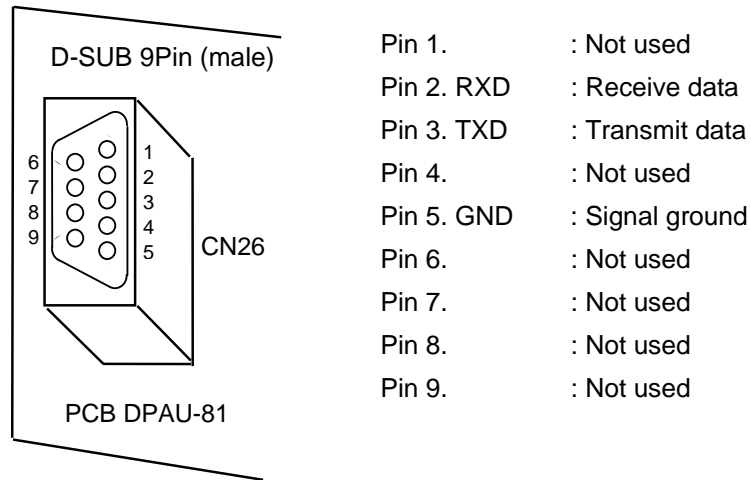


**CAUTION :** *In all cases, a switch having a protective cover is recommended in order to reduce the possibility of accidental operation.*

## 2.5 EXTERNAL COMMUNICATION CONNECTOR

This is an RS232C port for “DiamondLink”\* monitoring software.  
The layout of connector is shown in Figure 2.13.

**FIGURE 2.13** External communication connector (NEC Class2)



\* Consult MITSUBISHI ELECTRIC POWER PRODUCTS, INC for details on “DiamondLink” monitoring software and its capabilities.

### 3.0 INSTALLATION AND OPERATION

#### 3.1 TRANSPORTATION AND INSTALLATION

**TABLE 3.1** How to transport and install the system

Transportation	Installation
Transport unit with forklift. Carry with overhead crane using 4xM12 screw-eyebolts. (Not provided)	Using the pre-drilled four holes in the UPS channel base, anchor the unit using appropriate hardware. (Not provided)



**CAUTION :** *Do not transport in a horizontal position. Cabinets must be maintained upright within +/- 15° of the vertical during handling.*

#### 3.2 INSTALLATION PROCEDURE

**A) Note the load tolerance of the floor**

Refer to Table 3.2 for list of UPS weights.

**TABLE 3.2** List of UPS weights

UPS Capacity (kVA)	80	100	150	160	225
Weight (lb.)	801	801	893	893	1119

**B) Minimum clearance required for ventilation**

Right side ..... 25 mm (1 inch) (not required when sidecars are used)

Left side ..... 25 mm (1 inch) (not required when sidecars are used)

Back side ..... 0.0 mm (0 inch)

Top side ..... 500 mm (20 inches) (for air flow)

**C) Space requirement for routine maintenance**

Allow for the following space at the time of installation.

Front ..... 1000 mm (40 inches)

Sides ..... 0.0 mm (0 inch)

Back side ..... 0.0 mm (0 inch)

Top side ..... 500 mm (20 inches)

#### D) External Battery Supply

Please refer to the following when installing and maintaining batteries:



1. The customer shall refer to the battery manufacturer's installation manual for battery installation and maintenance instructions.
2. The maximum permitted fault current from the remote battery supply, and the DC voltage rating of the battery supply over-current protective device are shown in Table 3.3.

**TABLE 3.3** Maximum Permitted DC Fault Current

UPS Capacity (kVA)	DC Voltage Rating (V)	Maximum Fault Current Permitted (A)
80	480	25,000
100	480	25,000
150	480	25,000
160	480	25,000
225	480	25,000

### 3.3 PROCEDURE FOR CABLE CONNECTIONS

1. Confirm the capacity of the UPS being installed. Identify the input/output power terminal blocks as shown in the appropriate Figures 3.1 through 3.3.
2. Connect the internal control wire and power wire.
  - (1) Control wire Inter-connect
    1. CB2 UVT to terminal TN1-1, 2 of external I/F PCB IOAU-09.
    2. CB2 ON Auxiliary to terminal TN1- 3, 4 of external I/F PCB IOAU-09.
  - (2) Power wire (AC input, Bypass input, AC output) Inter-connect
    - a.) From user's distribution panel
      1. X1 (A-phase) to A bus bar in UPS
      2. X2 (B-phase) to B bus bar in UPS
      3. X3 (C-phase) to C bus bar in UPS
    - b.) DC Input to UPS
      1. Positive cable to BP bus bar in UPS
      2. Negative cable to BN bus bar in UPS





**CAUTION :** *After the completion of the input power cables connection:*  
*With a phase rotation meter, check that the phase rotation of the AC Input power terminals A, B and C as well as the Bypass Input power terminals A40, B40 and C40 are correct. The proper phase rotation is clockwise A → B → C.*

3. Connect the grounding conductor from the input service entrance to the UPS Ground Bar (E). Ground the UPS in accordance with local, state, and federal procedures using the UPS ground bar (E). Verify the UPS has a single-point ground.
4. Two (2) sources feeding the UPS:
  - (1) Connect the AC input power cables from the input service entrance to the AC input power terminals, identified as A, B, C in Figures 3.1 to 3.3. Input cables must be sized for an ampere rating larger than the maximum input drawn by the converter. (Refer to equipment nameplate for current ratings.) Confirm that an external bypass input circuit breaker (MCCB) is installed (refer to WARNING 4, page 1-4). Connect the bypass input power cables from the input service entrance to the bypass input power terminals, identified as A40, B40 and C40 in Figures 3.1 to 3.3. Bypass input cables must be sized for an ampere rating larger than the maximum output current capacity of the UPS. Refer to Table 3.4 for recommended cable sizes.
  - (2) Connect the external signal terminal block as desired. Refer to section 2.4 and Figure 2.10 for functional description. 2mm<sup>2</sup>, or less, shielded conductor is recommended.
5. One (1) source feeding the UPS:
  - (1) Confirm that an external input circuit breaker sized to protect both the AC input and the bypass line is installed. (Refer to UPS nameplate for current ratings.) Connect the bypass input power cables from the customer's source to the bypass input power terminals, identified as A40, B40 and C40 in Figures 3.1 to 3.3. Input cables must be sized in accordance with local, state, or federal codes.. Refer to Table 3.4 for recommended cable sizes.
  - (2) Using adequately sized conductors and referring to the appropriate figure identified in Figures 3.1 to 3.3, connect jumper bypass terminals A40, B40, C40 to AC input power terminals A, B, C as identified in Figures 3.1 to 3.3.

- (3) Connect the external signal terminal block as desired. Refer to section 2.4 and Figure 2.10 for functional description. 2mm<sup>2</sup> (12 – 16 AWG), shielded conductor is recommended.

**CAUTION :** 1. *Confirm that all UPS internal contactors (breakers) "CB1", "CB2", and "CB3" are open before energizing UPS.*



2. *UPS power terminals are supplied with stud type fittings.*

*It is recommended that compression lugs be used to fasten all input/output power cables.*

6. In case of both power wirings and low voltage control wirings (for control) come from the bottom of UPS, confirm the two conduits on the bottom (refer to Figure 3.4) and be sure to keep them separated. The bigger conduit is for high voltage wirings, and the smaller one is for control wirings (from / to IOAU-09). The control wirings can enter the UPS either through the bottom or top, figure 3.4 or 3.5 respectively. In either case, the control wirings shall be in their own conduit.
7. Procedure for Cable Connections for Parallel Operation System
- (1) Confirm the number of units to be connected in parallel. Identify the input/output power terminal blocks and control wire connections for parallel operation systems as shown in the appropriate Figures 3.6 and 3.7.
- (2) Connect the external control wire and power wire.
- a.) Control wire connection
- Parallel configuration wiring (Refer to Figure 3.6 and 3.7.)
- 52L control signal from Critical Load Cabinet (CLC) to UPS-n IOAU-09 (TN1– 5 , 6).
  - Parallel control signal for CN94 as shown in Fig. 3.7.
  - Parallel control signal for CN96 and CN95 as shown in Fig. 3.7.
- b.) Power wire connection
- From UPS AC Output Terminals to Critical Load Cabinet (CLC) (Refer to Figure 3.6 and 3.7.)

**TABLE 3.4** Recommended Cable Sizes\*<sup>1, 2, 3</sup>

kVA Capacity	Input Voltage	Output Voltage	Input Side		Output Side		Bypass Side		DC Input Side	
			Cable Size	Torque in. lbs	Cable Size*	Torque in. lbs	Cable Size	Torque in. lbs	Cable Size	Torque in. lbs
80kVA	480V	480V	1/0 AWG	200 - 269 in. lbs	1/0 AWG	200 - 269 in. lbs	1/0 AWG	200 - 269 in. lbs	4/0 AWG	200 - 269 in. lbs
100kVA	480V	480V	2/0 AWG	200 - 269 in. lbs	2/0 AWG	200 - 269 in. lbs	2/0 AWG	200 - 269 in. lbs	1/0 AWG by 2	200 - 269 in. lbs
150kVA	480V	480V	1/0 AWG by 2	200 - 269 in. lbs	1/0 AWG by 2	200 - 269 in. lbs	1/0 AWG by 2	200 - 269 in. lbs	4/0 AWG by 2	200 - 269 in. lbs
160kVA	480V	480V	1/0 AWG by 2	200 - 269 in. lbs	1/0 AWG by 2	200 - 269 in. lbs	1/0 AWG by 2	200 - 269 in. lbs	4/0 AWG by 2	200 - 269 in. lbs
225kVA	480V	480V	3/0 AWG by 2	200 - 269 in. lbs	3/0 AWG by 2	200 - 269 in. lbs	3/0 AWG by 2	200 - 269 in. lbs	350MCM by 2	200 - 269 in. lbs

\*1 - The cables must be selected to be equal to the sizes listed in the table.

\*2 - Voltage drop across power cables not to exceed 2% of nominal source voltage.

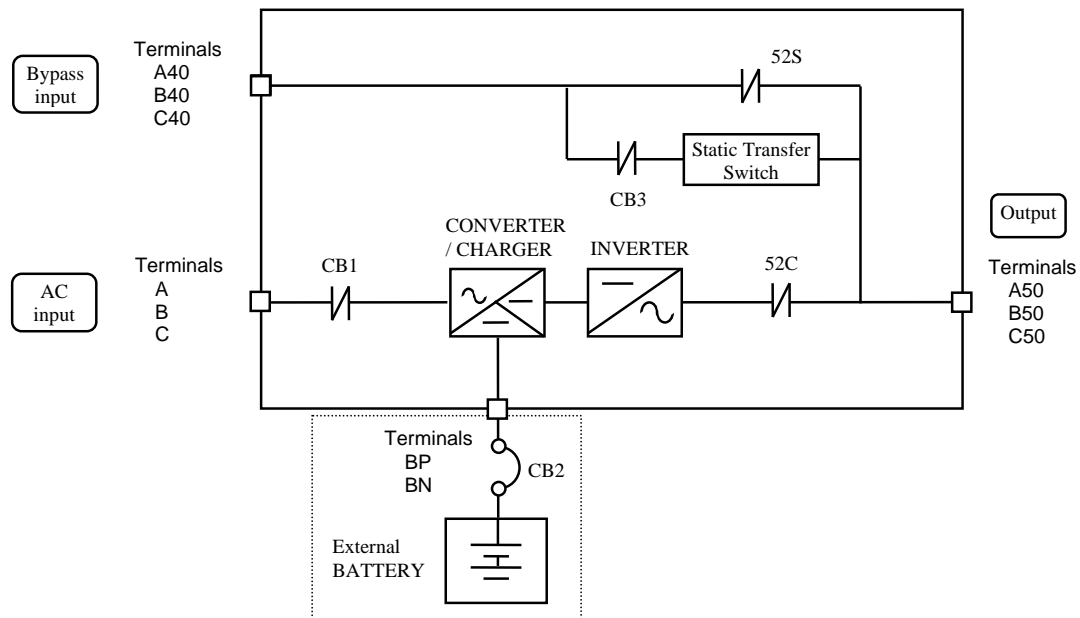
\*3 - Allowable ampere-capacities based on 75 degree C. insulation at ambient temperature of 40 degree C.

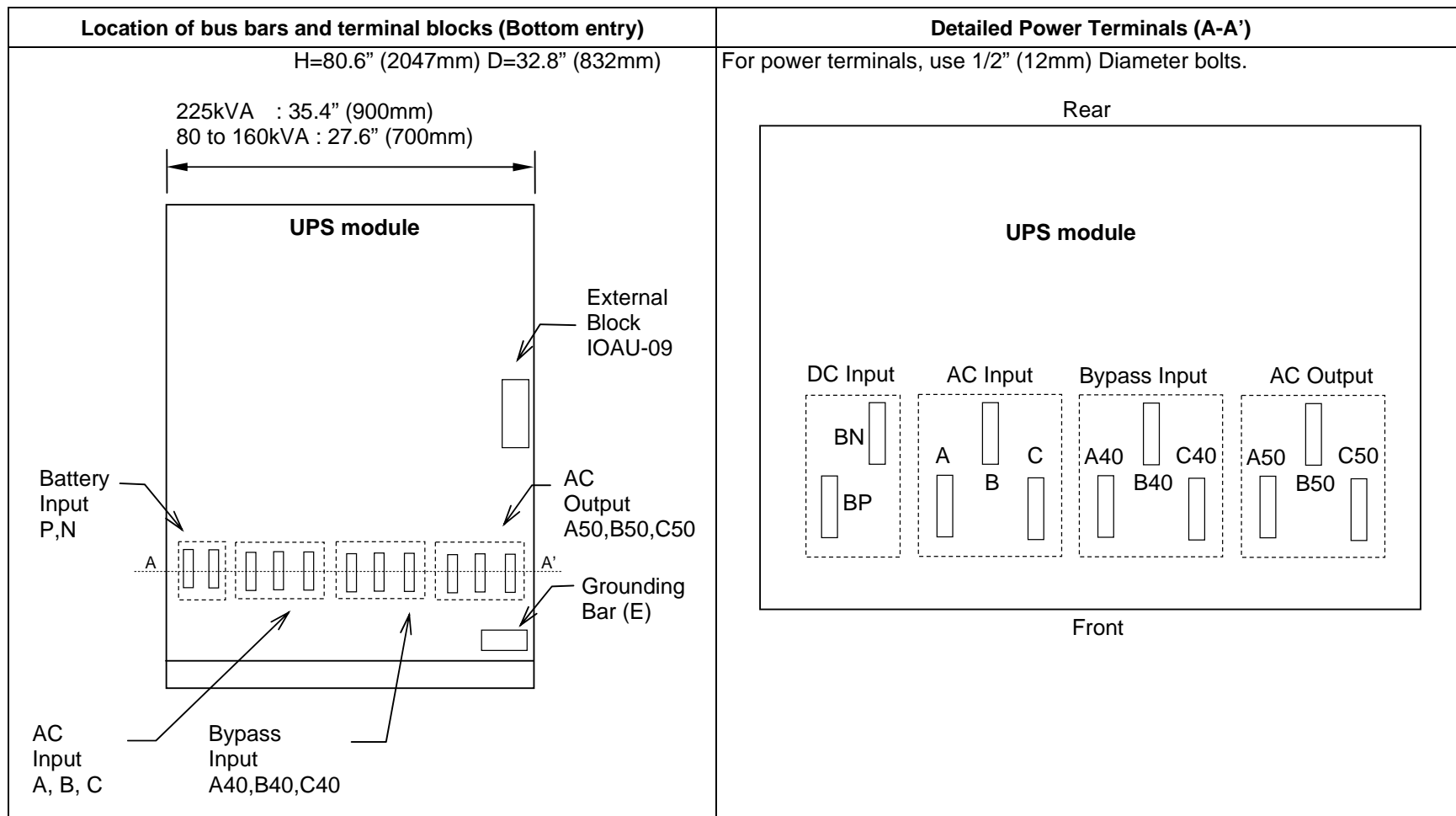
**Note: Copper conductors assumed.**

**TABLE 3.5** Crimp Type Compression Lug

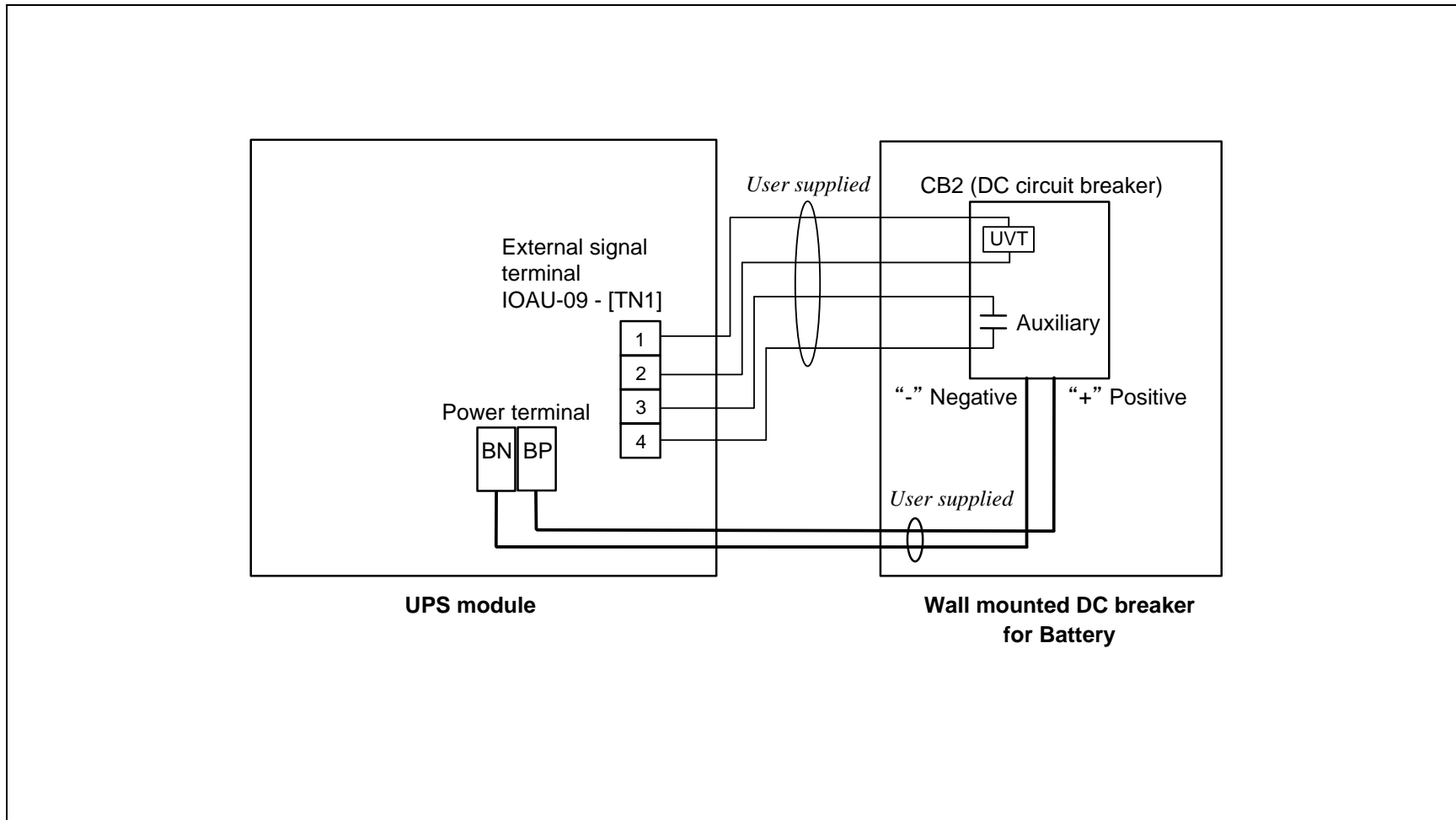
WIRE SIZE (CODE)	WIRE STRAND CLASS	RECOMMENDATION		CRIMP TOOL REQUIRED BURNDY TYPE Y35 OR Y46	
		VENDOR	CAT. NO.	COLOR KEY	DIE INDEX
1	B	BURNDY	YA1C	GREEN	11 / 375
	I	ILSCO	CRA-1L	GREEN	11 / 375
	I	BURNDY	YA25-LB	---	1019
1/0	B	BURNDY	YA25	PINK	12 / 348
	I	ILSCO	CRA-1/OL	PINK	12 / 348
	I	BURNDY	YA25-LB	---	1020
2/0	B	BURNDY	YA26	BLACK	13
	I	ILSCO	CRA-2/OL	BLACK	13
	I	BURNDY	YA27-LB	---	1021
3/0	B	BURNDY	YA27	ORANGE	14 / 101
	I	ILSCO	CRB-3/OL	ORANGE	14 / 101
	I	BURNDY	YA28-LB	---	1022
4/0	B	BURNDY	YA28	PURPLE	15
	I	ILSCO	CRB-4/OL	PURPLE	15
	I	BURNDY	YA29-LB	---	1023
250 MCM	B	BURNDY	YA29	YELLOW	16
	I	ILSCO	CRA-250L	YELLOW	16
	I	BURNDY	YA30-LB	---	1024
300 MCM	B	BURNDY	YA30	WHITE	17 / 298
	I	ILSCO	CRA-300L	WHITE	17 / 298
	I	BURNDY	YA32-LB	---	1026
350 MCM	B	BURNDY	YA31	RED	18 / 324
	I	ILSCO	CRA-350L	RED	18 / 324
	I	BURNDY	YA34-LB	---	1027
400 MCM	B	BURNDY	YA32	BLUE	19 / 470
	I	ILSCO	CRA-400L	BLUE	19 / 470
	I	BURNDY	YA36-LB	---	1027
500 MCM	B	BURNDY	YA34	BROWN	20 / 299
	I	ILSCO	CRA-500L	BROWN	20 / 299
	I	BURNDY	YA38-LB	---	1029

**NOTE:** When using crimp type lugs, the lugs should be crimped to the specifications given in the manufacturer's instructions for both crimp tool and lug.

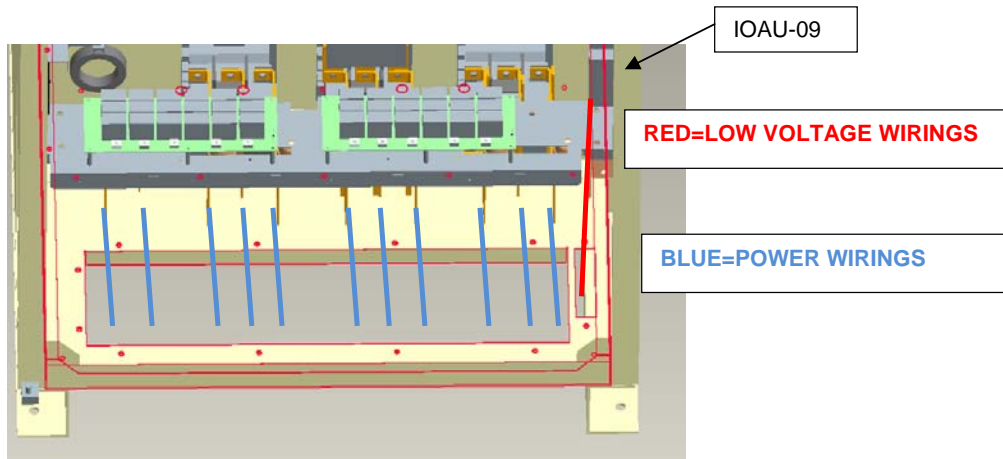
**FIGURE 3.1** UPS Terminal Designation


**FIGURE 3.2** Diagram of input/output bus bars and terminal blocks


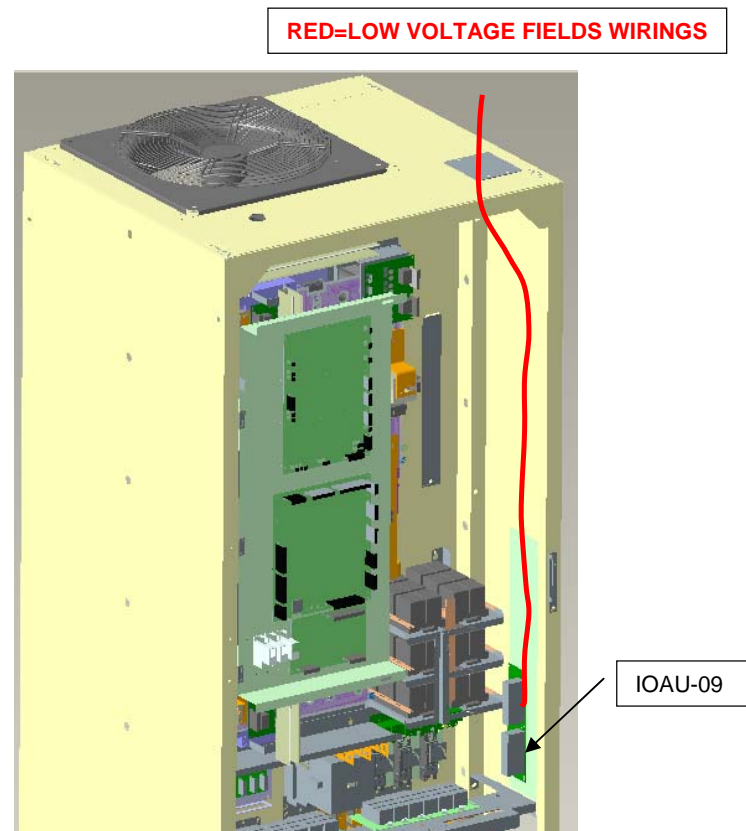
**FIGURE 3.3** Diagram of Power Wire & Control Wire Inter-Connect between UPS and Battery

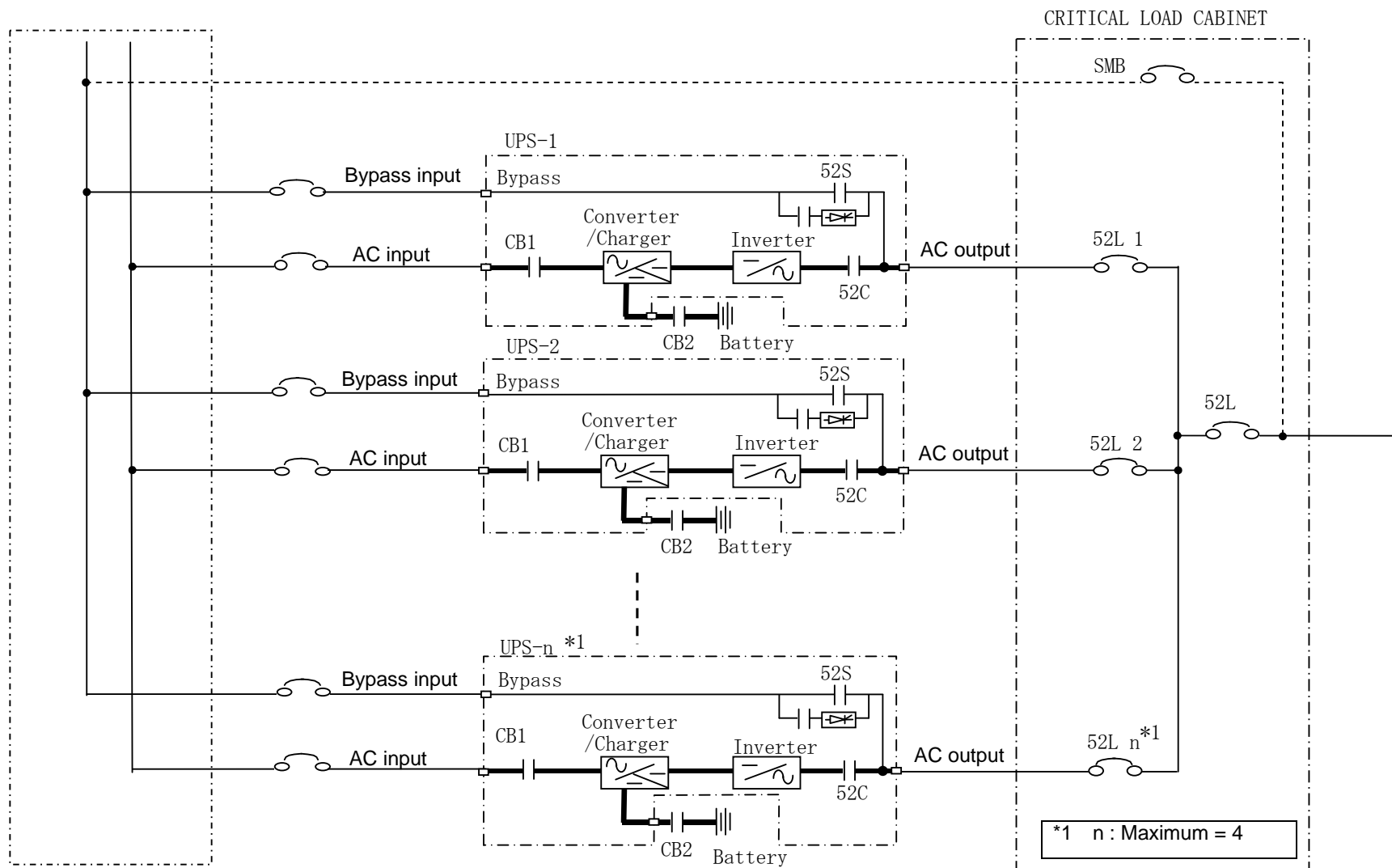


**FIGURE 3.4** Cable Entry on Bottom (Example of 225kVA)

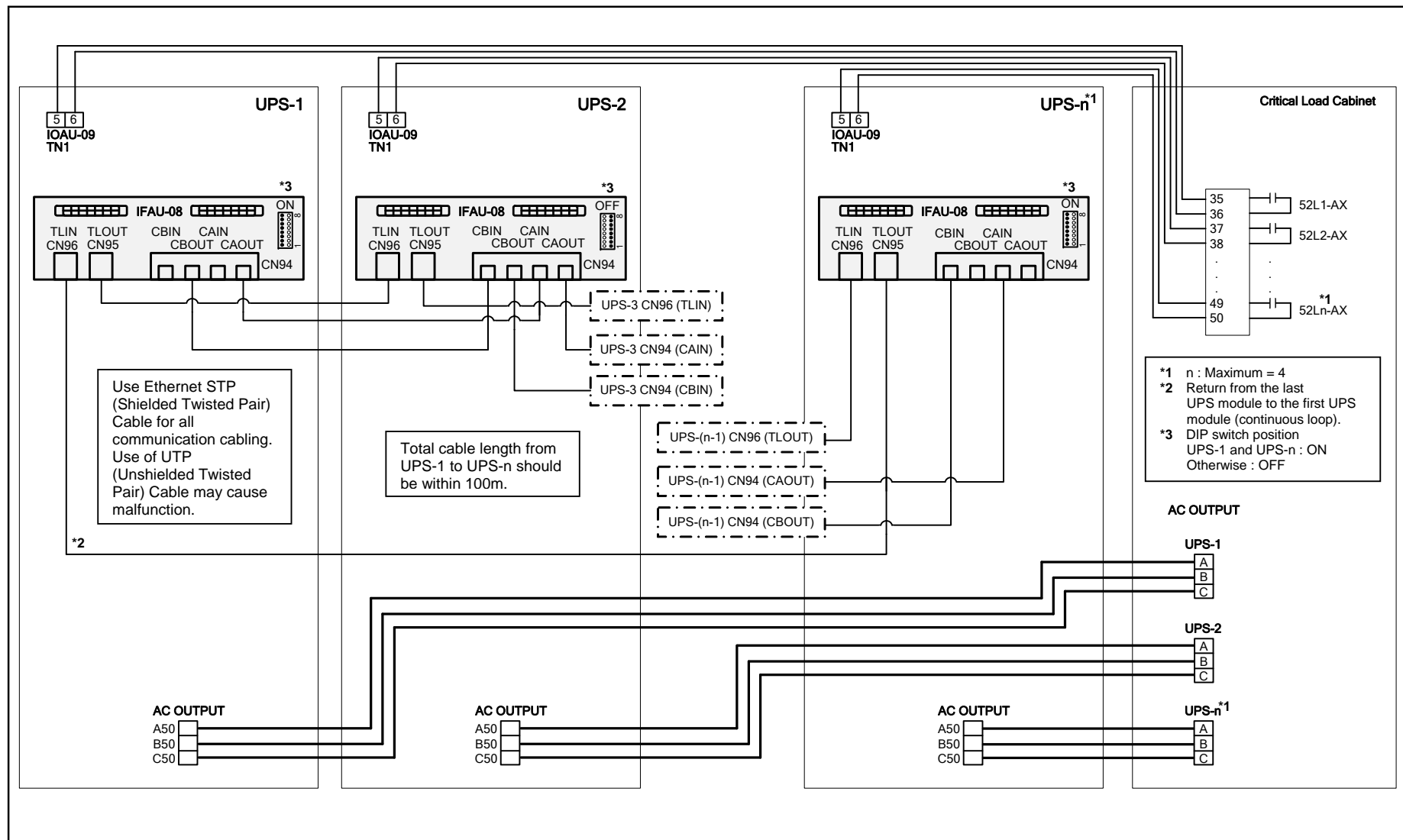


**FIGURE 3.5** Cable Entry on Top (Example of 225kVA)



**FIGURE 3.6** Diagram of Power Wire Connect ( Parallel Operation system connection )




**FIGURE 3.7** Diagram of Power Wire & Control Wire Connect ( Parallel Operation system connection )


### 3.4 OPERATING PROCEDURES

For Parallel Operation system, refer to section “D) MMS Start-up Procedure”.  
(Parallel Operation system is herein after MMS [Multi Module System])

For Enviro-Mode Operation system, refer to section “E) Enviro-mode Start-up Procedure”.

#### A) Start-up Procedure



**CAUTION :** *Before the UPS startup, the internal Bypass line starts to supply the unconditioned bypass input power to the critical load if the External input (or Bypass) Circuit Breaker is closed. Be extremely careful with closing the External input (or Bypass) Circuit Breaker.*

- a.) Verify that the External Bypass Input Circuit Breaker for each unit is closed.  
(user supplied)
- b.) Verify that Battery Disconnect Circuit Breaker (CB2) is opened or in tripping position.
- c.) If a dual source is feeding the UPS, close the External AC Input Circuit Breaker manually (user supplied).
- d.) The LCD panel boots up automatically, and the screen will show that the Load is powered by bypass line.
- e.) On the LCD panel, select “OPERATION” tab, and then press the “STARTUP GUIDANCE” button to proceed UPS start-up. (Refer to Figure 2.3)
- f.) Follow the “STARTUP GUIDANCE” accordingly until the completion of the inverter startup.



**Note:** *When "REMOTE OPERATION MODE" is displayed on the LCD panel, the inverter start operation can only be performed remotely. If local inverter start operation is required (at the UPS), select "LOCAL ONLY" or "REMOTE & LOCAL" in the OPERATION MENU.*

## B) Shut-down Procedure

If a total UPS shutdown is required, verify that the critical load is OFF or supplied from a separate source isolated from the UPS output.

- a.) Press the "START/STOP" icon from the Main Menu or the Operation Menu on the LCD.
- b.) On the LCD panel, press "START/STOP" icon, and then select "SHUTDOWN GUIDANCE" icon. (Refer to Figure 2.3)
- c.) Follow the "SHUTDOWN GUIDANCE" accordingly until Inverter stops. However UPS will simultaneously transfer the power feeding from the Inverter supply to the Bypass line supply.
- d.) In general, only the Inverter will be stopped and the Converter will remain energized to charge the batteries.



**Note:** When "REMOTE OPERATION MODE" is displayed on the LCD panel, the inverter start operation can only be performed remotely. If local inverter stop operation is required (at the UPS), select "LOCAL ONLY" or "REMOTE & LOCAL" in the OPERATION MENU.

- e.) If stopping both the Inverter and Converter is required, open the Battery Disconnect circuit breaker (CB2) manually in accordance with guidance.

**WARNING** : Verify the load is OFF or supplied from a separate source isolated from the UPS output if the next step is to be performed .



**NOTE** : Power to the critical load is supplied through the bypass line. Power to the critical load will be lost after execution of the next step. The load will drop, if not supplied from a separate source isolated from the UPS output.

- f.) If a dual source is feeding the UPS, open the External AC Input Circuit Breaker (user supplied) manually.
- g.) If turning off all power to the critical load is desired, open the External Bypass Input Circuit Breaker (user supplied) manually.



**CAUTION :** *In bypass mode, all UPS power terminals are still live. Lethal voltages are present. De-energize all external sources of AC and DC power. Before removing the covers, wait 5 minutes after de-energizing. Check no-voltage before handling UPS. Be careful for the devices even when the UPS has been de-energized, still internal devices may be hot.*

### C) Bypass Operation Procedure

#### \*\* Transfer from Inverter to Bypass

1. Check for "SYNC" on the LCD.
2. Press the "START/STOP" icon on the LCD.
3. Follow the "SHUTDOWN GUIDANCE" and Press the "STOP" icon on the LCD.

#### \*\* Transfer from bypass to inverter.

#### **UPS**

1. Press the "START/STOP" icon on the LCD.
2. Follow the "STARTUP GUIDANCE" and Press the "START" icon on the LCD..



**Note:** *When "REMOTE OPERATION MODE" is displayed on the LCD panel, the inverter start operation can only be performed remotely. If local inverter start or stop operation is required (at the UPS), select "LOCAL ONLY" or "REMOTE & LOCAL" in the OPERATION MENU.*

## D) MMS Start-up Procedure

### **External Circuit Check**

1. Verify that Critical Load Cabinet (CLC) Circuit Breaker SMB is closed.
2. Verify that CLC System Output Circuit Breaker 52L is open.
3. Verify that CLC UPS Circuit Breakers 52L1, 52L2...and 52Ln are closed.

### **Start-up from UPS-1 to UPS-n**

1. Start-up each UPS in accordance with "A) Start-up Procedure". Each UPS will start Inverter Operation in synchronization with the bypass input.

### **Transfer from Maintenance Bypass to MMS Bypass Operation**

1. Closed the CLC System Output Circuit Breaker 52L.
2. Open the CLC Circuit Breaker SMB.

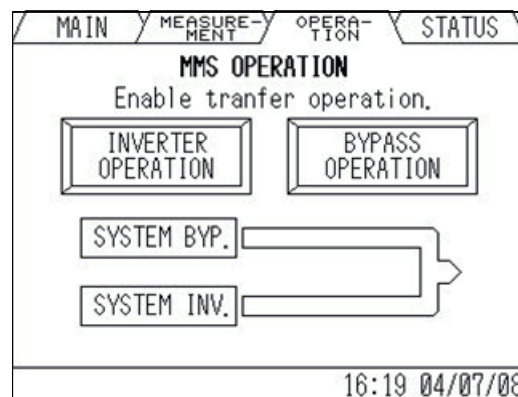


**Note:** When "REMOTE OPERATION MODE" is displayed on the LCD panel, the inverter start operation can only be performed remotely. If local inverter start operation is required (at the UPS), select "LOCAL ONLY" or "REMOTE & LOCAL" in the OPERATION MENU.

### **Transfer from UPS MMS Bypass Operation To UPS MMS Inverter Operation**

1. Transfer MMS Bypass Operation to MMS Inverter Operation from Operation Menu on any UPS LCD as shown in Fig. 3.8.

**FIGURE 3.8** LCD Screen (MMS Operation)



### **Transfer from UPS MMS Inverter Operation To UPS MMS Bypass Operation**

1. Transfer MMS Inverter Operation to MMS Bypass Operation from Operation Menu on any UPS LCD as shown in Fig. 3.8.

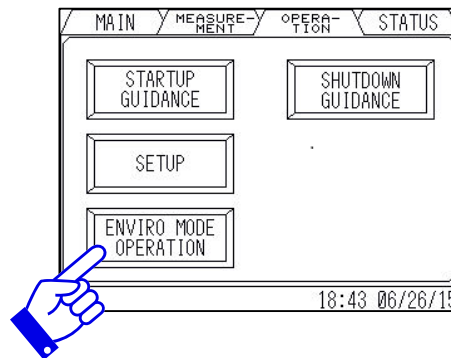
**E) Enviro-mode Start-up Procedure (Inverter → Enviro-mode)**


**Note: Single Module Operation only**

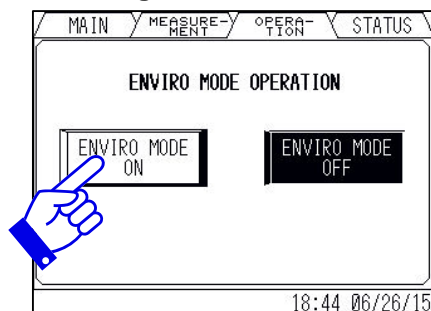
Contact Mitsubishi Electric Power Products, Inc. or its authorized service representatives to install and enable the Enviro-mode.

- (1) Verify that the inverter is running.  
Press the “OPERATION” key in MAIN menu on the LCD. (**Figure 2.2**)
- (2) Press the “ENVIRO MODE OPERATION” key in OPERATION menu on the LCD.  
(See **Figure 3.9**)
- (3) The screen will change as show in **Figure 3.10-a**.
- (4) Press the “ENVIRO MODE ON” button for 3 seconds on the LCD.  
Then the screen will change as shown in **Figure 3.10-b**.
- (5) After a few seconds, the UPS will be transferred to the Enviro-mode from the inverter source. (Contactor 52S OFF, 52C ON / ESTS ON, Inverter gate block)
- (6) Press the “MAIN” key.
- (7) The screen will change as shown in **Figure 3.11**.

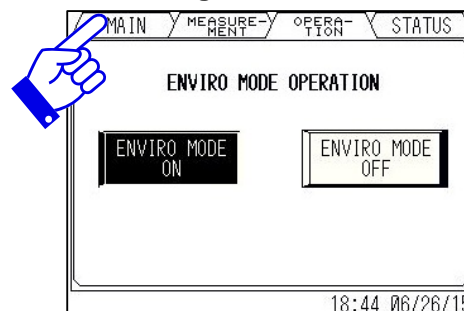
**Figure 3.9**

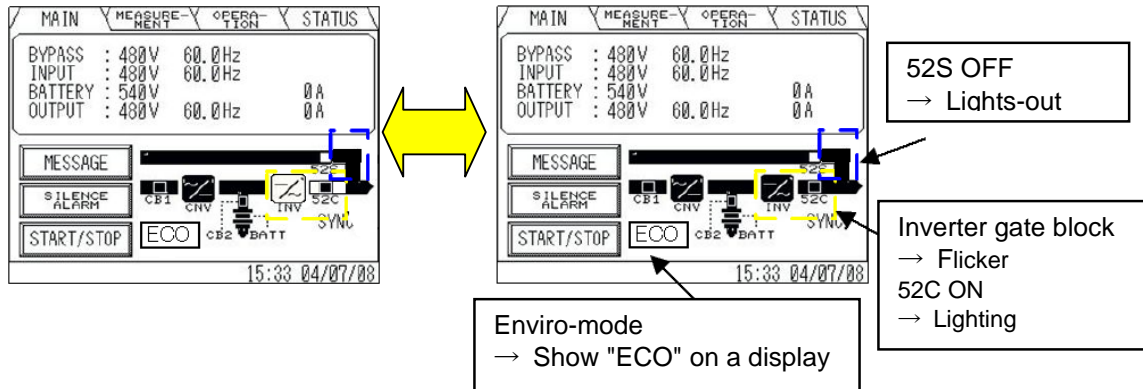


**Figure 3.10-a**



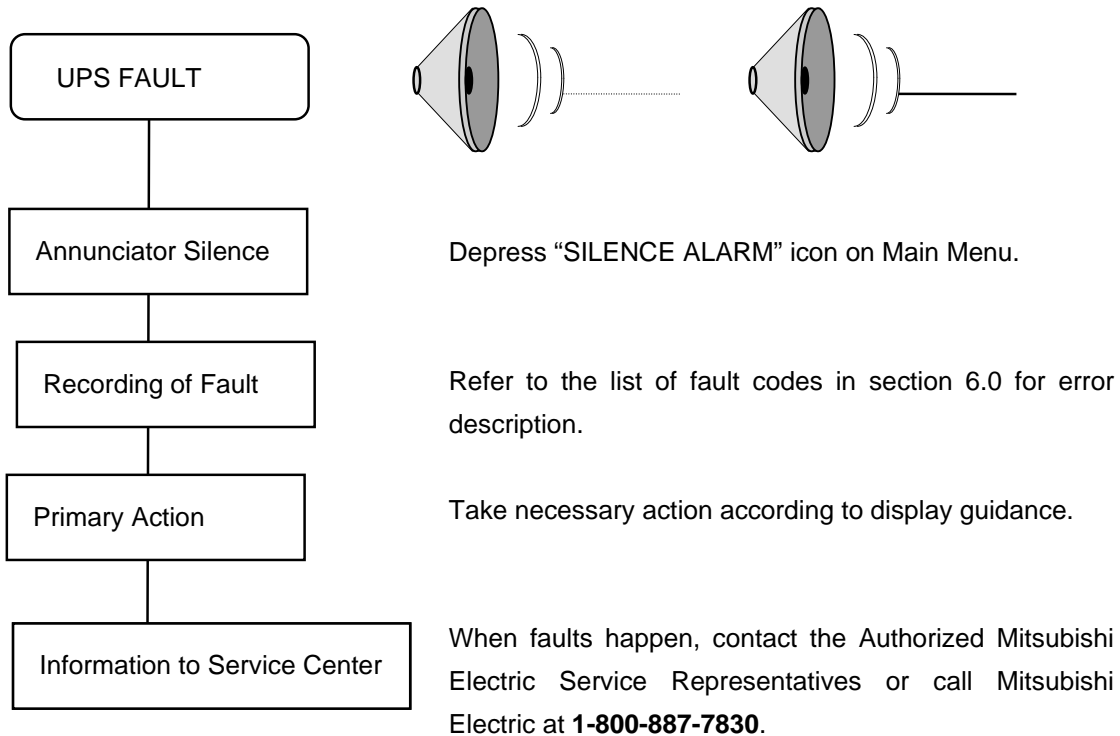
**Figure 3.10-b**



**Figure 3.11**


#### F) Enviro-mode Escaping Procedure (Enviro-mode → Inverter)

- (1) Press the "OPERATION" key in MAIN menu on the LCD. (Figure 3.11)
- (2) Press the "ENVIRO MODE OPERATION" key in OPERATION MENU on the LCD. (See Figure 3.9)
- (3) Press the "ENVIRO MODE OFF" button for 3seconds on the LCD Figure 3.10-b.
- (4) Then the screen will change as shown in Figure 3.10-a.
- (5) The UPS will be transferred to the inverter source from the Enviro-mode after starting the inverter.

**4.0 RESPONSE TO UPS FAILURE****Note**

The error code indicated on the LCD display panel when an UPS alarms is very important.

In order to reduce repair time, please include this information, along with the operation and load status for all correspondence to Mitsubishi Electric field service group.



## 5.0 PARTS REPLACEMENT

Contact Mitsubishi Electric Power Products, Inc. or its authorized service representatives on all issues regarding the replacement of parts.

### A) Battery

Battery lifetime may vary according to the frequency of use and the average ambient operating temperature. The end of battery life is defined as the state of charge resulting in an ampere-hour capacity less than, or equal to, 80% of nominal capacity. Replace battery if its capacity is within this percentage.

### B) UPS Component Parts

UPS components have a defined life expectancy (Fan, Capacitors, Filters, etc).

Contact Mitsubishi Electric Power Products, Inc. or its authorized service representatives for a complete parts replacement schedule. Recommended replacement time interval varies with operating environment.

Contact Mitsubishi Electric Power Products, Inc. or its authorized service representatives for application specific recommendations.



**NOTE :** *Any parts replacements (including modification) without authorized by Mitsubishi could result in personal injuries, death or destruction of the UPS.*

## **6.0 FAULT CODES**

This section covers fault codes, their description and required action.

At time of error :

- A) Verify and record the occurrence of the alarm. Note details of alarm message displayed on the LCD display panel.

***Contact Mitsubishi Electric Power Products, Inc. at 1-800-887-7830.***

- B) If a circuit breaker (MCCB) has tripped, depress the toggle to reset the breaker before closing it again.

**Failure Code List**
**Table 6.1 Fault Code**

Code indication (Note 3)	Status message	Meaning	Guidance	Buzzer	External relay contact (Note 1)	Failure Lamp (Note 2)
UA801	AC INPUT VOLTAGE OUT OF RANGE	Input line voltage is out of the specified range. (Detection Level: <78%, >116%)	CHECK INPUT POWER SOURCE	Intermittent sound	Alarm AC input abnormal	—
UA802	AC INPUT FREQUENCY OUT OF RANGE	Input line frequency is out of the specified range. (Detection Level: +/-11%)	CHECK INPUT POWER SOURCE	Intermittent sound	Alarm AC input abnormal	—
UA803	AC INPUT PHASE ROTATION ERROR	Input line power wiring are not connected in a proper phase sequence.	CHECK INPUT POWER SOURCE	Intermittent sound	Alarm AC input abnormal	—
UA804	CONVERTER OPE. PROHIBITION	The converter interlock is active.	—	Intermittent sound	Alarm	—
UA805	INVERTER OVERLOAD	The output load current has exceeded the rated current.	WARNING : DECREASE LOAD	Intermittent sound	Alarm Overload	Lit on
UA806	INVERTER OVERLOAD	The output load current has exceeded 105% of the rated current.	WARNING : DECREASE LOAD	Intermittent sound	Alarm Overload	Lit on
UA807	INVERTER OVERLOAD	The output load current has exceeded 125% of the rated current.	WARNING : DECREASE LOAD	Intermittent sound	Alarm Overload	Lit on
UA808	INVERTER OVERLOAD	The output load current has exceeded 150% of the rated current.	WARNING : DECREASE LOAD	Intermittent sound	Alarm Overload	Lit on
UA810	INVERTER OVERLOAD	Short-time over-current has been detected during the inverter operation.	WARNING : DECREASE LOAD	Intermittent sound	Alarm Overload	Lit on
UA812	BYPASS VOLTAGE OUT OF RANGE	Bypass line voltage is out of the specified range. (Detection Level: <87%, >112%)	CHECK BYPASS INPUT	Intermittent sound	Alarm Bypass input abnormal	—
UA813	BYPASS PHASE ROTATION ERROR	Bypass line power wiring are not connected in a proper phase sequence.	CHECK BYPASS INPUT	Intermittent sound	Alarm Bypass input abnormal	—
UA814	BYPASS FREQUENCY OUT OF RANGE	Bypass line frequency is out of the specified range. (Detection Level: Frequency Bandwidth +0.2%)	CHECK BYPASS INPUT	Intermittent sound	Alarm Bypass input abnormal	—
UA815	TRANSFER PROHIBITION	Transfer to the bypass is not available due to bypass abnormality.	—	Intermittent sound	Alarm	—
UA817	EMERGENCY STOP ACTIVATED	The emergency stop was activated by EPO switch or external contact.	—	—	Alarm	—

Code indication (Note 3)	Status message	Meaning	Guidance	Buzzer	External relay contact (Note 1)	Failure Lamp (Note 2)
UA821	TRANSFER PROHIBITION	The UPS could not transfer to the bypass because the inverter output was not synchronized to the bypass.	—	—	Alarm	—
UA822	TRANSFER PROHIBITION	The UPS could not transfer to the bypass because of backup generator operation.	—	—	Alarm	—
UA824	CB2 OPEN	The battery circuit breaker (CB2) is open.	TURN ON CB2	Intermittent sound	Alarm	—
UA827	52C OPE. PROHIBITION	The interlock for the inverter output contactor (52C) is active.	—	Intermittent sound	Alarm	—
UA828	COOLING FAN ABNORMAL	Thermal relay activated protection.	CALL SERVICE ENGINEER	Intermittent sound	Alarm	—
UA831	EMERGENCY BYPASS SWITCH ON	Emergency bypass switch has been turned on.	—	Intermittent sound	Alarm	—
UA833	52L OPEN	The load circuit breaker(52L) is turned off.	—	Intermittent sound	Alarm	—
UA834	BATTERY DEPLETED/AC OUT STOPPED	The battery voltage has reached the depleted level (400V).	—	—	Major End-of-disc harge	—
UA835	TRANSFER PROHIBITION	The UPS could not transfer to the bypass because the bypass source has an abnormality.	—	—	Alarm	—
UA860	REMOTE BUTTON ABNORMAL	Remote start or stop signal is being received continuously for a considerable time.	—	Intermittent sound	Alarm	—
UA861	LOCAL BUTTON ABNORMAL	Local start or stop signal is being received continuously for a considerable time.	—	Intermittent sound	Alarm	—
UA870	BALANCER OVERLOAD	DC unbalance is detected before 52 close.	—	Intermittent sound	Alarm	—
UA871	BYPASS VOLTAGE OUT OF RANGE (2)	Bypass line voltage is out of the specified range. (Enviro to INV transferring occurs 3 times in 5minutes.)	CALL SERVICE ENGINEER	Intermittent sound	Minor	Flicker
UA890	EXTERNAL ALARM	External alarm is activated.	—	Intermittent sound	Alarm	—
UF001	INPUT CIRCUIT ABNORMAL	Detection of a large variation of the reference error signal.	CALL SERVICE ENGINEER	Continuous sound	Major	Lit on
UF002	CONVERTER OVERCURRENT	Detection of converter overcurrent. (Detection Level: 280%peak )	CALL SERVICE ENGINEER	Continuous sound	Major	Lit on
UF003	CONVERTER ABNORMAL	Pre-charging circuit is not working properly.	CALL SERVICE ENGINEER	Continuous sound	Major	Lit on
UF011	CB1 ABNORMAL	Major discrepancy between reference signal and actual state of contactor CB1.	CALL SERVICE ENGINEER	Continuous sound	Major	Lit on
UF052	CB1 ABNORMAL	Minor discrepancy between reference signal and actual state of contactor CB1.	CALL SERVICE ENGINEER	Intermittent sound	Minor	Flicker
UF056	CONVERTER OVERCURRENT	Detection of converter overcurrent. (Detection Level: 280%peak )	CALL SERVICE ENGINEER	Intermittent sound	Minor	Flicker
UF059	INPUT CIRCUIT ABNORMAL	Detection of a large variation of the reference error signal.	CALL SERVICE ENGINEER	Intermittent sound	Minor	Flicker

Code indication (Note 3)	Status message	Meaning	Guidance	Buzzer	External relay contact (Note 1)	Failure Lamp (Note 2)
UF102	DC OVERVOLTAGE	DC voltage surpasses the overvoltage level. (Detection Level: >880Vdc )	CALL SERVICE ENGINEER	Continuous sound	Major	Lit on
UF103	DC UNDERVOLTAGE	DC voltage dropped below the undervoltage level. (Detection Level: <630Vdc )	CALL SERVICE ENGINEER	Continuous sound	Major	Lit on
UF108	CHOPPER OVERCURRENT	Detection of DC overcurrent. (Detection Level: 290%peak )	CALL SERVICE ENGINEER	Continuous sound	Major	Lit on
UF109	DC UNBALANCED	Major unbalance of the neutral point voltage. (Detection Level: dV>150Vdc )	CALL SERVICE ENGINEER	Continuous sound	Major	Lit on
UF110	ZERO PHASE OVERCURRENT	Detection of converter zero-sequence overcurrent.(Detection Level: >50% )	CALL SERVICE ENGINEER	Continuous sound	Major	Lit on
UF112	DC CIRCUIT ABNORMAL	Sudden change of the DC voltage level.	CALL SERVICE ENGINEER	Continuous sound	Major	Lit on
UF119	DC GROUND FAULT	Detection of DC ground fault.	CALL SERVICE ENGINEER	Continuous sound	Major	Lit on
UF128	CONTROL POWER SUPPLY ABNORMAL	Power supply voltage to IGBT driver PCB is below the specified level.	CALL SERVICE ENGINEER	Continuous sound	Major	Lit on
UF151	DC VOLTAGE ABNORMAL	24 hours after input power restoration, batteries does not reach float voltage level.	CALL SERVICE ENGINEER	Intermittent sound	Minor	Flicker
UF152	DC VOLTAGE ABNORMAL	Unable to equalize the voltage of battery.	CALL SERVICE ENGINEER	Intermittent sound	Minor	Flicker
UF154	CB2 ABNORMAL	During UVT, status signal from CB2 is ON.	CALL SERVICE ENGINEER	Intermittent sound	Minor	Flicker
UF156	CHG.STOPPED (BATTERY OVERTEMP.)	UF157 failure persisted for over 2 hours.	CHECK BATTERY	Intermittent sound	Minor Battery abnormal	Flicker
UF157	BATTERY OVERTEMPERATURE	Detection of overtemperature at the batteries.	CHECK BATTERY	Intermittent sound	Minor Battery abnormal	Flicker
UF158	BATTERY LIQUID LOW	Low level of battery electrolyte solution.	CHECK BATTERY	Intermittent sound	Minor Battery abnormal	Flicker
UF159	DC GROUND FAULT	Detection of DC ground fault.	CALL SERVICE ENGINEER	Intermittent sound	Minor	Flicker
UF161	CHG.STOPPED (DC VOLT. ABNORMAL)	UF151 failure is running for over 24 hours.	CALL SERVICE ENGINEER	Intermittent sound	Minor	Flicker
UF162	BATTERY ABNORMAL	Failure detection based on battery self-check.	CALL SERVICE ENGINEER	Intermittent sound	Minor	Flicker
UF163	BATTERY VOLTAGE ABNORMAL	Battery voltage is abnormality.	CALL SERVICE ENGINEER	Intermittent sound	Minor	Flicker

Code indication (Note 3)	Status message	Meaning	Guidance	Buzzer	External relay contact (Note 1)	Failure Lamp (Note 2)
UF172	CHG. STOPPED (DEVICE STATUS)	Energy storage device error.	CALL SERVICE ENGINEER	Intermittent sound	Minor	Flicker
UF201	INVERTER OVERVOLTAGE	Detection of output overvoltage.	CALL SERVICE ENGINEER	Continuous sound	Major	Lit on
UF202	INVERTER UNDERVOLTAGE	Output voltage dropped.	CALL SERVICE ENGINEER	Continuous sound	Major	Lit on
UF203	INVERTER OVERCURRENT	Detection of inverter overcurrent.	CALL SERVICE ENGINEER	Continuous sound	Major	Lit on
UF204	OUTPUT CIRCUIT ABNORMAL	Detection of a large variation of the reference error signal (current reference and actual current).	CALL SERVICE ENGINEER	Continuous sound	Major	Lit on
UF206	UPS CONTROL CIRCUIT ERROR	Discrepancy between output voltage and external voltage (bypass, common ac bus)	CALL SERVICE ENGINEER	Continuous sound	Major	Lit on
UF207	ZERO PHASE OVERCURRENT	Inverter zero-sequence overcurrent.	CALL SERVICE ENGINEER	Continuous sound	Major	Lit on
UF208	UPS CONTROL CIRCUIT ERROR	Cross current is abnormality.	CALL SERVICE ENGINEER	Continuous sound	Major	Lit on
UF209	52C ABNORMAL	Error to close the contactor 52C.	CALL SERVICE ENGINEER	Continuous sound	Major	Lit on
UF210	52C ABNORMAL	Error to open the contactor 52C.	CALL SERVICE ENGINEER	Continuous sound	Major	Lit on
UF211	52C ABNORMAL	No answer from contactor 52C during inverter operation.	CALL SERVICE ENGINEER	Continuous sound	Major	Lit on
UF213	OVERTEMPERATURE	Heatsinks temperature exceeds thermal settings.	CALL SERVICE ENGINEER	Continuous sound	Major	Lit on
UF214	COOLING FAN ABNORMAL	Thermal relay activated protection.	CALL SERVICE ENGINEER	Continuous sound	Major	Lit on
UF217	INVERTER OVERVOLTAGE	Detection of inverter output phase overvoltage.	CALL SERVICE ENGINEER	Continuous sound	Major	Lit on
UF230	ZERO PHASE OVERCURRENT	Detection of zero-sequence overcurrent.	CALL SERVICE ENGINEER	Continuous sound	Major	Lit on
UF253	UPS CONTROL CIRCUIT ERROR	Discrepancy between output voltage and inverter voltage, or between output voltage and bypass voltage.	CALL SERVICE ENGINEER	Intermittent sound	Minor	Flicker
UF256	OUTPUT VOLTAGE ABNORMAL	Output voltage is out of the specified range.	CALL SERVICE ENGINEER	Intermittent sound	Minor	Flicker
UF257	52C ABNORMAL	Contactor 52C failed to open during load transfer from inverter to bypass.	CALL SERVICE ENGINEER	Intermittent sound	Minor	Flicker

Code indication (Note 3)	Status message	Meaning	Guidance	Buzzer	External relay contact (Note 1)	Failure Lamp (Note 2)
UF258	LOAD ABNORMAL	Load transfer due to overload for over 4 times within 5 minutes.	CALL SERVICE ENGINEER	Intermittent sound	Minor	Flicker
UF259	ANOTHER UPS ABNORMAL	No detection of another UPS voltage signal.	CALL SERVICE ENGINEER	Intermittent sound	Minor	Flicker
UF301	UPS CONTROL CIRCUIT ERROR	AD reference has an abnormal value.	CALL SERVICE ENGINEER	Continuous sound	Major	Lit on
UF302	UPS CONTROL CIRCUIT ERROR	Detection of an external interruption during the software execution.	CALL SERVICE ENGINEER	Continuous sound	Major	Lit on
UF303	UPS CONTROL CIRCUIT ERROR	Timer does not reset in the specified period (WDT settings)	CALL SERVICE ENGINEER	Continuous sound	Major	Lit on
UF305	UPS CONTROL CIRCUIT ERROR	Detection of an abnormal clock speed in the DSP or FPGA.	CALL SERVICE ENGINEER	Continuous sound	Major	Lit on
UF306	UPS CONTROL CIRCUIT ERROR	Control power supply voltage are below the specified level.	CALL SERVICE ENGINEER	Continuous sound	Major	Lit on
UF309	INVERTER VOLTAGE ABNORMAL	Inverter voltage is out of the specified range.	CALL SERVICE ENGINEER	Continuous sound	Major	Lit on
UF310	CONTROL POWER SUPPLY ABNORMAL	Backup control power supplies exhibit abnormal condition.	CALL SERVICE ENGINEER	Continuous sound	Major	Lit on
UF323	UPS CONTROL CIRCUIT ERROR	Major communication error during parallel operation.	CALL SERVICE ENGINEER	Continuous sound	Major	Lit on
UF331	UPS CONTROL CIRCUIT ERROR	Cable disconnection in the main driver PCB (Phase U).	CALL SERVICE ENGINEER	Continuous sound	Major	Lit on
UF332	UPS CONTROL CIRCUIT ERROR	Cable disconnection in the main driver PCB (Phase V).	CALL SERVICE ENGINEER	Continuous sound	Major	Lit on
UF333	UPS CONTROL CIRCUIT ERROR	Cable disconnection in the main driver PCB (Phase W).	CALL SERVICE ENGINEER	Continuous sound	Major	Lit on
UF334	UPS CONTROL CIRCUIT ERROR	Cable disconnection in the main driver PCB (Chopper).	CALL SERVICE ENGINEER	Continuous sound	Major	Lit on
UF352	CONTROL POWER SUPPLY ABNORMAL	Backup control power supplies exhibit abnormal condition.	CALL SERVICE ENGINEER	Intermittent sound	Minor	Flicker

Code indication (Note 3)	Status message	Meaning	Guidance	Buzzer	External relay contact (Note 1)	Failure Lamp (Note 2)
UF363	UPS CONTROL CIRCUIT ERROR	Synchronization status signal is being received for a considerable time.	CALL SERVICE ENGINEER	Intermittent sound	Minor	Flicker
UF371	UPS CONTROL CIRCUIT ERROR	Minor communication error during parallel operation.	CALL SERVICE ENGINEER	Intermittent sound	Minor	Flicker
UF372	UPS CONTROL CIRCUIT ERROR	Unable to synchronize the inverter output and the bypass voltage.	CALL SERVICE ENGINEER	Intermittent sound	Minor	Flicker
UF374	UPS CONTROL CIRCUIT ERROR	Cable disconnection in the parallel interface board.	CALL SERVICE ENGINEER	Intermittent sound	Minor	Flicker
UF375	UPS CONTROL CIRCUIT ERROR	Unable to achieve synchronization for parallel operation.	CALL SERVICE ENGINEER	Intermittent sound	Minor	Flicker
UF376	UPS CONTROL CIRCUIT ERROR	No control response from another UPS although its detection is possible.	CALL SERVICE ENGINEER	Intermittent sound	Minor	Flicker
UF377	UPS CONTROL CIRCUIT ERROR	Overload detection signal is being received continuously for a considerable time.	CALL SERVICE ENGINEER	Intermittent sound	Minor	Flicker
UF378	UPS CONTROL CIRCUIT ERROR	No answer for sending synchronizing signal.	CALL SERVICE ENGINEER	Intermittent sound	Minor	Flicker
UF379	UPS CONTROL CIRCUIT ERROR	Abnormal clock speed of the parallel control board processor.	CALL SERVICE ENGINEER	Intermittent sound	Minor	Flicker
UF380	ESTS CONTROL CIRCUIT ERROR	Control power supply voltage for ESTS is abnormal.	CALL SERVICE ENGINEER	Intermittent sound	Minor	Flicker
UF381	ESTS CONTROL CIRCUIT ERROR	Assist current is abnormality.	CALL SERVICE ENGINEER	Intermittent sound	Minor	Flicker
UF401	52S ABNORMAL	Error to close the contactor 52S.	CALL SERVICE ENGINEER	Continuous sound	Major	Lit on
UF402	52S ABNORMAL	Error to open the contactor 52S.	CALL SERVICE ENGINEER	Continuous sound	Major	Lit on
UF420	52L OPERATION ERROR	Load circuit breaker 52L opened during inverter operation.	CHECK 52L	Continuous sound	Major	Lit on
UF451	52S ABNORMAL	Contactor 52S failed during load transfer from inverter to bypass.	CALL SERVICE ENGINEER	Intermittent sound	Minor	Flicker
UF452	CB3 ABNORMAL	Contactor CB3 is not working properly.	CALL SERVICE ENGINEER	Intermittent sound	Minor	Flicker



Code indication (Note 3)	Status message	Meaning	Guidance	Buzzer	External relay contact (Note 1)	Failure Lamp (Note 2)
UF461	OVERTEMPERATURE	Heatsinks temperature for ESTS exceeds thermal settings.	CALL SERVICE ENGINEER	Intermittent sound	Minor	Flicker

- (Note 1) 1) "Major" is defined as major failure. Inverter transferred to the static bypass line;  
 2) "Minor" is defined as a minor failure. UPS continues to operate normally, but cause of alarm must be identified;

(Note 2) Indicates one of two possible LED illumination patterns - continuously on (lit on) or intermittent (flicker).

(Note 3) Code indication means:

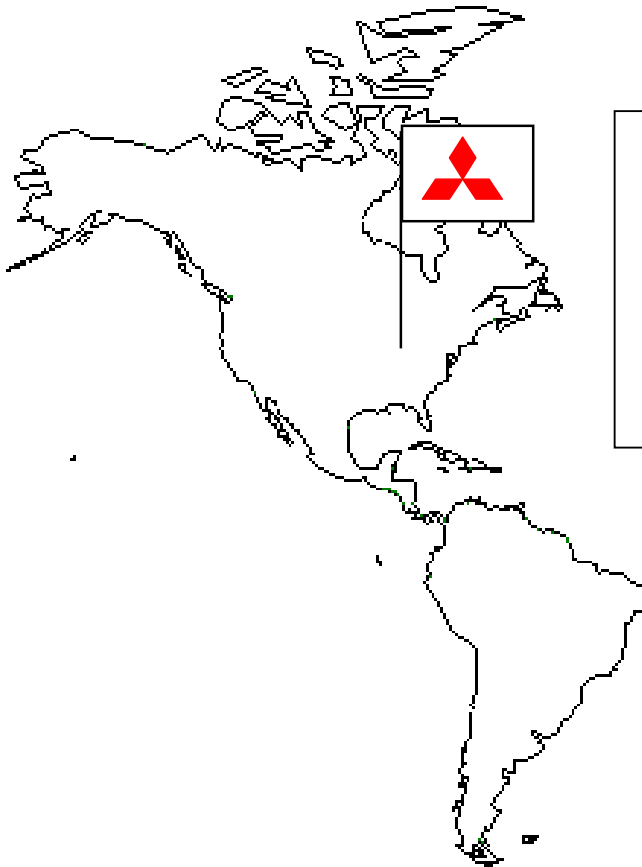
UA+++ ----- Alarm  
 UF+++ ----- Failure  
 U%0++ ----- Rectifier circuit failure  
 U%1++ ----- DC circuit failure  
 U%2++ ----- Inverter circuit failure  
 U%3++ ----- Control circuit failure  
 U%4++ ----- Bypass system failure  
 U%8++ ----- Alarm  
 U%+00 - U%+49 ----- Major failure  
 U%+50 - U%+99 ----- Minor failure

- \*) "+" denotes any numeral from 0 to 9  
 \*) "%" denotes either "A" or "F"

## 7.0 WARRANTY & OUT OF WARRANTY SERVICE

The Mitsubishi Electric UPS Division Service Department has many Authorized Service Centers place strategically throughout the US, Canada and Latin America. For both in warranty and out of warranty service, please contact Mitsubishi Electric Power Products, Inc. at (724) 772-2555. To register your UPS for warranty purposes, please complete the warranty registration form and fax it to the Mitsubishi Electric UPS Division Service Department fax line shown on the registration form. (Next page)

For warranty purposes, it is essential that any and all service work that may be required on your Mitsubishi brand UPS equipment is performed by a Mitsubishi Electric Authorized Service Center. The use of non-authorized service providers may void your warranty.



**Mitsubishi Electric Power Products, Inc**  
UPS Division Service Department

530 Keystone Drive,  
Warrendale, PA 15086, USA  
Phone: (724) 772-2555  
Fax: (724) 778-3146


**Mitsubishi Electric Power Products, Inc.**

UNINTERRUPTIBLE POWER SUPPLIES

530 Keystone Drive, Warrendale, PA 15086

Phone: (724) 772-2555, Fax: (724) 778-3146

## UPS Warranty Registration

 Register UPS for Warranty

 Address Change

**To validate the Warranty on your UPS this form must be filled out completely by Customer and returned.**

CUSTOMER INFORMATION			
Your Name:		Job Title:	
Company Name:			
Division / Department:			
Address:			
City:		State:	Zip Code:
Country:		Province:	
Business Phone:		Ext:	Fax:
E-Mail:		Internet Address:	
UPS Model #:		Capacity (kVA):	UPS Serial #:
Start-Up Date:        /        /		Authorized Mitsubishi Service Company (if known):	
Signature:		Date:        /        /	

**Which ONE of These Best Describes Your Organization's  
Primary Business Classification?**
**Number of Employees at This Location is:**
 {Energy Producer}

 Utility  
 Alternate Energy

 {Manufacturing Co.}

 OEM  
 Process

 Consumer Goods

 Electronics  
 Power Quality Equipment

 Commercial Business

 Electrical Contractor

 Healthcare

 Internet

 Education/Univ. Service

**{Service}**
 Consulting

 Engineering

 Outsourcing

 Financial/Legal/Insurance  
 {Expectations}

**{Government}**
 Military

 Municipals

 Federal/State/Local

 Communications

 Distributors/Reps

 Other \_\_\_\_\_

 1 - 19

 20 - 49

 50 - 99

 100 - 249

 250 - 499

 500 - 999

 1000 or more

**Overall how was Start-Up performed:**
 Unsatisfactory

 Satisfactory

 Exceeded

**Would you like to receive future product updates and news?**
 Yes

 No

**After Start-Up has been done Fax completed Form to:  
(724) 778-3146**

