



UNINTERRUPTIBLE POWER SUPPLY SYSTEM

MODEL

# 9900D SERIES

OWNER'S / TECHNICAL MANUAL

(Inclusive Parallel Operation System Application)

**UNINTERRUPTED** Peace of Mind®

# Preface

**TABLE OF CONTENTS**

LIST OF TABLES .....	ii
LIST OF FIGURES .....	iii
HOW TO USE THIS MANUAL .....	iv
<b>1.0 INTRODUCTION .....</b>	<b>1-1</b>
1.1 SAFETY PRECAUTION .....	1-2
1.2 GENERAL .....	1-5
1.3 DEFINITIONS .....	1-6
1.4 OPERATION OVERVIEW .....	1-7
1.5 SPECIFICATIONS .....	1-13
<b>2.0 OPERATION CONTROLS AND INDICATORS .....</b>	<b>2-1</b>
2.1 LED DISPLAY .....	2-2
2.2 EPO BUTTON .....	2-2
2.3 LIQUID CRYSTAL DISPLAY .....	2-2
2.4 EXTERNAL SIGNAL TERMINAL BLOCK .....	2-8
2.5 EXTERNAL COMMUNICATION CONNECTOR .....	2-15
<b>3.0 INSTALLATION AND STORAGE.....</b>	<b>3-1</b>
3.1 STORAGE AND HANDLING .....	3-1
3.2 INSTALLATION PROCEDURE .....	3-2
3.3 PROCEDURE FOR CABLE CONNECTIONS .....	3-6
3.4 CONNECTION OF BATTERY UVR SIGNAL .....	3-15
<b>4.0 OPERATING PROCEDURES .....</b>	<b>4-1</b>
<b>5.0 RESPONSE TO UPS FAILURE .....</b>	<b>5-1</b>
<b>6.0 PARTS REPLACEMENT .....</b>	<b>6-1</b>
<b>7.0 FAULT CODES .....</b>	<b>7-1</b>
<b>8.0 WARRANTY INFORMATION .....</b>	<b>8-1</b>
<b>9.0 MAINTENANCE CONTRACTS .....</b>	<b>9-1</b>
9.1 SERVICE OFFERINGS .....	9-1
9.2 PACKAGES .....	9-1

**LIST OF TABLES**

Table 1.1	UPS Installation Environment.....	1-4
Table 1.2	Rating of Bypass Input Circuit Breaker .....	1-5
Table 1.3	Power Specifications .....	1-13
Table 1.4	UPS Cabinet Information.....	1-13
Table 1.5	Detail of Specifications .....	1-14
Table 1.6	Rating of Contactors, Breakers and Fuses .....	1-15
Table 2.1	Selectable Items for Output Contacts.....	2-11
Table 2.2	Selectable Items for Input Contacts.....	2-14
Table 3.1	List of UPS Weights.....	3-4
Table 3.2	Maximum Permitted Fault Current.....	3-5
Table 3.3	Recommended Cable Sizes .....	3-8
Table 3.4	Recommended Hardware.....	3-8
Table 3.5	Crimp Type Compression Lug.....	3-9
Table 7.1	Bypass Module Fault Code List.....	7-2
Table 7.2	UPS Module Fault Code List .....	7-7
Table 9.1	Typical Offerings .....	9-1

**LIST OF FIGURES**

Figure 1.1	Single Line Diagram- Normal Operation: Load powered by UPS inverter .....	1-7
Figure 1.2	Single Line Diagram- Bypass Operation: Load Fed through static bypass line.....	1-8
Figure 1.3	Single Line Diagram-Battery Operation.....	1-9
Figure 1.4	UPS Parts Location .....	1-11
Figure 2.1	Operation/Display Panel .....	2-1
Figure 2.2	Main Screen.....	2-3
Figure 2.3(a)	Start/Stop Operation .....	2-4
Figure 2.3(b)	Start Operation.....	2-4
Figure 2.3(c)	Stop Operation.....	2-4
Figure 2.4(a)	Input Values .....	2-4
Figure 2.4(b)	Output Values .....	2-4
Figure 2.5	Remote/Local Operation or Date & Time Adjustment Select.....	2-5
Figure 2.6(a)	Log Menu .....	2-5
Figure 2.6(b)	Event Log.....	2-6
Figure 2.6(c)	Battery Log.....	2-6
Figure 2.7	Main Screen (Battery Operation).....	2-6
Figure 2.8	Main Screen (Fault Indication).....	2-7
Figure 2.9	Message Screen .....	2-7
Figure 2.10(a)	External Signal Terminal Block TN21-25 (NEC Class2) .....	2-8
Figure 2.10(b)	External Signal Terminal Block TN11-14 (NEC Class2) .....	2-9
Figure 2.11	Control Wiring for External Contacts .....	2-10
Figure 2.12	Remote "Start" Contact Connections .....	2-12
Figure 2.13	External Communication Connector.....	2-15
Figure 3.1	Forklift Lifting Side .....	3-1
Figure 3.2	Side that cannot be Lifted .....	3-1
Figure 3.3	UPS Center of Gravity Markers .....	3-2
Figure 3.4	Acceptable and Unacceptable UPS Alignment .....	3-3
Figure 3.5	Shim Contact Around Base Channel Mounting Holes .....	3-4
Figure 3.6	UPS Terminal Designation .....	3-9
Figure 3.7	Diagram of Input/Output Bus Bars and Terminal Blocks .....	3-10
Figure 3.8	Diagram of Power Wire and Control Wire Interconnection between UPS and Battery .....	3-11
Figure 3.9	Diagram of power wire connections (Parallel Operation system connection) .....	3-12
Figure 3.10(a)	Diagram of Power Wire & Control Wire Connect (Parallel Operation system connection 2x to 8x) .....	3-13
Figure 3.10(b)	Outline Drawing of IFAU-16 and the Parallel System Operation Connection .....	3-14
Figure 3.11	UVR Terminal Block .....	3-15
Figure 3.12	Diagram of UVR and UPS Connections .....	3-15

## HOW TO USE THIS MANUAL

This manual is designed for ease of use, giving the user easy and quick reference to information. This manual uses notice icons to draw attention to the user important information regarding the safe operation and installation of the UPS. The notice icons used in this manual are explained below, and should be taken into account and adhered to whenever they appear in the text of this manual.



**Warning:** A warning symbol shows potentially hazardous situations or conditions that can result in personal injury or death, if not avoided.



**Caution:** A caution symbol shows potentially hazardous situations or conditions which can result in personal injury or equipment damage, if not avoided.



**Note:** A Note symbol shows the information the user or the service personnel should observe during UPS operation or service work.



**Prohibit:** A prohibit symbol shows the act the user or the service personnel should NEVER perform during the UPS installation, operation or service work.

### DEFINITIONS:

**Shall** – Imperative command that *must* be followed by the user. Failure to adhere to “shall” commands may void warranty.

**Should** – Command highly recommended by Mitsubishi for best UPS operation and performance but not required by user to maintain warranty.

**NOTE**

**FAILURE TO FOLLOW MANUAL  
INSTRUCTIONS VOIDS WARRENTY  
AND MAY AFFECT OPERATION**

## 1.0 INTRODUCTION

The Mitsubishi Uninterruptible Power Supply System (UPS) is designed to provide many years of reliable protection from power failure, brown-outs, line noise, and voltage transients. To ensure optimum performance of the equipment, follow the manufacturer's instructions. This manual contains descriptions required to operate the UPS. Please read this manual carefully and retain it for future reference.



**IMPORTANT SAFETY INSTRUCTIONS  
SAVE THESE INSTRUCTIONS**

This manual contains important instructions for the 9900D SERIES Uninterruptible Power Supply System that should be followed during installation and maintenance of the UPS and batteries.



**WARNING 1**

**Lethal voltages exist within the equipment during operation. Observe all warning and cautions in this manual. Failure to comply may result in serious injury or death. Obtain qualified service for this equipment as instructed.**



**WARNING 2****1.1 SAFETY PRECAUTIONS**

In order to maintain safety and perform start-up and maintenance of the UPS system successfully, certified service personnel familiar with the operation of this equipment must be involved. The following safety practices should always be followed.

**PRECAUTIONS DURING INSTALLATION** **CAUTION**

- Do not block the ventilation ports. The ventilation ports should be arranged so that walls or ceilings do not block ventilation. (Maintenance spaces described in the catalogue or external drawings should be followed.)  
If a ventilation port is blocked, the internal temperature of the UPS will rise, and consequently, a fire may be caused due to liquid leakage from batteries, short-circuits, or parts deterioration.

**PRECAUTIONS FOR WIRING** **CAUTION**

- Ask professional agents for wiring work. Inappropriate wiring work may cause electric shocks, injuries, or fire.

**PRECAUTIONS TO PROFESSIONAL AGENTS** **CAUTION**

- Use wiring conduit, pits or racks for input/output wiring. Inadvertent wiring may cause injuries.
- Use terminals for connection to the input/output terminals. Inadvertent connection may cause electric shocks.
- Do not drop dust or any other thing from the fan hole.

**PRECAUTIONS FOR UPS OR UPS PARTS DISPOSAL** **CAUTION**

- Since the UPS contain special industrial waste, such as capacitors, insulators or batteries, they cannot be disposed of like other general waste. Please check the disposal guideline of your district, contact the specialized contractor for disposal.

**PRECAUTIONS REGARDING BATTERIES**

Before operating the system, carefully read the battery and battery cabinet operating manuals.

 **CAUTION**

- Follow the directions below when using the batteries, otherwise liquid leakage, heat evolution, and explosions may be caused.
  - a. Do not solder the batteries directly.
  - b. Do not charge the battery with its negative and positive terminals reversed.
  - c. Do not use different types or suppliers of batteries, or old and new batteries together.
  - d. Do not remove or damage the armoring tube of the battery.
  - e. Do not render a large impact or throw the battery.
  - f. Use wet cloths for cleaning the battery. Do not use organic solvents such as gasoline and thinner, or oil. Do not wipe the battery with cloths that contain organic solvents or oil. Keep the battery away from flexible vinyl materials.
  - g. Since the electric energy remains in the used batteries, treat them carefully to prevent sparks and short circuits.

**APPLICATION** **CAUTION**

**If the UPS System is to be applied to support equipment that could affect human safety, the following steps must be adhered to:**

1. Consult with Mitsubishi Electric Power Products Inc. UPS Division.
2. Special consideration of the overall back up power system configuration is required so that the Mitsubishi UPS System is not the sole support required for operation, maintenance and management of power availability. Other available power sources; for example utility, emergency power generation or other systems shall also support power availability.

Definition of equipment that could affect human safety:

- Life Support Systems (is a system whose failure to perform can be expected to result in bodily injury or death.)
- Essential Public Systems (is a system whose failure to perform can be expected to result in bodily injury or death and/or property damage.)


**WARNING 3**

**The UPS is to be installed in a controlled environment.**

**Improper storage and installation environment may deteriorate insulation, shorten component life and cause malfunctions.**

**Keep the installation environment per standard described as follows:**

**Table 1.1** UPS Installation Environment

No.	Item	Environment standard	
1	Installation Location	Indoors, without vibrations or impact	
2	Ambient temperature	Minimum temperature: 32°F(0°C), Maximum temperature: 104°F(40°C) The average temperature over any 24-hour period must be in the range 41° F (5°C) to 95°F(35°C).	
3	Relative humidity	The relative humidity must be held between 5 and 95%. There must be no condensation due to temperature changes.	
4	Altitude	This equipment must not be applied at altitude that exceeds 1980m (6500ft) above sea level.	
5	Dust	Dust in the room where the UPS is installed must not exceed normal atmospheric dust levels. In particular, that dust should not include iron particles, oils or fats, or organic materials such as silicone.	
6	Inflammable gas following IEC654-4 Part 4	There should be no inflammable/explosive gas.	
		Sea salts	0
		Hydrogen sulfide (H <sub>2</sub> S)	No more than 0.003 PPM
		Sulfurous acid gas (SO <sub>2</sub> )	No more than 0.01 PPM
		Chlorine gas (Cl <sub>2</sub> )	No more than 0.002 PPM
		Wet Chlorine (Cl <sub>2</sub> ) relative humidity >50%	No more than 0.0005 PPM
		Hydrogen chloride	No more than 0.0066 PPM
		Hydrogen fluoride (HF)	No more than 0.001 PPM
		Ammonia gas (NH <sub>3</sub> )	No more than 1 PPM
		Nitrous oxides (NO <sub>x</sub> )	No more than 0.05 PPM
Ozone (O <sub>3</sub> ) or other oxidants	No more than 0.002 PPM		

**WARNING 4**

This UPS does not include a Bypass input circuit breaker (MCCB) to protect bypass circuit. The Bypass input circuit breaker (MCCB) is to be field supplied and installed. Recommended Breaker (MCCB)'s Specifications are as follows:

**Table 1.2** Rating of Bypass Input Circuit Breaker

Capacity (kVA)	Bypass Voltage (Vac)	Bypass Rating (Aac)	Breaker (A)
1200	480	1443	1600
1250	480	1504	1600
1500	480	1804	2000
1600	480	1925	2000
2000	480	2406	2500

**AC input and AC output overcurrent protection and disconnect devices shall be field supplied and installed. The DC circuit breaker (MCCB) shall be field supplied and installed. The overcurrent protection device should be installed in the Battery cabinet and rated as indicated in Table 1.6.**

## 1.2 GENERAL

The Mitsubishi 9900D SERIES UPS is designed to provide continuous and clean electrical power to a critical load. Additionally the UPS monitors power conditions affecting the load. In the event of an input power failure, the UPS will supply power to the critical load for the specified battery time.

If the input power is not restored promptly, backup power from the UPS battery permits the orderly shutdown of equipment supported by the UPS. The UPS is simple to start-up, operate and maintain.

The 9900D SERIES UPS is available in 1200, 1250, 1500, 1600 and 2000 kVA. Specifications are shown in Section 1.5.

This manual provides an overview of the 9900D SERIES components and their functions. The appearance and purpose of operator controls and indicators is described with procedures for operation, start-up, shutdown and basic maintenance included.

### 1.3 DEFINITIONS

**UNINTERRUPTIBLE POWER SUPPLY SYSTEM (UPS)** – All components within the UPS Cabinet and associated batteries that function as a system to provide continuous, conditioned AC power to a load. This is sometimes referred to as the "System".

**UPS CABINET** – The metal enclosure which is the main part of UPS and composed of the Bypass module, the 2 – 5 UPS modules, and the Cable Entry Section.

**UPS MODULE** – The metal enclosure which contains the Converter / Inverter, Charger, and internal control systems required to provide specified AC power to a load.

**CONVERTER / INVERTER** – The UPS components which contain the equipment and controls necessary to convert input AC power to output AC power required by the critical load.

**CHARGER** – The UPS components which contain the equipment and controls necessary to regulate DC power required for battery charging and for supplying power to the Inverter.

**BYPASS MODULE** – The metal enclosure which contains the Bypass line, the Static transfer switch, UPS operator controls, and internal control systems.

**BYPASS LINE** – The line which conducts electricity directly from the input power source to the critical load during Maintenance or whenever the UPS is not completely operational.

**STATIC TRANSFER SWITCH** – The device which connects the critical load to the bypass line when the Inverter cannot supply continuous power.

**AC INPUT POWER** – Power provided by the electrical utility company, or auxiliary generator, which is connected to the UPS for supplying the critical load.

**BATTERY** – The rechargeable battery strings which supply DC power to the inverter to maintain continuous AC power to the load during AC input power failure conditions.

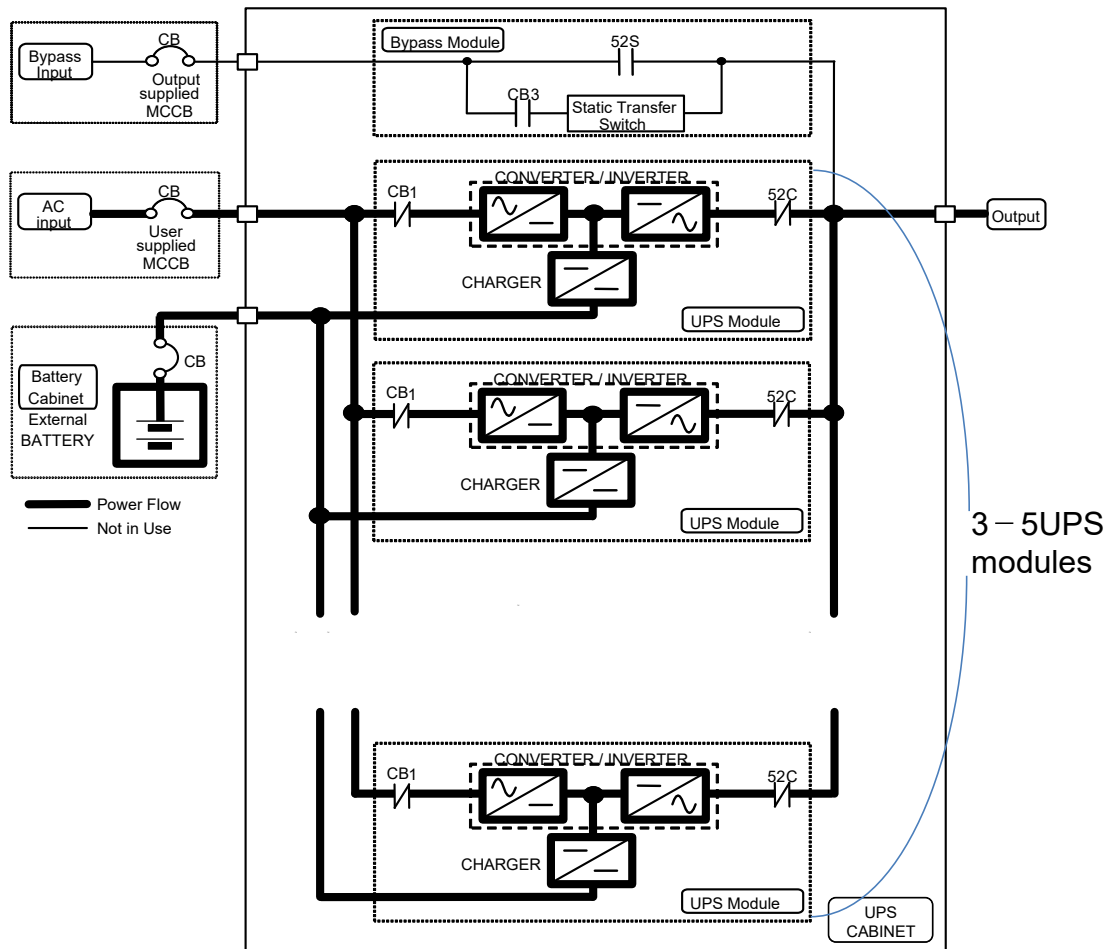
**1.4 OPERATION OVERVIEW**

The UPS provides two power paths between the utility source and the critical load.

Figure 1.1 shows the path for normal operation, with the load powered from the inverter. Figure 1.2 shows the path for bypass operation, with the load supplied through the static bypass line.

**A) Normal operation:** Load power supplied by each system UPS inverter.

**Figure 1.1** Single Line Diagram - Normal Operation: Load powered by UPS inverter



During normal operation, the path through the UPS inverters is used to power the load.

Referring to Figure 1.1: Input AC power is converted to DC by the Converter. DC power is utilized to charge the UPS battery and to provide power to the Inverter. The Inverter converts the DC power to clean AC power to supply the critical load.

The conversion - inversion process eliminates any voltage transients or fluctuations existing in the input power before it reaches the critical load.

The power drawn by the critical load is equally shared between all UPS whenever the system is in the Parallel Operation.

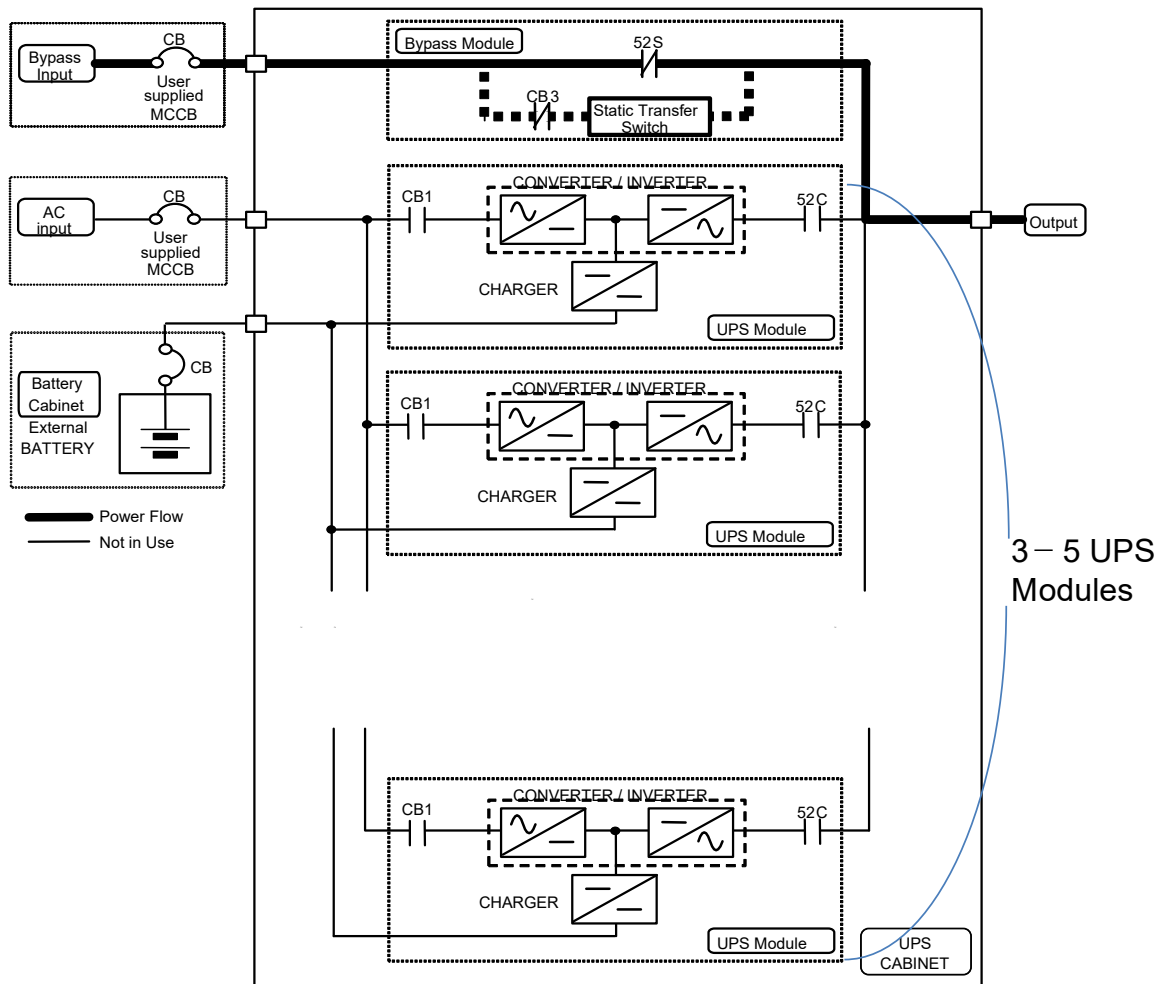


The Bypass Input circuit breaker (MCCB) for protection of the UPS and cables are field supplied and field installed. (See WARNING 4 on page 1-5).

**NOTE**

**B) Bypass Operation:** Load Power supplied through UPS internal static bypass line.

**Figure 1.2** Single Line Diagram - Bypass Operation: Load fed through static bypass line



Referring to Figure 1.2: The Internal Bypass line is a Hard-wired line through 52S which supplies the critical load with unconditioned bypass input power. Upon switching to the Internal Bypass line,

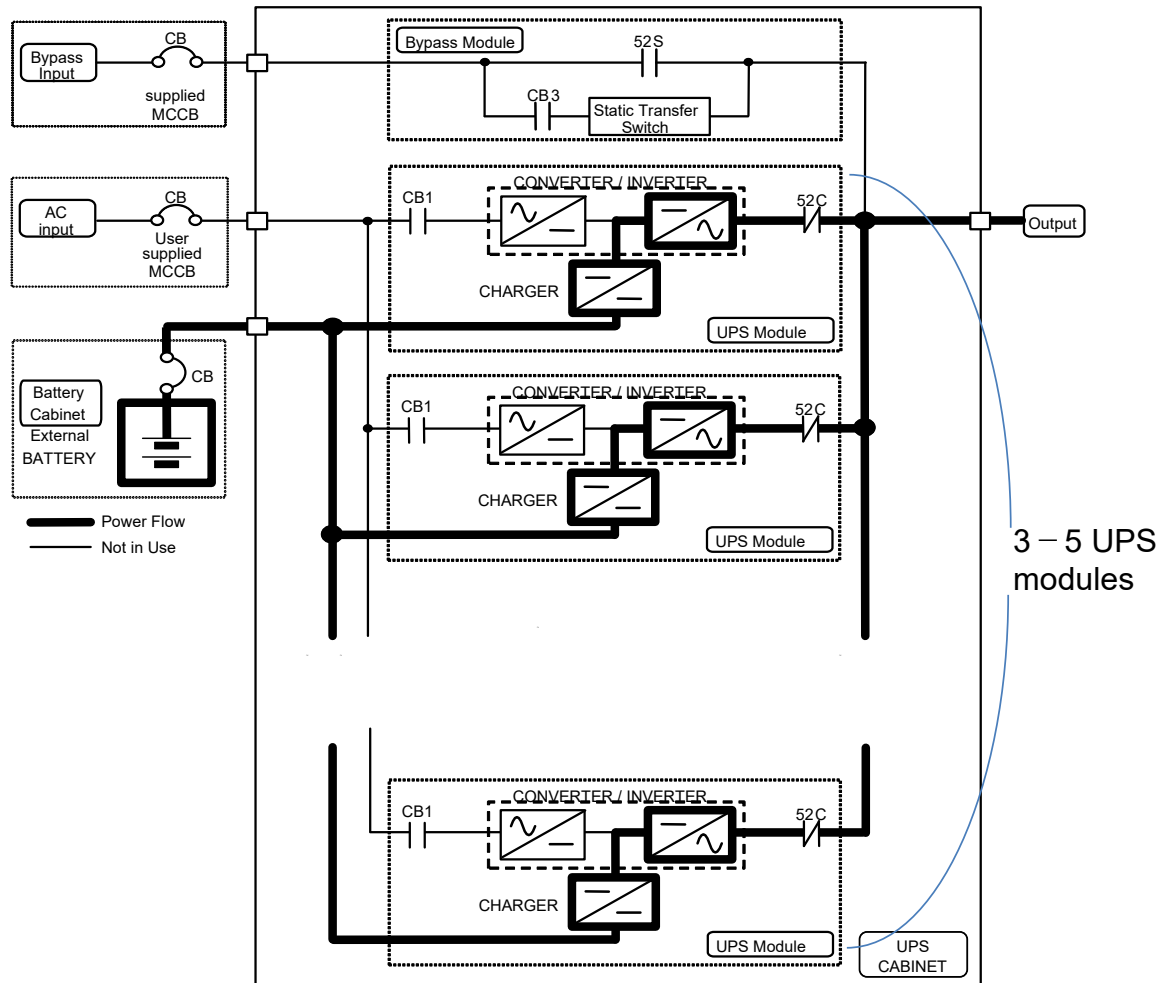
the Static Transfer Switch line through CB3 (herein after STS contactor CB3) supplies the power immediately, and then the Internal Bypass line through 52S supplies the power. In the event of a switching to the Bypass line, the power to the critical load will be uninterrupted. The purpose of this Internal Bypass line is to route power to the critical load while the UPS module is de-energized (converter and inverter), and during Start-up before the system is fully operational.

Each UPS internal static bypass line will equally share the power supplied to the critical load in the Parallel Operation if a cable length of bypass line is equal each other. For a MMS unable to equalize the cable length, additional reactors should be installed to compensate the difference in cable impedance.

In the event of a load overcurrent, the UPS transfers to bypass without interruption to the critical load. In the case of the Parallel Operation, all UPS will transfer to bypass without interruption to the critical load.

The internal control system determines the operation of the two paths, with the load powered from the inverter being the normal operation.



**C) Battery operation: Load Power supplied by UPS battery.**
**Figure 1.3 Single Line Diagram - Battery Operation**


Referring to Figure 1.3: In the event of AC input source failure or interruption, the UPS Converter(s)\* will de-energize and the UPS battery(s)\* will immediately discharge and supply DC power to the Inverter to maintain continuous AC power to the load. This operation will continue until:

- The battery capacity expires and the inverter turns off, or
- Input power is restored after which the converter will power the inverter and critical load and simultaneously recharge the batteries.

A fully charged battery will provide power for the specified time at the rated load, or longer, at a reduced load.

(s)\* : In the case of the Parallel Operation

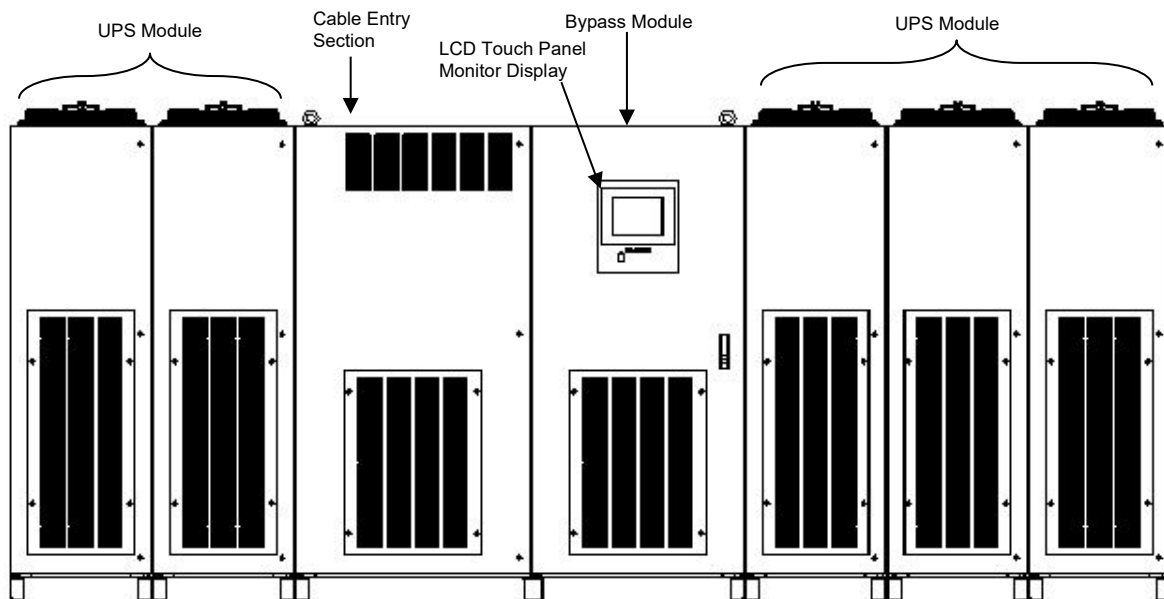
When power is restored after a low battery shutdown, the UPS converter(s)\* automatically restarts operation, the charger(s)\* recharges the batteries and the Inverter(s)\* is automatically restarted without operator intervention. Load is automatically assumed by the inverter without operator intervention.

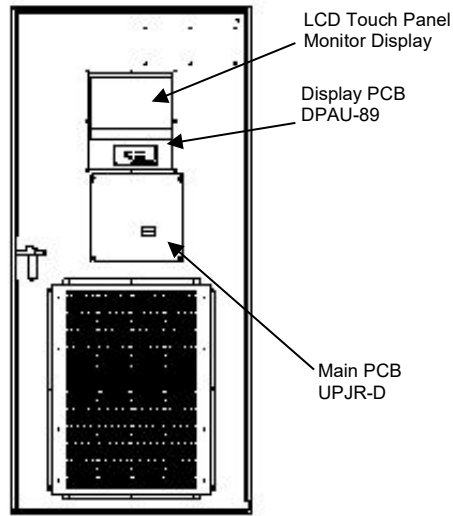
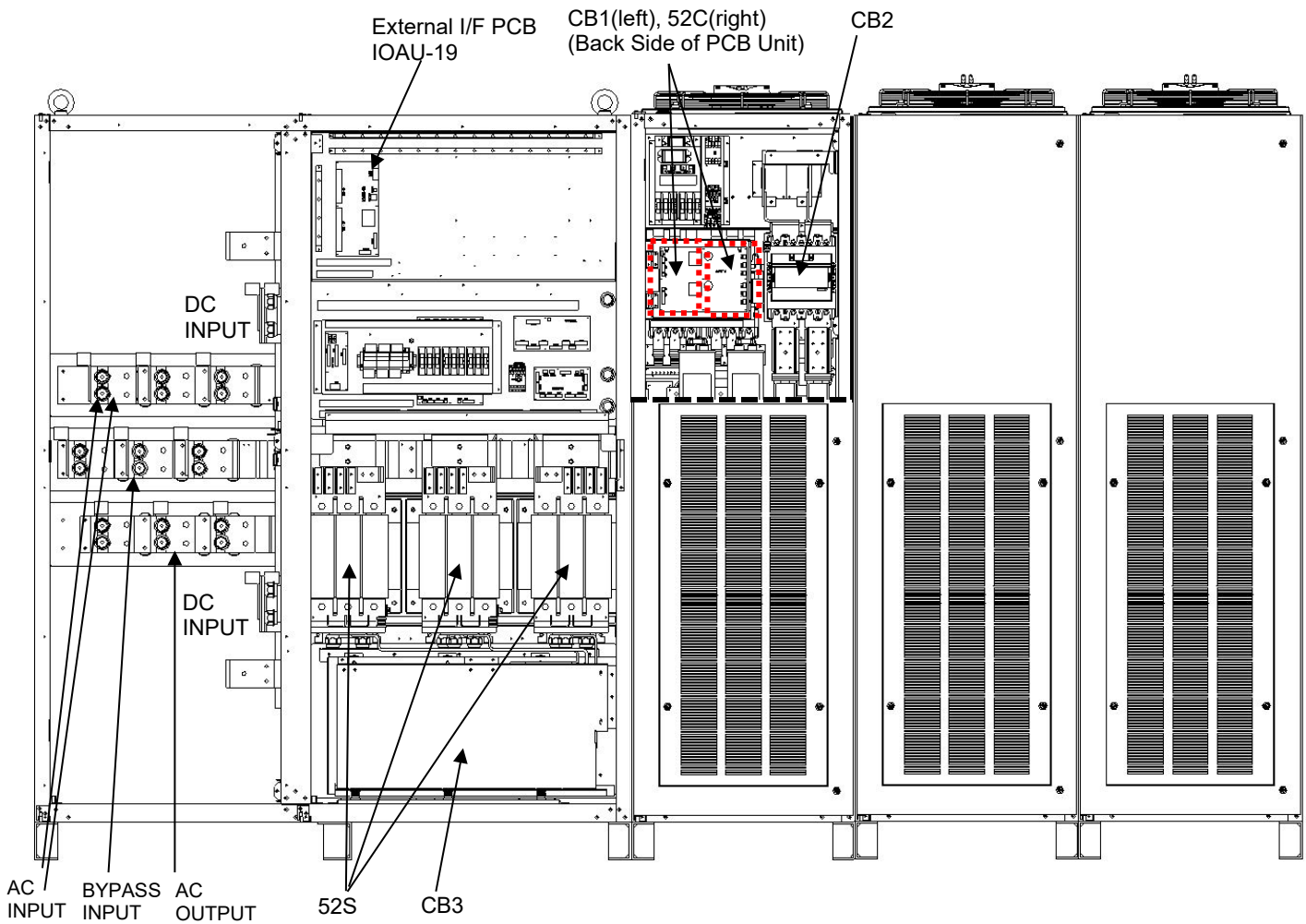
(s)\* : In the case of the Parallel Operation

The power drawn by the load is equally shared between all UPS regardless of the presence or absence of the UPS that is (are) in battery operation or not whenever the system is in the Parallel Operation.

**Figure 1.4** UPS Parts Location

1) UPS cabinet – Front View



**2) Backside of Bypass Module door**

**3) UPS cabinet – Front Inside View**


## 1.5 SPECIFICATIONS

The UPS nameplate displays the rated kVA as well as nominal voltages and currents. The nameplate is located on the backside of the Bypass Module door.

**Table 1.3** Power Specifications

Rated output Power	Input voltage 3 phase / 3 wire	Bypass input voltage 3 phase / 3 wire	Output voltage 3 phase / 3 wire
1200kVA / 1200kW	480V	480V	480V
1250kVA / 1250kW	480V	480V	480V
1500kVA / 1500kW	480V	480V	480V
1600kVA / 1600kW	480V	480V	480V
2000kVA / 2000kW	480V	480V	480V

**Table 1.4** UPS Cabinet Information

UPS [kVA]	Cable Entry	Width [in / mm]	Depth [in / mm]	Height [in / mm]	Weight [lb./ kg]	Heat Loss [kBTU / h]
1200	BOTTOM / TOP	133.9 / 3400	35.4 / 900	80.7 / 2050	7270 / 3300	135.4
1250	BOTTOM / TOP	133.9 / 3400	35.4 / 900	80.7 / 2050	7270 / 3300	141.0
1500	BOTTOM / TOP	169.3 / 4300	35.4 / 900	80.7 / 2050	9750 / 4423	163.7
1600	BOTTOM / TOP	169.3 / 4300	35.4 / 900	80.7 / 2050	9750 / 4423	174.6
2000	BOTTOM / TOP	192.9 / 4900	35.4 / 900	80.7 / 2050	11,470 / 5220	218.3

**Table 1.5** Detail of Specifications

Rated Output kVA	1200	1250	1500	1600	2000
Rated Output kW	1200	1250	1500	1600	2000
<b>AC INPUT</b>					
Configuration	3 phase, 3 wire				
Voltage	480 V +15% to -20%				
Frequency	60 Hz +/-10%				
Reflected Current THD	3% max. at 100% load				
<b>STATIC BYPASS INPUT</b>					
Configuration	3 phase, 3 wire				
Voltage	480 V +/-10%				
Frequency	60 Hz +/-5%				
<b>BATTERY</b>					
Type	Lead Acid				
Ride Through	Application Specific				
Nominal Voltage	480 Vdc				
Minimum Voltage	400 Vdc	420Vdc	400Vdc		
Maximum Voltage	600 Vdc				
Number of Cells	240				
<b>AC OUTPUT</b>					
Configuration	3 phase, 3 wire				
Voltage	480 V				
Voltage Stability	+/-1%				
Frequency	60 Hz				
Frequency Stability	+/-0.01% in free running mode				
Power Factor	1.0				
Power Factor Range	0.7 lagging to 0.8 leading				
Voltage THD	2% maximum THD at 100% Linear Load 5% maximum THD at 100% non-linear load				
Transient Response	+/-5% maximum at 100% load step +/-1% maximum at loss/return of AC power +/-5% maximum at load transfer to/from static bypass				
Transient Recovery	Less than 20ms				
Voltage Unbalance	+/-2% maximum at 100% unbalanced load				
Phase Displacement	+/-1deg. maximum at 100% load				
Inverter Overload	125% for 10 minutes 150% for 60 seconds	120% for 10 minutes 144% for 60 seconds	125% for 10 minutes 150% for 60 seconds		
System Overload (with bypass available)	500% for 1 cycle				
<b>ENVIRONMENTAL</b>					
Cooling	Forced Air				
Operating Temperature	32° F to 104° F ( 0° C to 40° C). Recommended : 68° F to 86° F ( 20° C to 30° C)				
Non-Operating & Storage Ambient Temperature	-4° F to 158° F (-20° C to 70° C).				
Relative Humidity	5% ~ 95% Non Condensing Recommended: 30% ~ 90% Non Condensing				
Altitude	0 to 6500 feet No Derating at 104° F (40° C)				
Location	Indoor (free from corrosive gases and dust)				
Paint Color	Munsell 5Y7/1 (Light gray smooth) or N1.5 (Black texture)				

**Table 1.6** Rating of Contactors, Breaker and Fuses

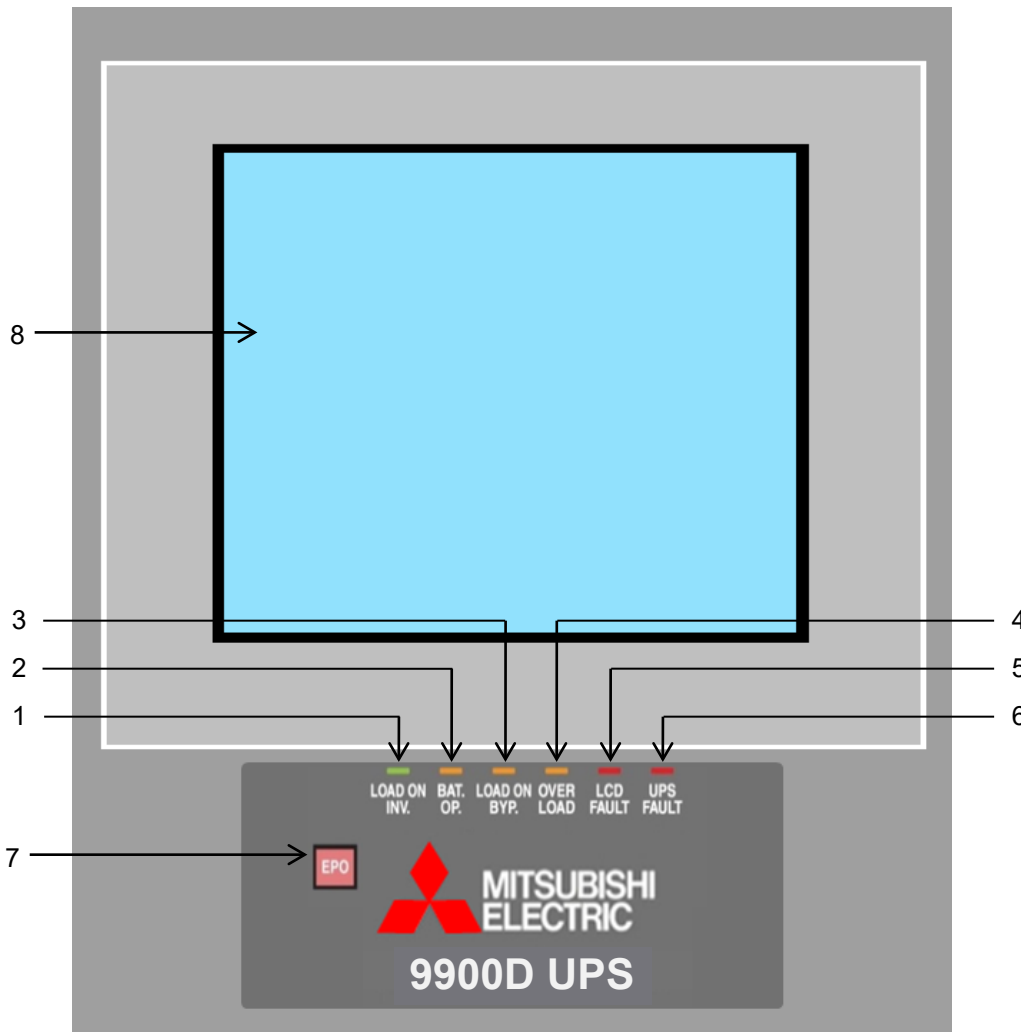
	IDENTIFI-CATION	APPLICATION	OUTPUT CAPACITY OF EQUIPMENT				
			1200kVA	1250kVA	1500kVA	1600kVA	2000kVA
			1200kW	1250kW	1500kW	1600kW	2000kW
Contactors	CB1	AC input contactor	<b>520A</b>				
	CB2P, CB2N	Battery contactor	<b>263A</b>				
	CB3	STS contactor	<b>704A</b> (12kA for 3 sec)				
	52C	Inverter output contactor	<b>520A</b>				
	52S	Bypass contactor	<b>1992A</b>		<b>2843A</b>		
	88RC	Control circuit contactor	<b>20A</b>				
Breakers	User supply	Battery disconnect breaker (Recommended)	<b>3000A</b>	<b>3000A</b>	<b>4000A</b>	<b>4000A</b>	<b>5000A</b>
	User supply	AC input breaker (Recommended)	<b>1600A</b>	<b>1600A</b>	<b>2000A</b>	<b>2500A</b>	<b>3000A</b>
	User supply	Bypass input breaker (Recommended)	<b>1600A</b>	<b>1600A</b>	<b>2000A</b>	<b>2000A</b>	<b>2500A</b>
	FP, FC, FN	DC fuse	<b>315A / 690V</b>				
	FBP, FBN	DC fuse	<b>1250A / 690V</b>				
	FBR1, FBR2, FBR3 FBR, FBS, FBT FBO1, FBO2, FBO3	Control power fuse	<b>12A / 600V</b>				
	FOA, FOB, FOC FIA, FIB FUA, FUB, FUC	Control power fuse	<b>12A / 600V</b>				
	(OPTION) FSU, FSV, FSW	Bypass input fuse	<b>2800A / 650V</b>		<b>3600A / 550V</b>		
(OPTION) FDU, FDV, FDW	Parallel control circuit fuse (optional)	<b>3A / 600V</b>					

\* Rating would be changed.

## 2.0 OPERATOR CONTROLS AND INDICATORS

The 9900D Series operator controls and indicators are located as follows (Bypass Module door exterior) :

**Figure 2.1** Operation/Display Panel (Front panel)



## 2.1 LED DISPLAY

- 1) **Load on inverter [ LOAD ON INVERTER ](green)**  
Illuminates when power is supplied from inverter to the critical load.  
(Indicates the state of inverter transfer switch "52C".)
- 2) **Battery operation [ BATTERY OP. ](yellow)**  
Illuminates when power is supplied from batteries following a power failure.
- 3) **Load on bypass [ LOAD ON BYPASS ](yellow)**  
Illuminates when power is supplied to load devices by static bypass.  
(Indicates the state of bypass transfer switch "52S".)
- 4) **Overload [ OVERLOAD ](yellow)**  
Illuminates in overload condition.
- 5) **LCD fault [ LCD FAULT ](red)**  
Illuminates when an error occurs.
- 6) **UPS fault [ UPS FAULT ](red) [Annunciator: intermittent or constant tones]**  
Illuminates when an error occurs in the system. In this case, the details of the error are indicated on the display panel.

## 2.2 EPO BUTTON (Emergency Power Off button) (7)

When activated, the Emergency Power Off (EPO) function shuts down the UPS module. The critical load will lose power and also shutdown. The EPO function can be performed both locally or remotely.

## 2.3 LIQUID CRYSTAL DISPLAY (8)

The Liquid Crystal Display (LCD) touch panel indicates power flow, measured values, operational guidance, data records and error messages. The LCD panel has a back-light which facilitates viewing in different ambient lighting conditions. The LCD will automatically clear and turn off, if the screen is not activated within 3 minute period. The LCD is turned back on when it is touched again. Every error indicator will be cleared 24 hours after the event and can be reproduced by pressing any key on the panel.



### 2.3.1 MENU

#### A) MAIN MENU (Figure 2.2)

The LCD panel indicates power flow and measured values, while also operating the start/stop function. The LCD panel also allows the user to verify the status and operation of the UPS Module.

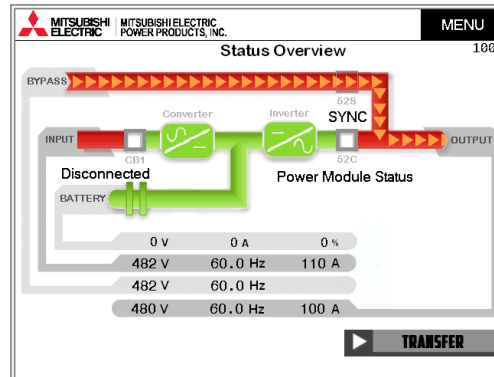


Figure 2.2 Main Screen

The following will be displayed when the TRANSFER key on the MAIN MENU is pressed:

#### 1) Start/Stop Operation (Figure 2.3)

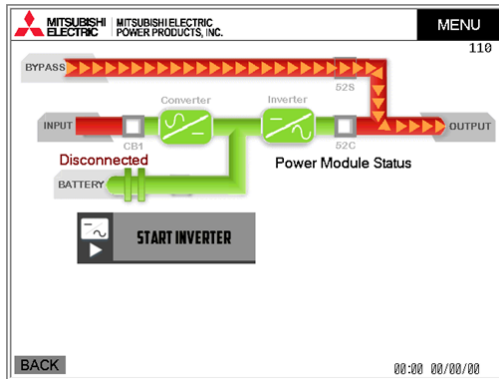
The display indicates the Start/Stop operation for the UPS system. If this operation is PIN protected, the user is required to enter the security PIN before the screen can be accessed.

When in remote mode, the message "REMOTE operating mode" will appear on this Screen. The user cannot operate the start and stop functions without changing the setup from remote mode to local mode.

When bypass voltage is abnormal, the message "Bypass voltage abnormal" will appear.

- **TRANSFER TO INVERTER (SMS):** When the bypass voltage is abnormal, the LCD asks the operator if an interrupted transfer is acceptable (Load may be lost).

- **TRANSFER TO BYPASS (SMS):** When the bypass voltage is abnormal, the user cannot transfer from inverter to bypass line.

**Figure 2.3(a)\* Start/Stop Operation**


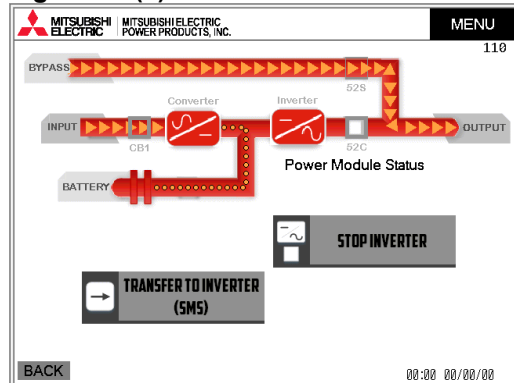
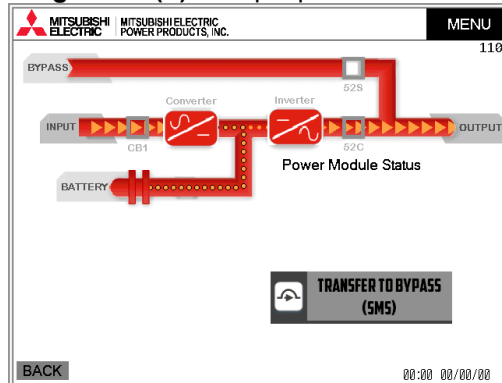
\*Meaning of the icons in SMS (Single Modular System)

**START INVERTER:** UPS Module Startup

**STOP INVERTER:** UPS Module Stop

**TRANSFER TO INVERTER (SMS):** Output Transfer from Bypass Line to Inverter

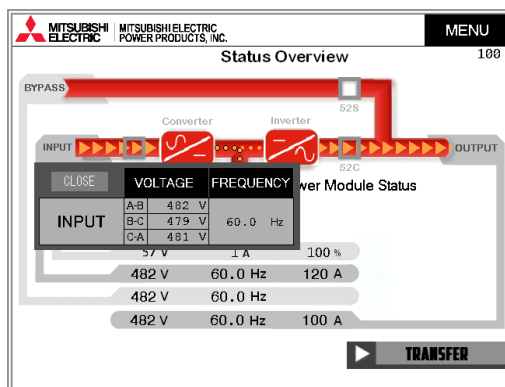
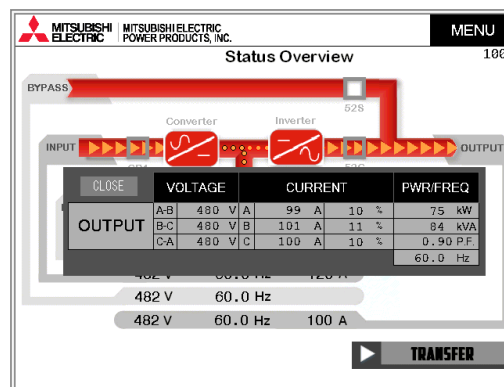
**TRANSFER TO BYPASS (SMS):** Output Transfer from Inverter to Bypass Line

**Figure 2.3(c) Transfer to Inverter**

**Figure 2.3(d) Stop Operation**


Follow Start/Stop operation guidance accordingly.

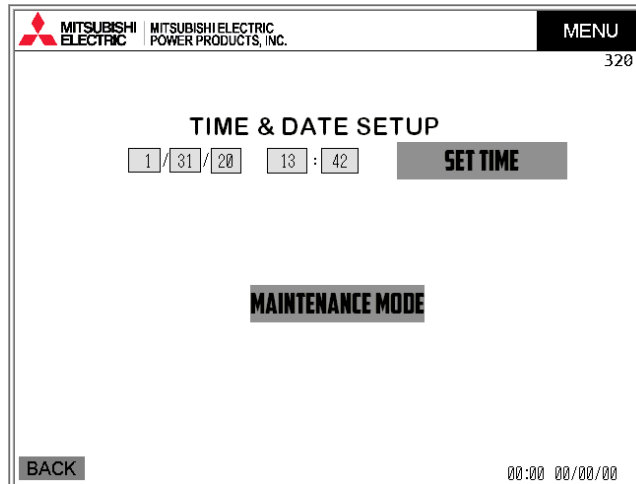
## B) MEASUREMENT MENU (Figure 2.4)

This screen shows details of measured values. Input and Output values are displayed.

**Figure 2.4(a) Input Values**

**Figure 2.4(b) Output Values**


**C) OPERATION MENU (Figure 2.5)**

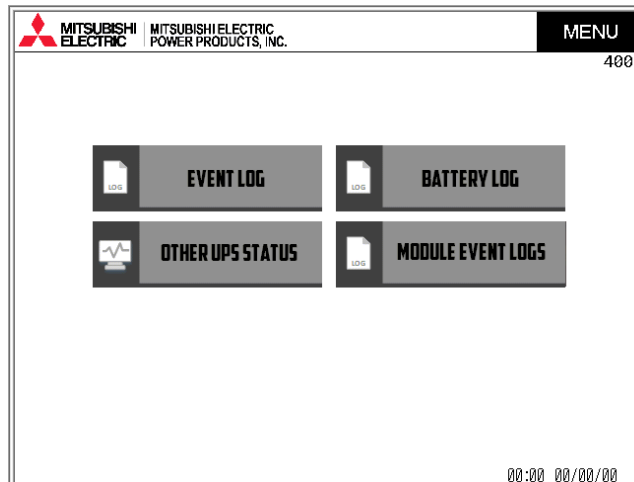
This screen prompts the user to select: whether the start & stop operation will be performed by local or remote operation; date & time adjustment; battery equalizing charge. The battery equalizing charge operation key will appear when battery equalizing charge is set up (Setup is based on battery type).

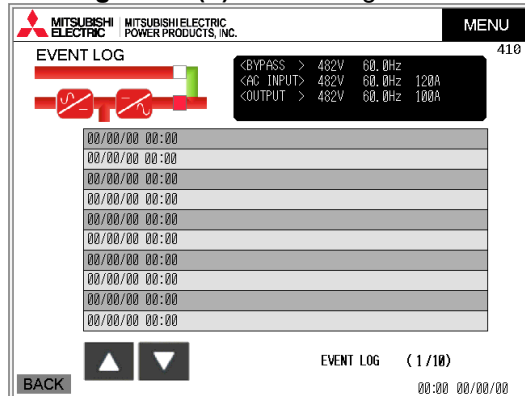
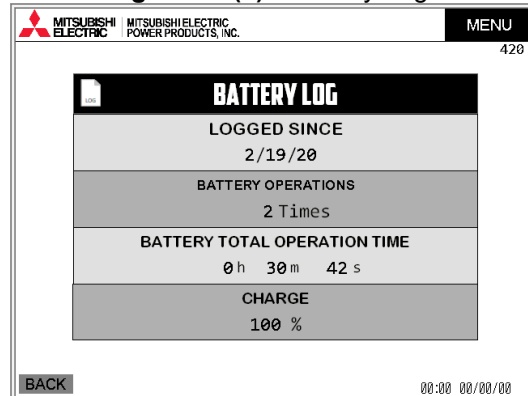
**Figure 2.5 Remote/Local Operation or Date & Time Adjustment Select**

**D) LOG MENU (Figure 2.6)**

This LOG MENU displays two Touch icons in EVENT LOG and BATTERY LOG.

Pressing the EVENT LOG icon, up to 100 condition/operation records will be displayed. Press ▲ or ▼ button for page turning.

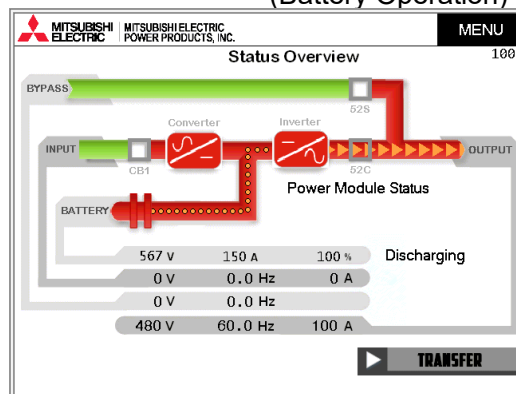
Pressing the BATTERY LOG icon, Number of battery operations and Summed battery operation time are displayed.

**Figure 2.6(a) Log Menu**


**Figure 2.6(b) Event Log**

**Figure 2.6(c) Battery Log**


### 2.3.2 INPUT POWER FAILURE (Figure 2.7)

During an Input Power Failure, the UPS inverter will be powered by the UPS batteries. The following will be displayed on the main and measurement screen (Indication of battery operation and remaining battery life).

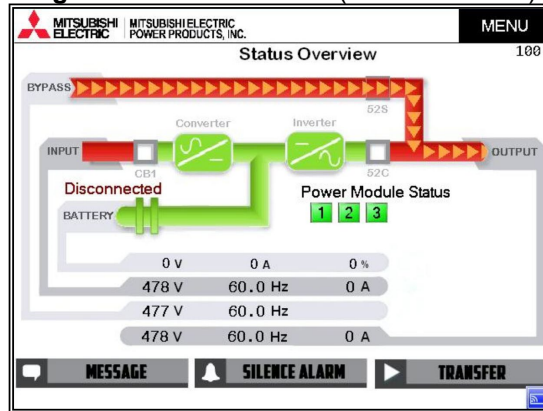
**Figure 2.7 Main Screen (Battery Operation)**


The LCD will display a battery low voltage message when the battery capacity is near depletion. The End of Battery Discharge announcement is displayed when the battery end voltage is reached. At this time, the inverter will perform an electronic shutdown to prevent battery loss of life from extreme deep discharge conditions. When the input power is restored, the inverter will automatically restart to power the load, and the batteries will be simultaneously recharged. The End of Battery announcement is shown at the bottom of the screen.

### 2.3.3 FAULT INDICATION (Figure 2.8)

“MESSAGE” and “SILENCE ALARM” icons will appear on the main menu when UPS failure condition has occurred.

**Figure 2.8** Main Screen (Fault Indication)

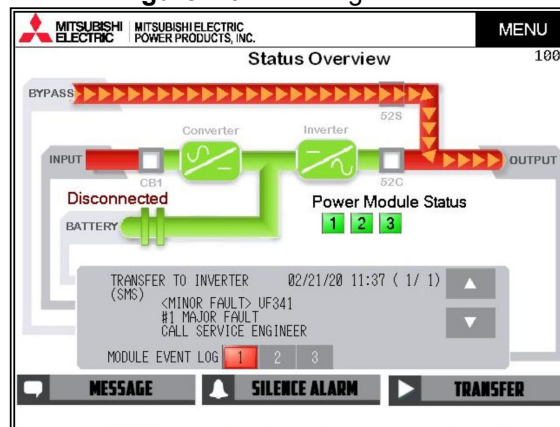


The following will be displayed when the MESSAGE icon on the main menu is pressed.

#### 1) MESSAGE (Figure 2.9)

The display shows a fault code, the description of the fault and a guidance of what action is to be taken by the user. A maximum of 10 faults is displayed at one time. If an input power failure occurs during a fault condition, the fault indication and input power failure announcement are alternatively displayed at 5 second intervals.

**Figure 2.9** Message screen



#### 2) SILENCE ALARM

This icon will appear when a failure occurs. The audible alarm (announcing the failure) can be silenced by pressing this icon.

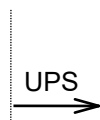
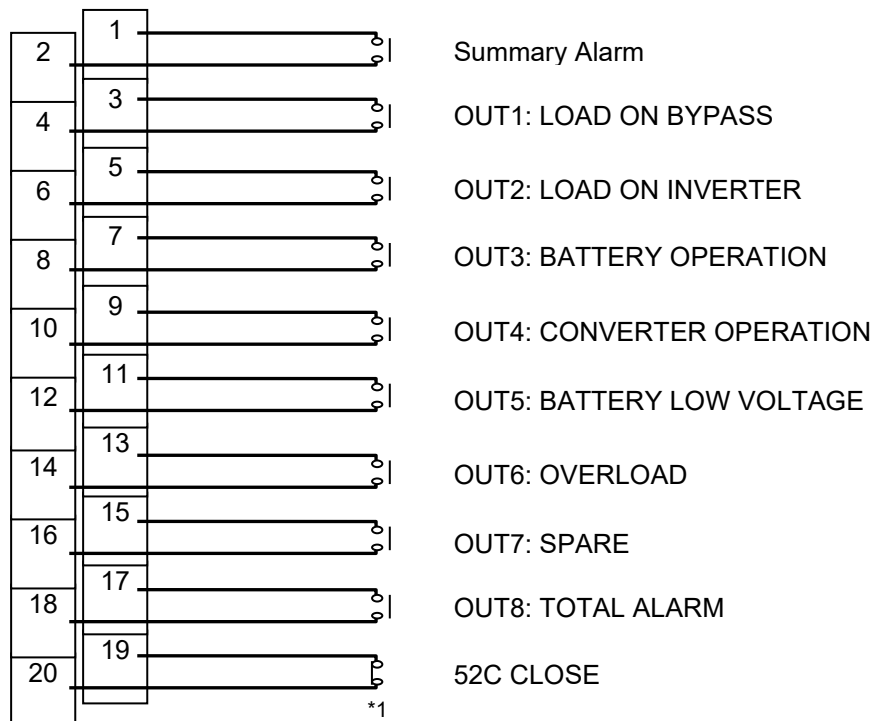
## 2.4 EXTERNAL SIGNAL TERMINAL BLOCK

The UPS is equipped with a series of input/output terminals for external annunciation of alarms and for remote access of certain UPS functions. The layout of terminals is shown in Figure 2.10 with a functional description of the input/output port presented. OUT1 to OUT8 are user programmable, but are factory default set being also shown in Figure 2.10.

Adding same external I/F PCB "IOAU-19", doubling signal outputs is applicable for OUT1 to OUT8.

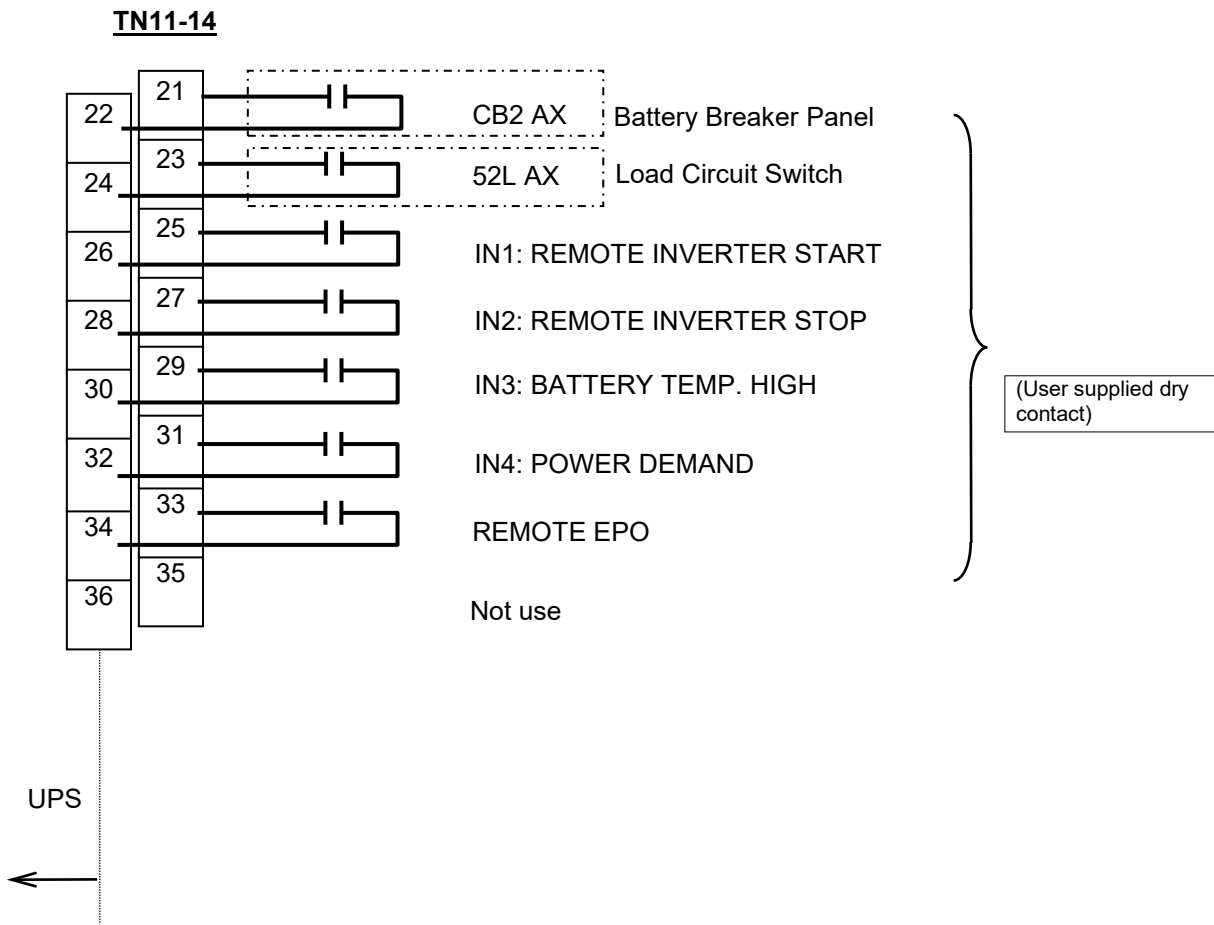
**Figure 2.10(a)** External Signal Terminal Block TN21-25 (NEC Class2)

### TN21-25



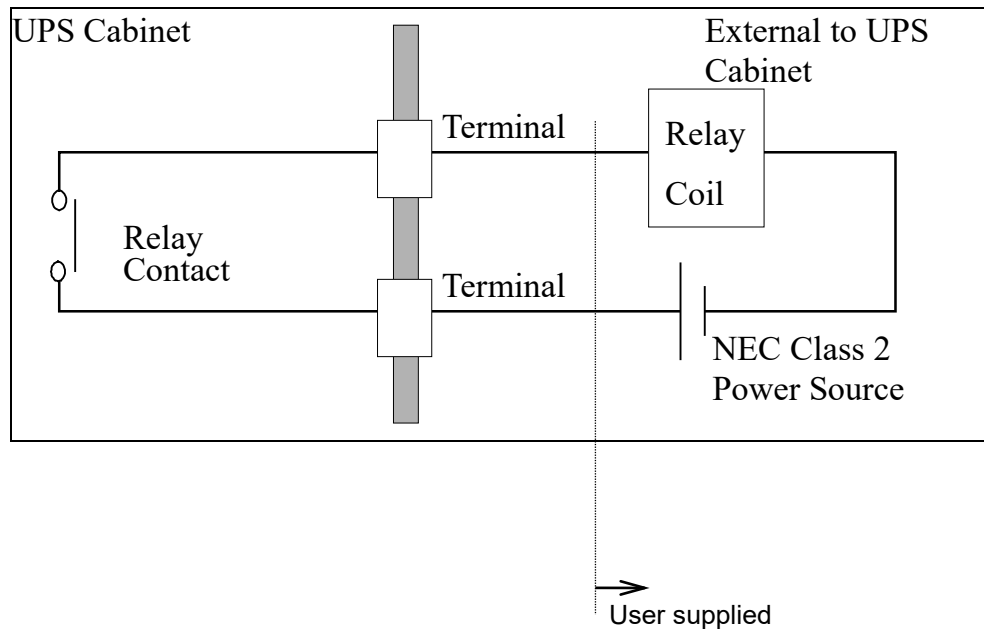
\*1 Relay contactor (52C close): Normally Closed

**Figure 2.10(b)** External Signal Terminal Block TN11-14 (NEC Class2)



**A) Output Contacts (for external alarm annunciation)**

Output contacts consist of form "A" dry type contacts. Rated capacity of all output contacts is NEC Class2 (30Vdc/1Adc). All dry contacts should be operated at their rated values or lower. Figure 2.11 illustrates a typical installation. The external relay can also be a lamp, LED, computer, etc.

**Figure 2.11 Control Wiring for External Contacts**

**Details of output alarm contacts : TN21-25**
**Terminals 1 to 2 "Summary Alarm" contact**

Activated when a major fault has occurred with the system.

**Terminals 3 to 4 "Load on Bypass" contact (OUT1)**

Activated when the power is supplied from the static bypass input.

**Terminals 5 to 6 "Load on Inverter" contact (OUT2)**

Activated when the power is supplied by the inverter.

**Terminals 7 to 8 "Battery Operation" contact (OUT3)**

Activated when the battery is operating following an AC power failure.

**Terminals 9 to 10 "Converter Operation" contact (OUT4)**

Activated when the converter is operating.

**Terminals 11 to 12 "Battery Low Voltage 2" contact (OUT5)**

Activated when the battery voltage drops below discharge end voltage level during inverter operation (i.e. During AC fail condition).

**Terminals 13 to 14 "Overload" contact (OUT6)**

Activated when an overload has occurred to the system.

**Terminals 15 to 16 "Spare" contact (OUT7)**



**Terminals 17 to 18 "Total Alarm" contact (OUT8)**

Activated during major fault, minor fault and alarm events.

**Terminals 19 to 20 "52C Close" contact**

Activated when the inverter output contactor 52C has closed.

The UPS is equipped with a selectable output contact feature, and above items are the default settings. Table 2.1 shows the selectable items for output contacts.

**Table 2.1 Selectable Items for Output Contacts**

No.	Output Item	Default
0	NONE	
1	TOTAL ALARM	OUT8
2	MINOR FAULT	
3	ALARM	
4	AC INPUT ABNORMAL	
5	BYPASS ABNORMAL	
6	BATTERY ABNORMAL	
7	BATTERY LOW VOL.1	
8	BATTERY LOW VOL.2	OUT5
9	BATTERY DEPLETION	
10	OVERLOAD	OUT6
11	OVERLOAD PREALARM	
12	FAULT GROUP 1	
13	FAULT GROUP 2	
14	BYPS.SYNCHRONOUS	
15	BYPS.ASYNCHRONOUS	
16	REMOTE OPE.ENABLE	
17	LOAD ON INVERTER	OUT2
18	LOAD ON BYPASS	OUT1
19	LOAD ON AC	
20	BATTERY OPERATION	OUT3
21	CONVERTER OPERATION	OUT4
22	INVERTER OPERATION	
23	CB1 CLOSE	
24	CB2 CLOSE	
25	52S CLOSE	
26	POWER DEMAND ON	
27	EQUALIZING CHARGE	
28	ANOTHER BUS SYNC.OK	
29	SPARE 29	
30	SPARE 30	
31	SPARE 31	


**NOTE**

Contact MITSUBISHI ELECTRIC POWER PRODUCTS, INC for Detailed information.

**B) Input Contacts (for remote access of UPS)**

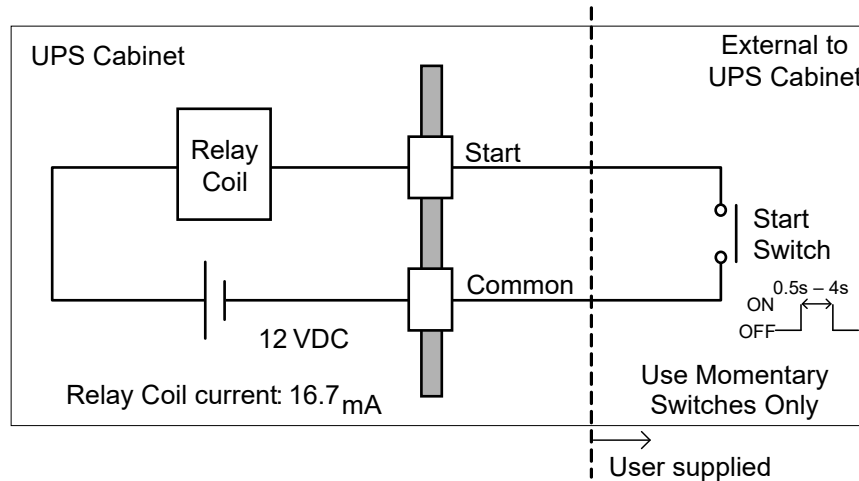
External contacts are provided by the user of the UPS system. Terminal voltage at the UPS is 12Vdc. Provide external dry contact accordingly.



**Do not apply voltages to remote access input terminals.  
Damage to UPS may result.**

Refer to Figure 2.12 for a typical wiring configuration. Although this figure applies to the remote start/stop terminals, the same wiring arrangement is used for emergency stop; power demand; and battery temperature high.

**Figure 2.12** Remote "Start" Contact Connections



**Details of input contacts for remote access : TN11-14****Terminals 25 to 26 Remote "Inverter Start" input terminal (IN1)**

Used to start inverter from a remote location. UPS must be programmed for remote operation. Refer to Operations Menu for procedure.

**Terminals 27 to 28 Remote "Inverter Stop" input terminal (IN2)**

Used to stop inverter from a remote location. UPS must be programmed for remote operation. Refer to Operations Menu for procedure.

**Terminals 29 to 30 "Battery Temp. High" contact input (IN3)**

Input fed by a thermocouple that monitors battery temperature. The converter float voltage level is reduced for battery over-temperature conditions. External thermocouple is user supplied

**Terminals 31 to 32 "Power Demand" Command contact input (IN4)**

This contact is used to control the input power. Power demand is turned ON when the contact is closed, and power demand is turned OFF when the contact is open.

**Terminals 33 to 34 "Remote EPO" contact input**

Used to perform a remote UPS Emergency Power Off (EPO).

**The load will be dropped.**

The UPS is equipped with a selectable input contact item. The above items are the default settings. Table 2.2 shows the selectable items for input contacts.

**Table 2.2 Selectable Items for Input Contacts**

No.	Input Item	Default
0	NONE	
1	REMOTE START	IN1
2	REMOTE STOP	IN2
3	POWER DEMAND 1	IN4
4	POWER DEMAND 2	
5	BATTERY LIQUID LOW	
6	BATTERY TEMP.ABNORMAL	IN3
7	GENERATOR OPERATION	
8	ASYNCHRONOUS	
9	ANOTHER BUS SYNC.	
10	REMOTE INVERTER(MMS)	
11	REMOTE BYPASS(MMS)	
12	EXT.BYP dV STR	
13	USE IB LIMIT 2	
14	CHARGER STOP	
15	EXTERNAL ALARM	
16	CB2 EX	
17	CHARGE DEVICE ERR	
18	CONVERTER OPE. PROHIBITION	
19	REMOTE MOD.START	
20	REMOTE MOD.STOP	
21	SPARE 21	
22	SPARE 22	
23	SPARE 23	
24	SPARE 24	
25	SPARE 25	
26	SPARE 26	
27	SPARE 27	
28	SPARE 28	
29	SPARE 29	
30	SPARE 30	
31	TRACE TRIGGER	



**NOTE**

Contact **MITSUBISHI ELECTRIC POWER PRODUCTS, INC** for Detailed information.



**CAUTION**

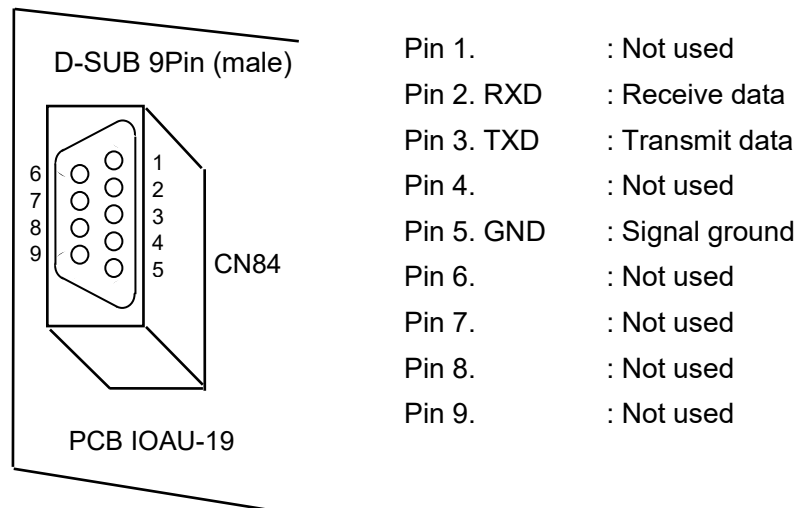
In all cases, a switch having a protective cover is recommended in order to reduce the possibility of accidental operation.

## 2.5 EXTERNAL COMMUNICATION CONNECTOR

This is an RS232C port for “DiamondLink”<sup>\*</sup> monitoring software.

The layout of connector is shown in Figure 2.13.

**Figure 2.13** External Communication Connector (NEC Class2)



\* Consult MITSUBISHI ELECTRIC POWER PRODUCTS, INC for details on “DiamondLink” monitoring software and its capabilities.

### 3.0 INSTALLATION AND STORAGE

#### 3.1 STORAGE AND HANDLING

The unit shall be stored in the recommended environmental conditions listed in Table 1.5.



**DO NOT STACK UPS CABINETS**

**PROHIBIT**

Cabinets shall be handled using a forklift or pallet jack of sufficient lifting capacity or lifted by the lifting lugs. Refer to Sales Drawing for lifting lug locations.

UPS cabinets shall only be lifted with a forklift or pallet jack of sufficient lifting capacity from the sides stated on the shipping box. Refer to Figure 3.1 and Figure 3.2.

**Figure 3.1** Statement on the sides of the shipping box that can be lifted with a forklift.

**USE FORK LIFT  
THIS SIDE ONLY**

**Figure 3.2** Statement on the sides of the shipping box that cannot be lifted with a forklift.

**\*WARNING\*  
DO NOT LIFT  
FROM THIS SIDE**

The center of gravity will be identified with a stamp on the outside of the shipping box and with a sticker on the sides and back of the UPS cabinet. Refer to Figure 3.3.

**Figure 3.3** Center of Gravity marked on the cardboard shipping box (Left) and Center of Gravity sticker on the sides and back of the UPS cabinet (Right)



**Do NOT transport in a horizontal position. Cabinets shall be maintained upright within +/- 15° of the vertical during handling. Violation of this may void warranty.**



**Do not transport or lift UPS modules when they are completely or partially assembled with other UPS modules. Units shall be handled by their individual shipping sections.**



**Do not drop UPS cabinets.**

### **3.2 INSTALLATION PROCEDURE**



**Cleaning of unit before and after installation shall be done only by authorized MEPPi personnel**

### **FOUNDATION REQUIREMENTS**

A level and rigid foundation is essential to minimize vibrations and maintain proper alignment of the equipment. The foundations should be either a reinforced concrete floor, which is preferred, or a steel substructure.

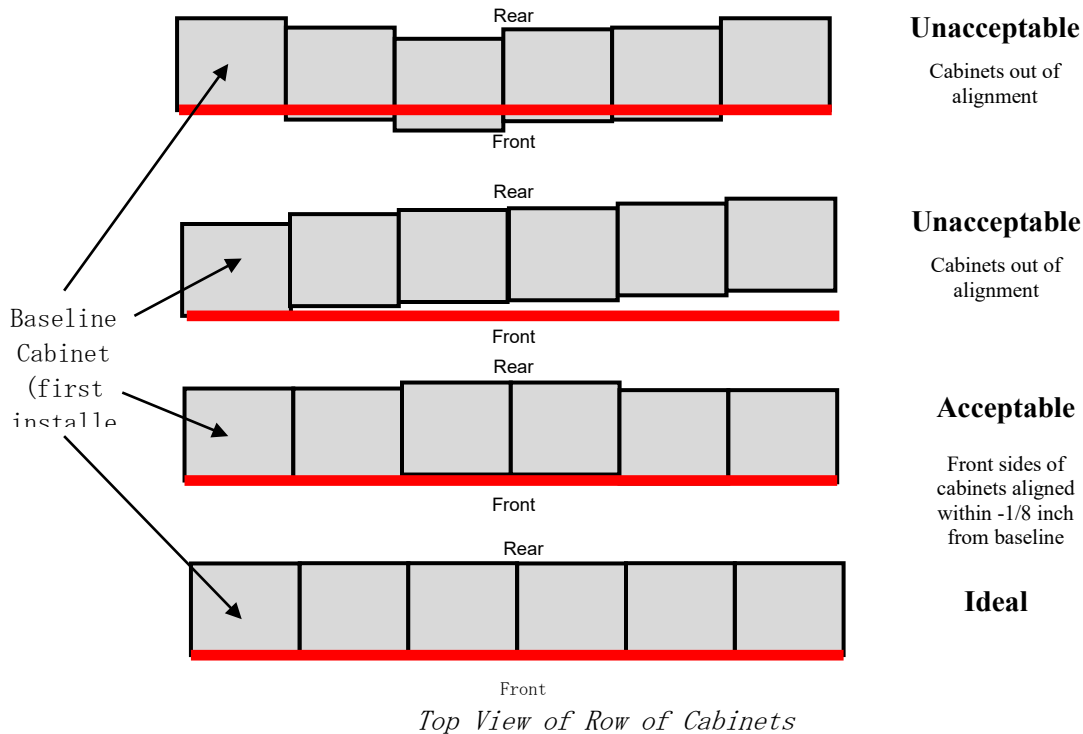
Foundations, including poured foundations and supporting framework, shall be level. To verify, measure levelness over 4-foot (minimum) measurements. Level can be verified if a shim with a thickness no

greater than 1/16 inch can be placed under one edge of the level to attain a level reading.

## ALIGNMENT

Equipment shall be installed so that it is in alignment. Alignment of UPS sections shall be ensured *after* sections are fully anchored and *before* sections are bolted together. There shall be at least one point of contact between each cabinet and any gaps between cabinet sides shall not exceed 1/8 inch. Refer to Figure 3.1 for appropriate alignment.

**Figure 3.4** Examples of acceptable and unacceptable alignment



## CABINET LEVEL

All cabinets shall be level as measured left to right, front to back, and in any diagonal direction on the top of each cabinet. This should be verified across 4-foot (minimum) measurements.

The front side of each cabinet shall be plumb to within  $\pm 1/8$  inch. Verify that the front sides of the cabinets (excluding the doors) are plumb  $\pm 1/8$  inch over the entire height of the cabinet.

## CABINET ANCHORING



All cabinets shall be securely anchored to the foundation with bolts or anchoring lugs. It is the responsibility of the customer to size such anchoring. All mounting holes and the correct sizes of mounting hardware and fasteners shall be used. Other means of anchoring the cabinets (e.g. welding, adhesives, etc.) shall not be used without prior approval from Mitsubishi Electric.

### CONTACT WITH FOUNDATION

The cabinet mounting shall be inspected to ensure that the cabinets are resting solidly on the foundation by inserting a feeler gauge no thicker than 0.005 inches (0.127 mm) between the foundation and all base channel. If the feeler gauge cannot be inserted within 2 inches of the edge of each mounting hole, the cabinets are resting solidly on the foundation. If the feeler gauge can be inserted, steel shims shall be inserted within 2 inches of each side of every base channel mounting hole to maintain contact between the cabinet and foundation at all points. Refer to Figure 3.5 for shim contact around the mounting holes on the base channel.

**Figure 3.5** Shim contact around mounting holes on the base channel. (Bottom View)



### STEEL SHIMS

Use smallest number of shims possible, but no more than four (4). Shims shall be flat and straight, free from burrs, slag, or dents. If shims are bent, damaged, rusty, or otherwise deformed, they shall not be used. Shims shall be able to bear the weight of the supported item without deforming or becoming thinner over time. Always use the thickest shims possible to minimize number of shims used. Before reusing shim stacks, they should either be cleaned or new shims should be used.

### UNIT WEIGHT AND CLEARANCES

**A) Note the load tolerance of the floor**

Refer to Table 3.1 for list of UPS weights.

**Table 3.1** List of UPS Weights

UPS Capacity (kVA)	1200	1250	1500	1600	2000
Weight (lb.)	7270	7270	9750	9750	11,470

**B) Minimum clearance required for ventilation**

Right side ..... 25 mm (1 inch) (not required when sidecars are used)

Left side ..... 25 mm (1 inch) (not required when sidecars are used)  
 Back side ..... 0.0 mm (0 inch)  
 Top side ..... 610 mm (24 inches) (for air flow)

**C) Space requirement for routine maintenance**

Allow for the following space at the time of installation.

Front ..... 1075 mm (42 inches)  
 Sides ..... 0.0 mm (0 inch)  
 Back side ..... 0.0 mm (0 inch)  
 Top side ..... 610 mm (24 inches)

**EXTERNAL BATTERY SUPPLY**

Please refer to the following when installing and maintaining batteries:



1. The customer shall refer to the battery manufacturer's installation manual for battery installation and maintenance instructions.
2. The maximum permitted fault current from the remote battery supply, and the DC voltage rating of the battery supply over-current protective device are shown in Table 3.3.

**Table 3.2** Maximum Permitted Fault Current

<b>UPS Capacity (kVA)</b>	<b>DC Voltage Rating (V)</b>	<b>Maximum Fault Current Permitted (A)</b>
1200	480	25,000
1250	480	25,000
1500	480	25,000
1600	480	25,000
2000	480	25,000

### 3.3 PROCEDURE FOR CABLE CONNECTIONS

**CAUTION**

All hardware shall be accounted for during installation. Failure to account for given hardware may void warranty.

1. Identify the input/output power terminal blocks as shown in Figure 3.6.
2. Connect the internal control wire and power wire.
  - (1) Control wire interconnections
    1. Battery CB ON Auxiliary to terminal TN11-14-21,22 of external I/F PCB IOAU-19.
  - (2) Power wire (AC input, Bypass input, AC output) interconnections
    - a.) From user's distribution panel
      1. X1 (A-phase) to A bus bar in UPS
      2. X2 (B-phase) to B bus bar in UPS
      3. X3 (C-phase) to C bus bar in UPS
    - b.) DC Input to UPS
      1. Positive cable to BP bus bar in UPS
      2. Negative cable to BN bus bar in UPS

**CAUTION**

**After the completion of the input power cables connection: With a phase rotation meter, check that the phase rotation of the AC Input power terminals A, B and C as well as the Bypass Input power terminals A40, B40 and C40 are correct. The proper phase rotation is clockwise  
A → B → C.**

3. Connect the grounding conductor from the input service entrance to the UPS Grounding Bar (E).
4. Two (2) sources feeding the UPS:
  - (1) Connect the AC input power cables from the input service entrance to the AC input power terminals, identified as A, B, C in Figure 3.6. Input cables shall be sized for an ampere rating larger than the maximum input drawn by the converter. (Refer to equipment nameplate for current ratings.) Confirm that an external bypass input circuit breaker (MCCB) is installed (refer to WARNING 4, page 1-5). Connect the bypass input power cables from the input service entrance to the bypass input power terminals, identified as A40, B40 and C40 in Figures 3.6 to 3.7. Bypass input cables shall be sized for an ampere rating larger than the maximum output current capacity of the UPS. Refer to Table 3.3 for recommended cable sizes.

(2) Connect the external signal terminal block as desired. Refer to section 2.4 and Figure 2.10 for functional description. 14 AWG, or less, shielded conductor is recommended.

5. One (1) source feeding the UPS:

(1) Confirm that an external input circuit breaker sized to protect both the AC input and the bypass line is installed. (Refer to equipment nameplate for current ratings.) Connect the bypass input power cables from the input service entrance to the bypass input power terminals, identified as A40, B40 and C40 in Figures 3.6 to 3.7. Input cables shall be sized for an ampere rating larger than the maximum current capacity of the UPS. Refer to Table 3.3 for recommended cable sizes.

(2) Using adequately sized conductors and referring to the appropriate figure identified in Figures 3.6 to 3.7, connect jumper bypass terminals A40, B40, C40 to AC input power terminals A, B, C as identified in Figures 3.6 to 3.7.

(3) Connect the external signal terminal block as desired. Refer to section 2.4 and Figure 2.10 for functional description. 14 AWG, or less, shielded conductor is recommended.



**CAUTION**

**It is recommended that compression lugs be used to fasten all input/output power cables.**

6. Procedure for Cable Connections for Parallel Operation System

(1) Confirm the number of units to be connected in parallel. Identify the input/output power terminal blocks and control wire connections for parallel operation systems as shown in the appropriate Figures 3.9 and 3.10.

(2) Connect the external control wire and power wire.

a.) Control wire connections

Parallel configuration wiring (Refer to figure 3.10.)

- 52L control signal from Critical Load Cabinet (CLC) to UPS-n IOAU-19 (TN11-14-23, 24).
- Parallel control signal for TLAIN, TLAOUT, TLBIN, TLBOUT, CA1IN, CA1OUT, DIAIN, DIAOUT, DIBIN, DIBOUT as shown in Fig. 3.10.

b.) Power wire connections

From UPS AC Output Terminals to Critical Load Cabinet (CLC) (Refer to Figure 3.9 and 3.10.)

**Table 3.3** Recommended Cable Sizes

kVA Capacity	Input Voltage	Output Voltage	Input Side Cable Size	Output Side Cable Size	Bypass Side Cable Size	DC Input Side Cable Size
1200kVA	480V	480V	5 x 500MCM	5 x 500MCM	5 x 500MCM	9 x 500MCM
1250kVA	480V	480V	5 x 500MCM	5 x 500MCM	5 x 500MCM	9 x 500MCM
1500kVA	480V	480V	7 x 500MCM	7 x 500MCM	7 x 500MCM	11 x 500MCM
1600kVA	480V	480V	7 x 500MCM	7 x 500MCM	7 x 500MCM	11 x 500MCM
2000kVA	480V	480V	9 x 500MCM	8 x 500MCM	8 x 500MCM	14 x 500MCM

\*1 – Use 75 degree C copper wire.

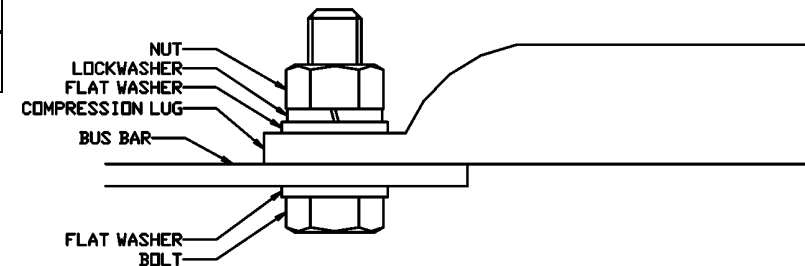
\*2 - The cables shall be selected to be equal or larger to the sizes listed in the table.

\*3 - Voltage drop across power cables not to exceed 2% of nominal source voltage.

\*4 - Allowable ampere-capacities based on copper conductors with 75 degree C. insulation at ambient temperature of 40 degree C.

**Table 3.4** Recommended Hardware

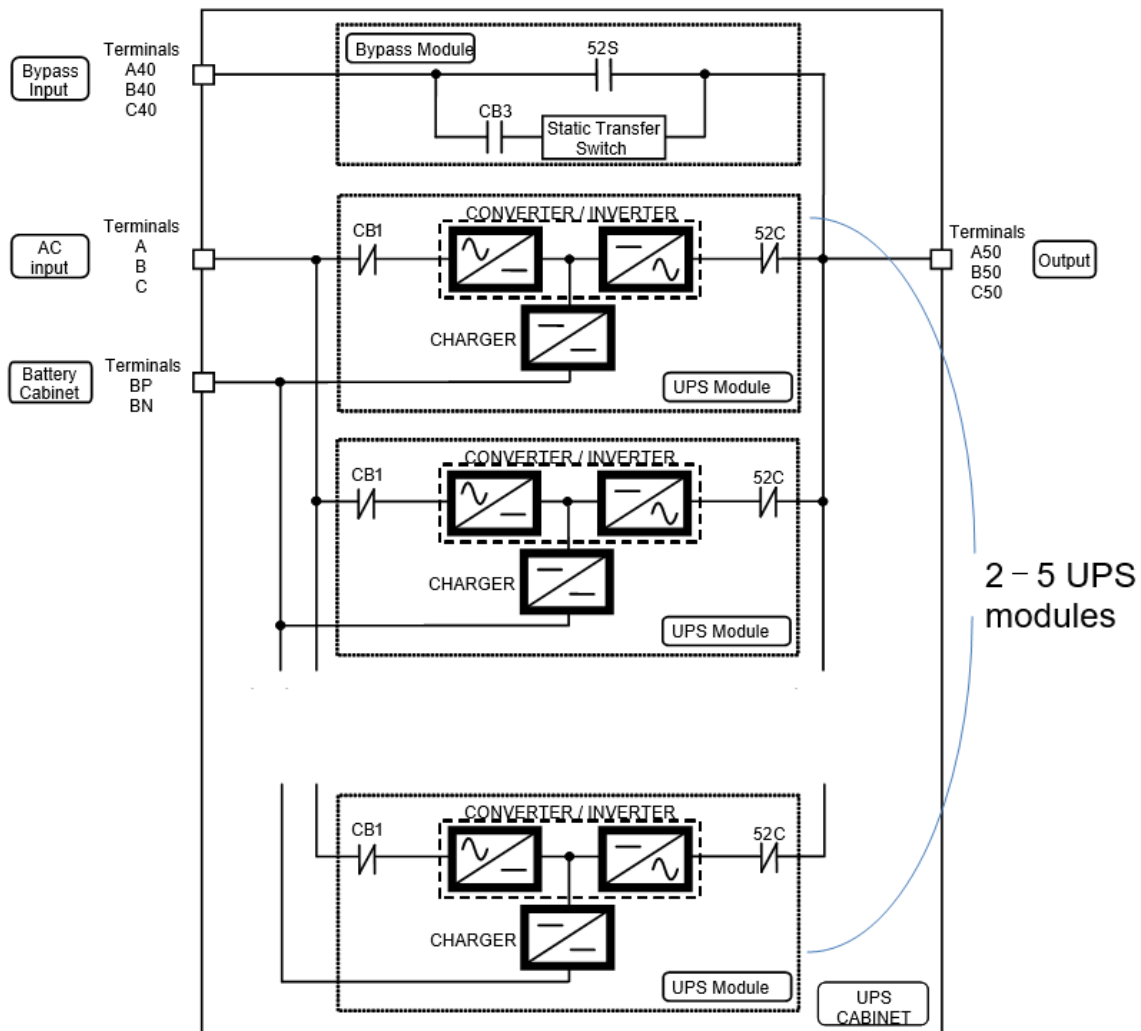
Bolt size	Flat washer size	Split lockwasher size	Nut Size	Grade	Torque in. lbs
M12 x 40mm	M12	M12	M12	ISO 4.8	347 - 469 in. lbs

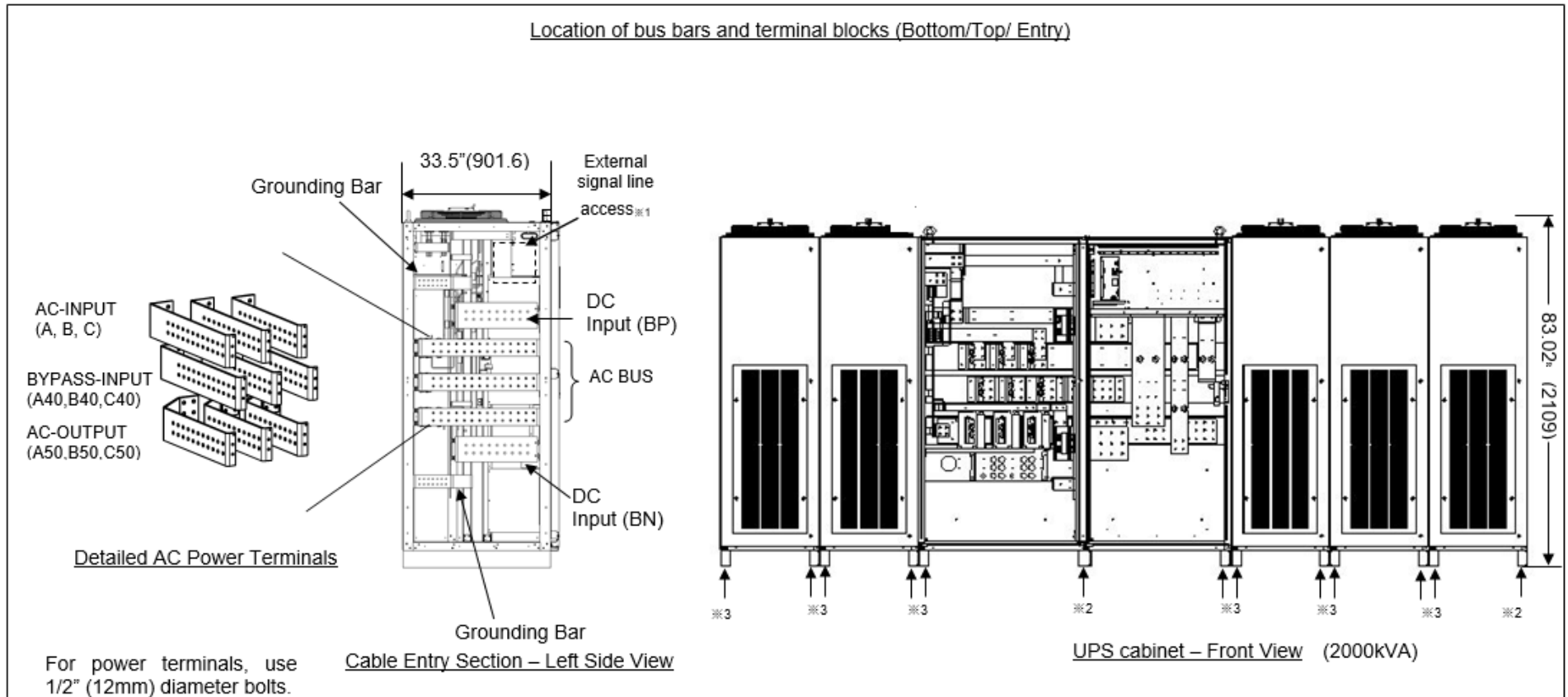


**Table 3.5** Crimp Type Compression Lug

WIRE SIZE (CODE)	WIRE STRAND CLASS	RECOMMENDATION		CRIMP TOOL REQUIRED BURNDY TYPE Y35 OR Y46	
		VENDOR	CAT. NO.	COLOR KEY	DIE INDEX
400 MCM	B	BURNDY	YA32	BLUE	19 / 470
	I	ILSCO	CRA-400L	BLUE	19 / 470
		BURNDY	YA36-LB	---	1027
500 MCM	B	BURNDY	YA34	BROWN	20 / 299
	I	ILSCO	CRA-500L	BROWN	20 / 299
		BURNDY	YA38-LB	---	1029
600 MCM	B	BURNDY	YA36	GREEN	22 / 472
	I	ILSCO	CRA-600L	GREEN	22 / 472
		BURNDY	YA39-LB	---	1030
750 MCM	B	BURNDY	YA39	BLACK	24
		ILSCO	CRA-750L	BLACK	24

NOTE: When using crimp type lugs, the lugs shall be crimped to the specifications given in the manufacturer's instructions for both crimp tool and lug.

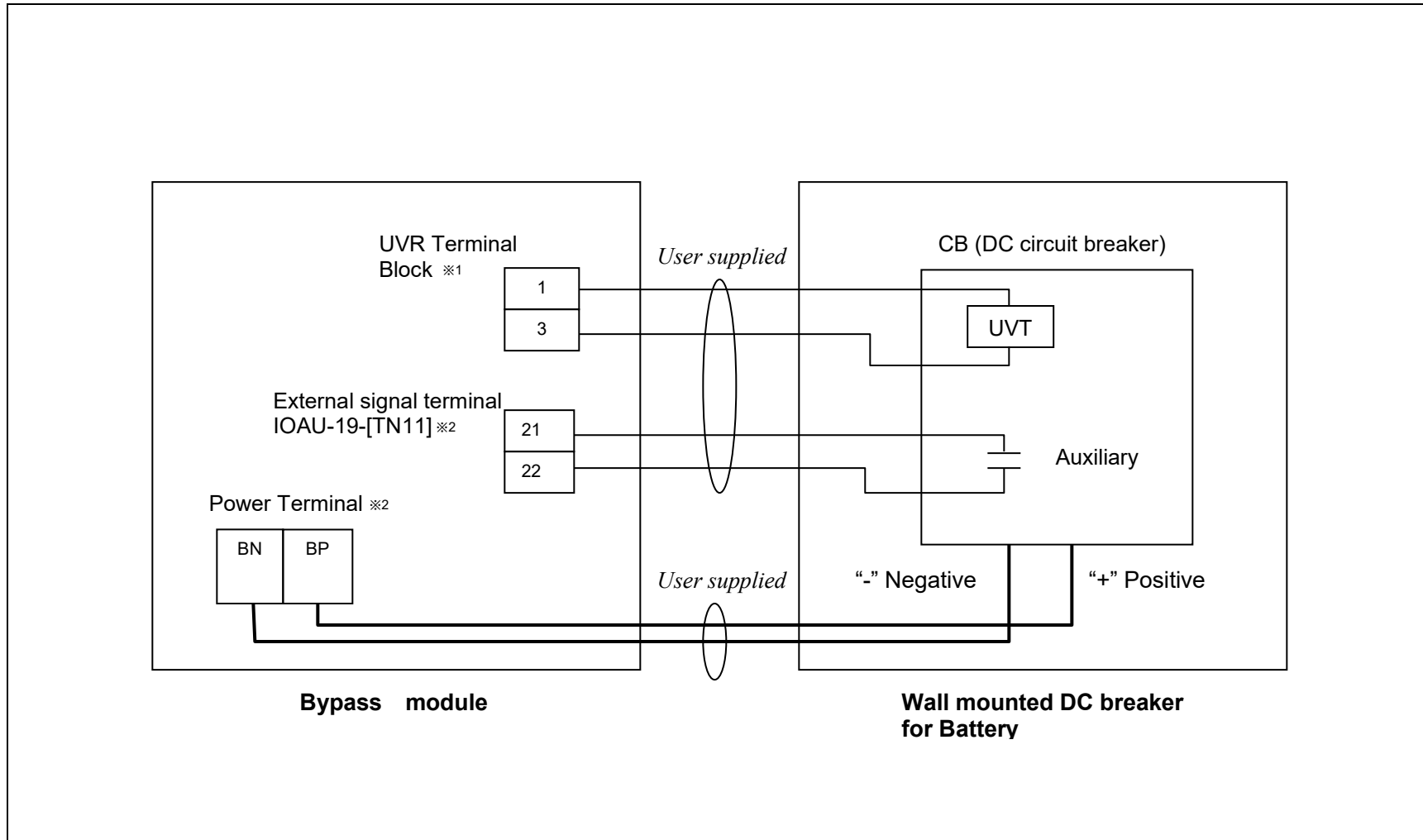
**Figure 3.6** UPS Terminal Designation


**Figure 3.7** Diagram of Input/Output Bus Bars and Terminal Blocks


※1. Signal lines should be separated to the main circuit cables with more than 100mm insulating distance. The wiring also should fix to the frame to ensure the insulating distance satisfied the condition.

※2. 3x 2-holes bases

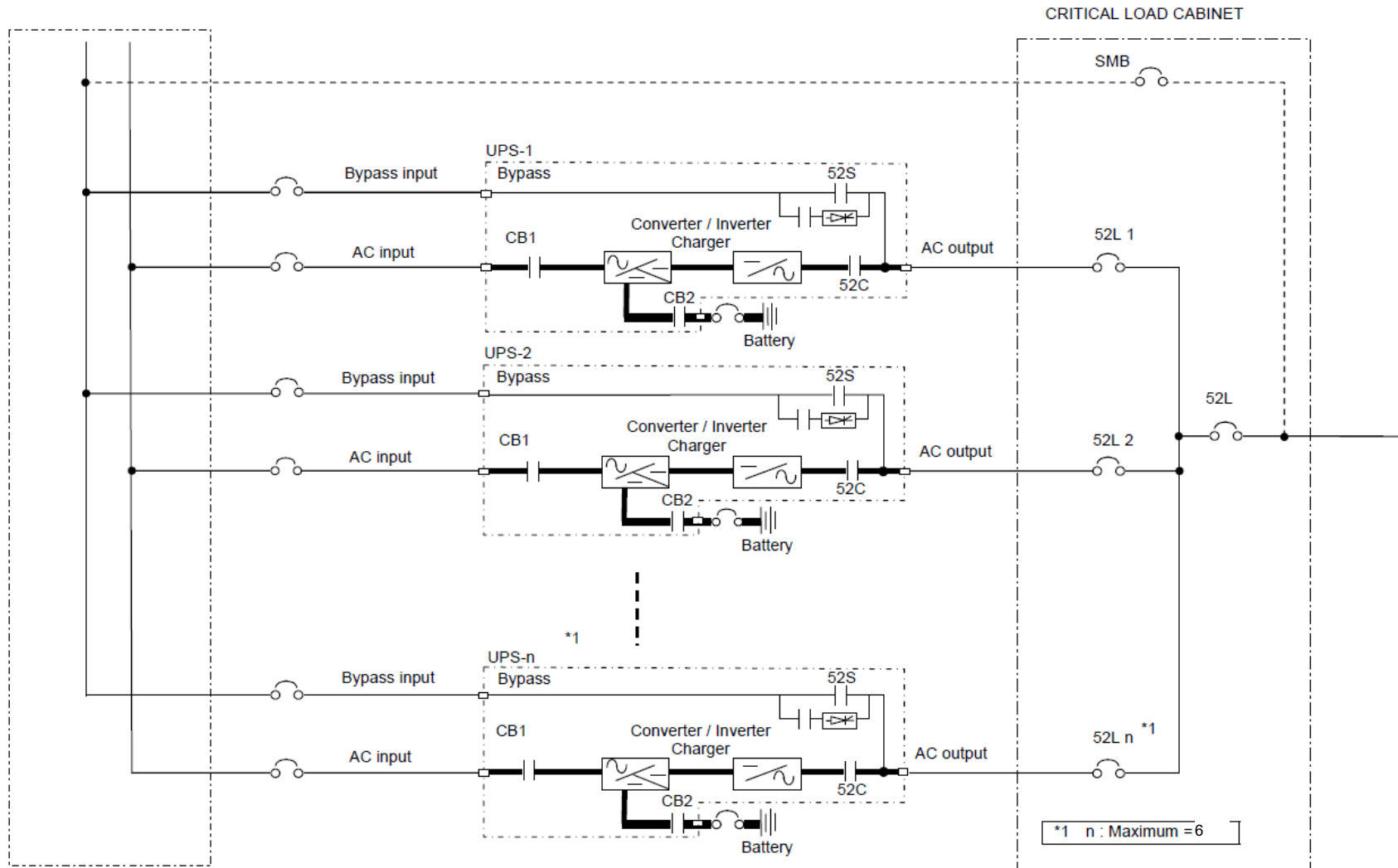
※3. 4x 4-holes bases

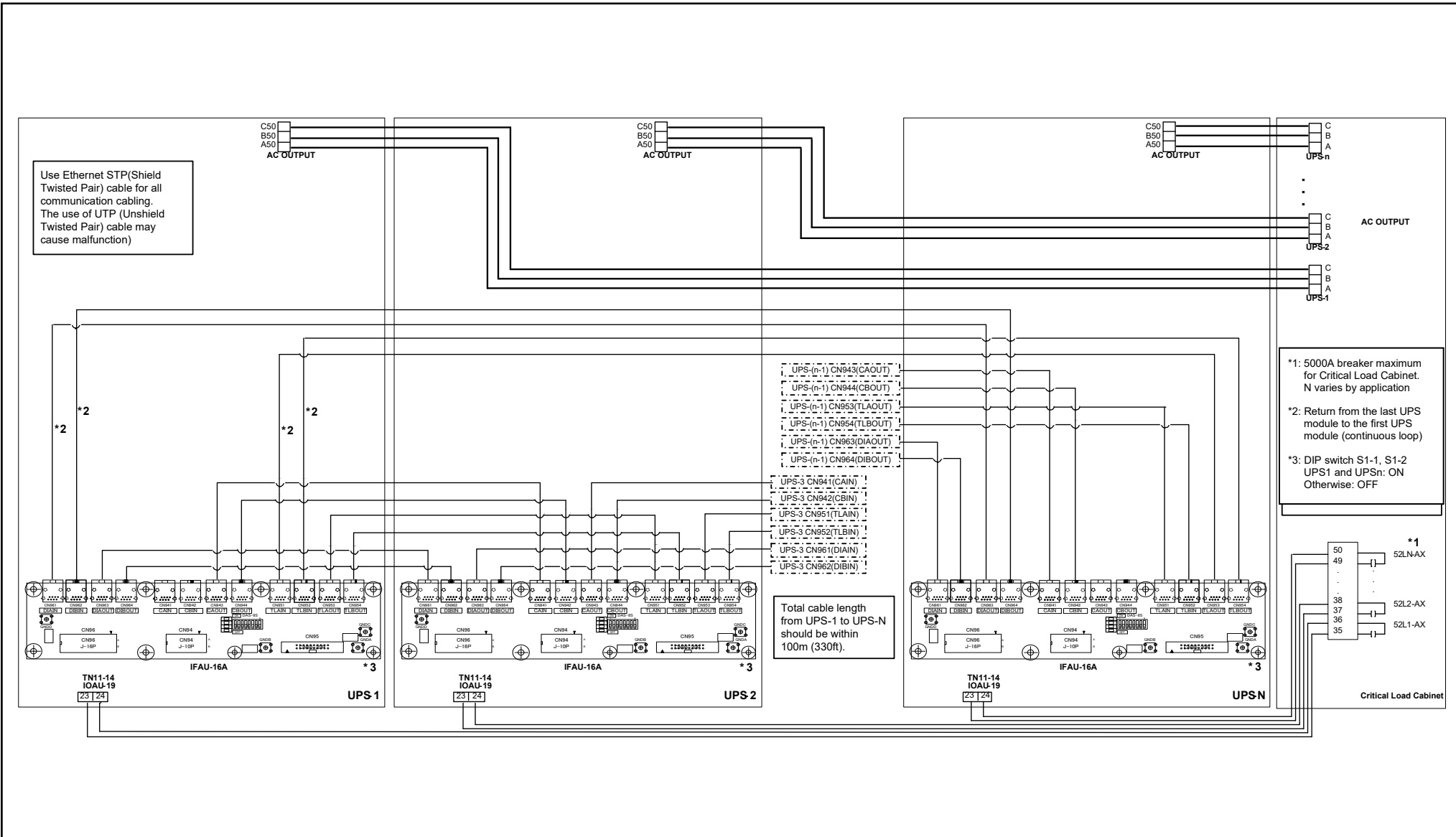
**Figure 3.8** Diagram of Power Wire & Control Wire Interconnections between UPS and Battery


※1. Only applicable for units without an internal CB2

※2. Applicable for all 9900D configurations



**Figure 3.9** Diagram of power wire connections (Parallel Operation system connection)


**Figure 3.10(a)** Diagram of Power Wire & Control Wire Connect (Parallel Operation System Connection 2x to 6x)


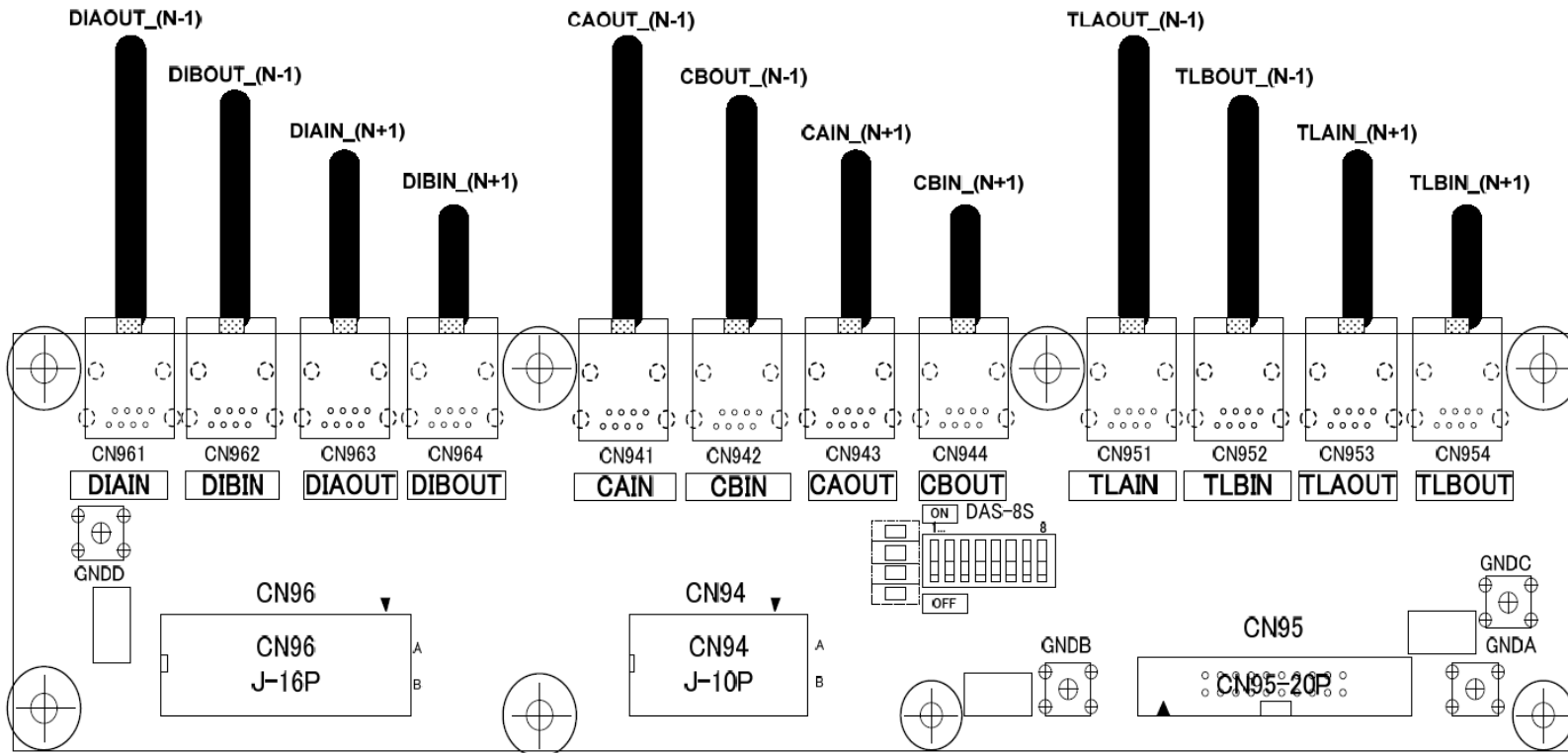
**Figure 3.10(b)** Outline Drawing of IFAU-16 and Parallel System Operation Connection

## UPS-N

\* UPS-N(Last) : N+1 -> 1  
 UPS-1 : N-1 -> N(Last)  
 (continuous loop)

\* DIP switch S1-1, S1-2; UPS-1 and UPS-N : ON  
 Otherwise : OFF

\*CAIN, CBIN, CAOUT, CBOUT: no loop



**3.4 CONNECTION OF BATTERY UVR SIGNAL**

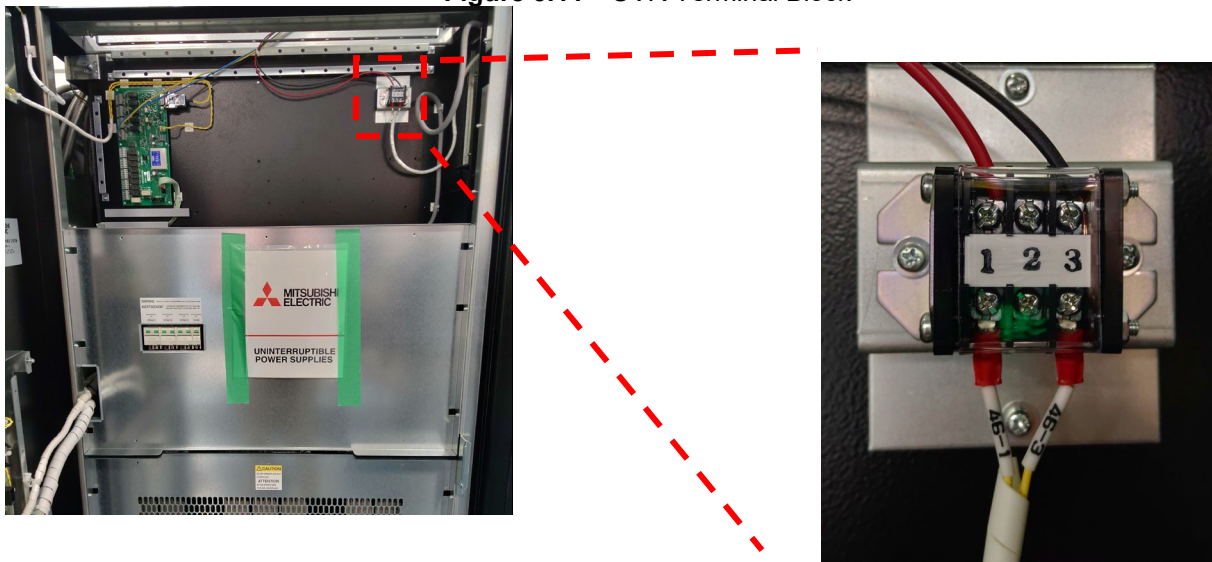


**NOTE**

**UVR section only applicable for units without an internal CB2. Units that do not include an internal CB2 contactor must use a 24VDC UVR with the battery cabinet circuit breaker.**

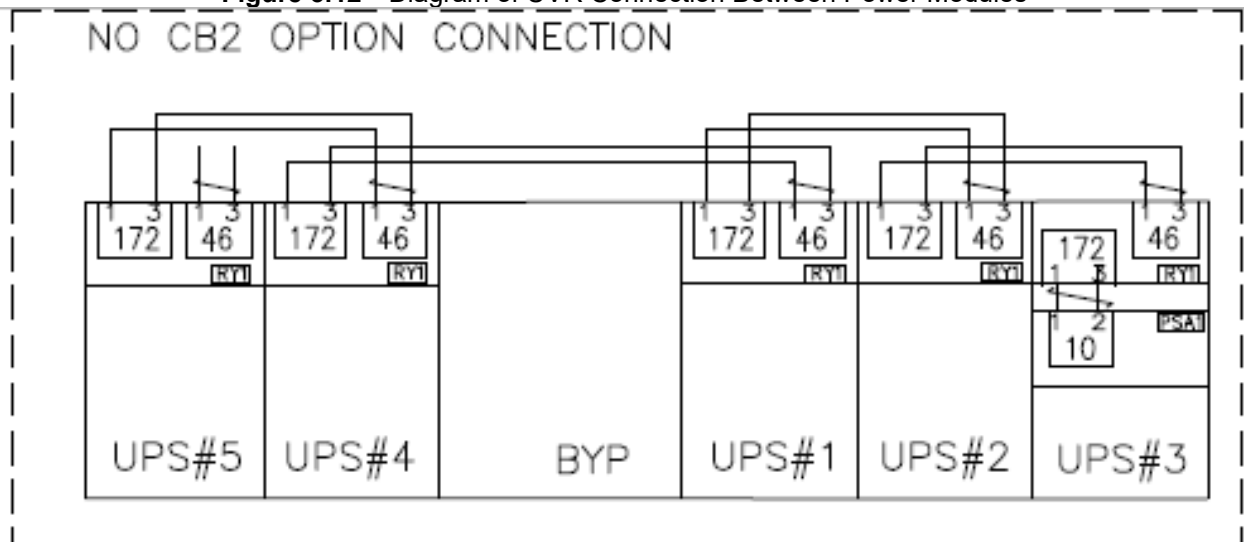
1. In the Bypass Cabinet, connect the 2 loose yellow wires to the UVR terminal block. Attach wires 46-1 to terminal #1 and 46-3 to terminal #3 as shown in Figure 3.11. See Figure 3.12 for full wiring diagram.

**Figure 3.11 UVR Terminal Block**



2. Connect the remaining UVR signal wires between power modules as shown in Figure 3.12.

**Figure 3.12 Diagram of UVR Connection Between Power Modules**



## 4.0 OPERATING PROCEDURES

For Parallel Operation system, refer to section “D) MMS Start-up Procedure”.  
(Parallel Operation system is herein after MMS [Multi Module System])

### A) Start Operation



Before the UPS startup, the internal Bypass line starts to supply the unconditioned bypass input power to the critical load if the External input (or Bypass) Circuit Breaker is closed. Be extremely careful with closing the External input (or Bypass) Circuit Breaker.

- a) Verify that the External Bypass Input Circuit Breaker for each unit is closed (user supplied). If a dual source is feeding the UPS, close the External AC Input Circuit Breaker (user supplied) manually also.
- b) Close Battery Disconnect Circuit Breaker (user supplied).
- c) The LCD panel boots up automatically, and the screen will show that the Load is powered by bypass line.
- d) On the LCD panel, press the “TRANSFER” button, and then press the “START INVERTER” button to proceed UPS start-up. (Refer to Figure 2.3).
- e) Follow the “START INVERTER” guidance accordingly until the completion of the inverter startup.



**NOTE**

When “REMOTE OPERATION MODE” is displayed on the LCD panel, the inverter start operation can only be performed remotely. If local inverter start operation is required (at the UPS), select “LOCAL ONLY” or “REMOTE & LOCAL” in the OPERATION MENU.

### B) Stop Operation

If a total UPS shutdown is required, verify that the critical load is OFF.

- a.) On the LCD panel, press the “TRANSFER” button, and then press the “STOP INVERTER” icon to proceed UPS shutdown. (Refer to Figure 2.3)
- b.) Follow the “STOP INVERTER” guidance accordingly. During the procedure, UPS will transfer the power feeding from the Inverter supply to the Bypass line supply.
- c.) Both Converter and Inverter will remain energized until complete disconnection from all power sources.

**NOTE**

When "REMOTE OPERATION MODE" is displayed on the LCD panel, the inverter start operation can only be performed remotely. If local inverter stop operation is required (at the UPS), select "LOCAL ONLY" or "REMOTE & LOCAL" in the OPERATION MENU.

- d.) Open the Battery Disconnect circuit breaker(user supplied) manually.

**WARNING**

*Verify the load is OFF if the next step is to be performed .*

**NOTE**

**Power to the critical load is supplied through the bypass line. Power to the critical load will be lost after execution of the next step. The load will drop.**

- e.) If a dual source is feeding the UPS, open the External AC Input Circuit Breaker (user supplied) manually.
- f.) If turning off all power to the critical load is desired, open the External Bypass Input Circuit Breaker (user supplied) manually.

**WARNING**

**In bypass mode, all UPS power terminals are still live. Lethal voltages are present. De-energize all external sources of AC and DC power. Before removing the covers, wait 5 minutes after de-energizing. Check no-voltage before handling UPS. Be careful for the devices even when the UPS has been de-energized, still internal devices may be hot.**

### **C) Bypass Operation Procedure**

#### **\*\* Transfer from Inverter to Bypass**

1. Check for "SYNC" on the LCD.
2. Press the "TRANSFER" icon on the LCD.
3. Press the "TRANSFER TO BYPASS (SMS)" icon on the LCD.

\*\* Transfer from Bypass to Inverter.

1. Press the "TRANSFER" icon on the LCD.
2. Press the "TRANSFER TO INVERTER (SMS)" icon on the LCD..



**NOTE**

When "REMOTE OPERATION MODE" is displayed on the LCD panel, the inverter start operation can only be performed remotely. If local inverter start or stop operation is required (at the UPS), select "LOCAL ONLY" or "REMOTE & LOCAL" in the OPERATION MENU.

#### **D) MMS Start-up Procedure**

##### ***External Circuit Check***

1. Verify that Critical Load Cabinet (CLC) Circuit Breaker SMB is closed.
2. Verify that CLC System Output Circuit Breaker 52L is open.
3. Verify that CLC UPS Circuit Breakers 52L1, 52L2...and 52Ln are closed.

##### ***Start-up from UPS-1 to UPS-n***

1. Start-up each UPS in accordance with " A) Start Operation\* ". Each UPS will start Inverter Operation in synchronization with the bypass input.

\*Meaning of the icons in Figure 2.3(a) in MMS

**START INVERTER:** UPS Module Startup

**STOP INVERTER:** UPS Module Stop

**TRANSFER TO INVERTER (MMS):** Parallel-in\*\*

**TRANSFER TO BYPASS (MMS):** Parallel-off

\*\*No effect in MMS Bypass Operation

##### ***Transfer from Maintenance Bypass to MMS Bypass Operation***

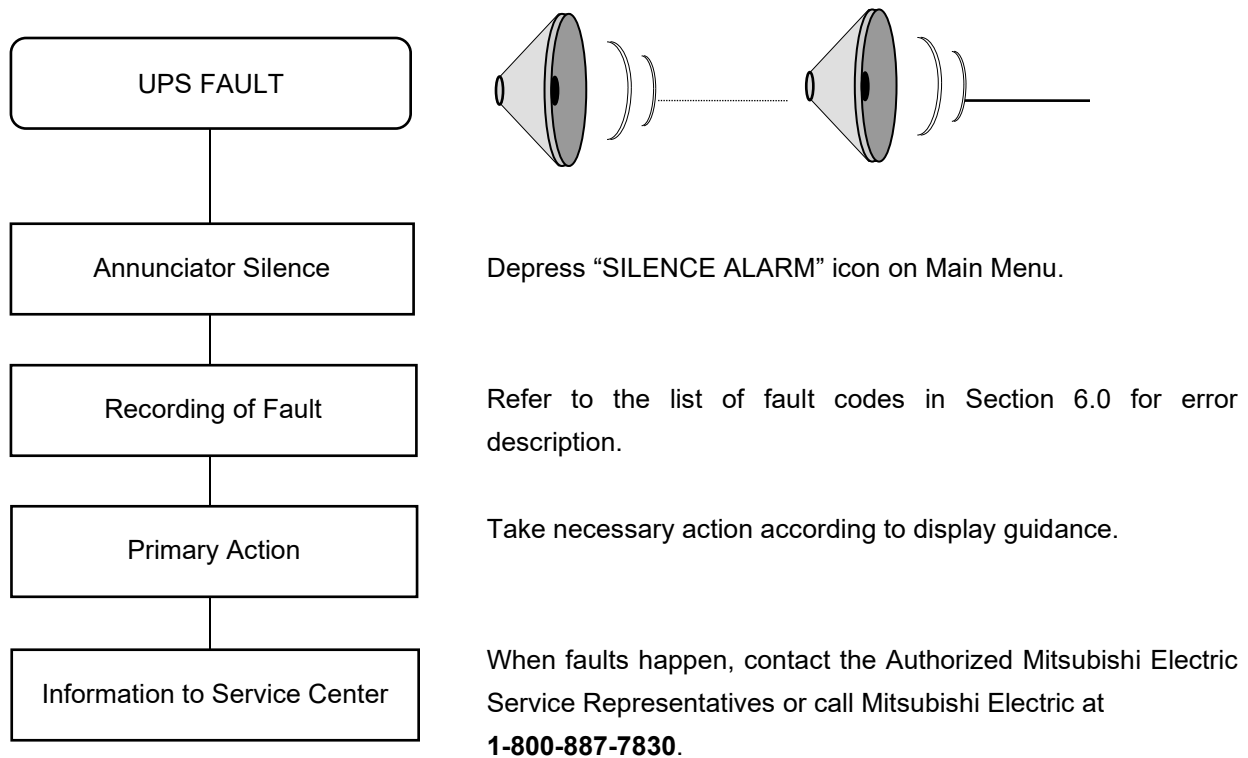
1. Close the CLC System Output Circuit Breaker 52L.
2. Open the CLC Circuit Breaker SMB.



**NOTE**

When "REMOTE OPERATION MODE" is displayed on the LCD panel, the inverter start operation can only be performed remotely. If local inverter start operation is required (at the UPS), select "LOCAL ONLY" or "REMOTE & LOCAL" in the OPERATION MENU.

## 5.0 RESPONSE TO UPS FAILURE



### NOTE

The error code indicated on the LCD display panel when an UPS alarms is very important. In order to reduce repair time, please include this information, along with the operation and load status for all correspondence to Mitsubishi Electric field service group.



## 6.0 PARTS REPLACEMENT

Contact Mitsubishi Electric Power Products, Inc. or its authorized service representatives on all issues regarding the replacement of parts.

### A) Battery

Battery lifetime may vary according to the frequency of use and the average ambient operating temperature. The end of battery life is defined as the state of charge resulting in an ampere-hour capacity less than, or equal to, 80% of nominal capacity.

Replace battery if its capacity is within this percentage.

### B) UPS Component Parts

UPS components have a defined life expectancy (Fan, Capacitors, Air-Filters, etc).

Contact Mitsubishi Electric Power Products, Inc. or its authorized service representatives for a complete parts replacement schedule. Recommended replacement time interval varies with operating environment.

Contact Mitsubishi Electric Power Products, Inc. or its authorized service representatives for application specific recommendations.



**Any parts replacements (including modification) without authorization from Mitsubishi Electric could result in personal injuries, death or destruction of the UPS.**

## **7.0 FAULT CODES**

This section covers fault codes, their description and required action.

In the event of a fault occurring:

- A) Verify and record the occurrence of the alarm. Note details of alarm message displayed on the LCD display panel.

**Contact Mitsubishi Electric Power Products, Inc. at 1-800-887-7830.**

- B) If a circuit breaker (MCCB) has tripped, depress the toggle to reset the breaker before closing it again.

**BYPASS MODULE FAULT CODES**
**Table 7.1** Bypass Module Fault Code List

Code indication (Note 2)	Status Message	Meaning	Guidance	Audible Alarm	External relay contact (Note 1)
UA805	OVERLOAD	The output load current has exceeded 100% of the rated current.	WARNING: DECREASE LOAD	Intermittent sound	Overload
UA806	INVERTER OVERLOAD	The output load current peak has exceeded 220% of the rated current.	WARNING: DECREASE LOAD	Intermittent sound	Overload
UA807	INVERTER OVERLOAD	The output load current has exceeded 105%~149% of the rated current.	WARNING: DECREASE LOAD	Intermittent sound	Overload
UA808	OVERLOAD	The output load current has exceeded 100% of the rated current during bypass supply.	WARNING: DECREASE LOAD	Intermittent sound	Overload
UA810	OVERLOAD	Short time over-current has exceeded 150% of the rated current.	WARNING: DECREASE LOAD	Intermittent sound	Overload
UA812	BYPS.VOLT.OUT RNG.	Bypass line voltage is out of the specific range. (Detection Level: <87%, >112%)	CHECK BYPASS INPUT	Intermittent sound	Bypass Input Abnormal
UA813	BYPS.PHASE ABNL.	Bypass line power conductors are not wired in a proper phase sequence.	CHECK BYPASS INPUT	Intermittent sound	Bypass Input Abnormal
UA814	BYPS.FREQ.OUT RNG.	Bypass line frequency is out of the specific range. (Detection Level: Frequency Bandwidth +0.2%)	CHECK BYPASS INPUT	Intermittent sound	Bypass Input Abnormal
UA815	TRANSFER PROHIBITION	Transfer to bypass is not available due to bypass abnormality.	-	Intermittent sound	-
UA816	BYP.VOLT.OUT RNG.2	Bypass line voltage is out of the specified range at ECO mode.	CALL SERVICE ENGINEER	Intermittent sound	-
UA817	EMERG.STOP ACTIV.	The emergency stop was activated by the EPO switch or an external contact.	-	Continuous sound	-
UA818	MODULE STOP	Input Failure and UPS stop (Indiv. BAT only)	-	Intermittent sound	-
UA821	REM. BUTTON CLOSE	The UPS could not transfer to the bypass because the inverter output was not synchronized to the bypass.	-	Intermittent sound	-
UA822	LOC. BUTTON ABNL.	The UPS could not transfer to the bypass because of backup generator operation.	CALL SERVICE ENGINEER	Intermittent sound	-
UA824	CB2 OPEN	The battery circuit breaker (CB2) is open.	TURN ON CB2	Intermittent sound	-
UA831	EMERG.BYPS.SW.ON	Emergency bypass switch has been turned on.	CALL SERVICE ENGINEER	Intermittent sound	-
UA833	52L OPEN	The load circuit breaker (52L) is turned off.	-	Intermittent sound	-
UA834	BATTERY DEPLETED	The battery voltage has reached the depleted level (400V).	CALL SERVICE ENGINEER	-	Battery Depleted
UA835	TRANS.INHIBITED	The UPS could not transfer to the bypass because the bypass source has an abnormality.	-	-	-

**Table 7.1** Bypass Module Fault Code List

Code indication (Note 2)	Status Message	Meaning	Guidance	Audible Alarm	External relay contact (Note 1)
UA837	BATTERY DEPLETED2	The calculated battery temperature has reached the limit level due to the long-time large discharging.	CALL SERVICE ENGINEER	-	End-of-Discharge
UA861	MODULE ALARM	Any Module Alarm	CALL SERVICE ENGINEER	Intermittent sound	-
UA862	MODULE MINOR FAULT	Any Module Minor Fault	CALL SERVICE ENGINEER	Intermittent sound	-
UA863	MOD.IN.VOLT.	Any Module Input Voltage Abnormality.	CHECK INPUT POWER SOURCE	Intermittent sound	AC Input Abnormal
UA864	MODULE OVERLOAD	Any Module Overload	WARNING : DECREASE LOAD	Intermittent sound	Overload
UA865	MOD.BAT.END	Any Module End of Battery	CALL SERVICE ENGINEER	-	Alarm
UA866	BATT.END WA	Approaching End of Battery	-	Intermittent sound	Alarm
UA867	OVERTEMPERTURE	Battery Overtemperature	CALL SERVICE ENGINEER	Intermittent sound	Alarm
UA868	CPMC OPEN	CPMC open	CALL SERVICE ENGINEER	Intermittent sound	Alarm
UA890	EXTERNAL ALARM	External alarm relay turned on.	-	Intermittent sound	Alarm
UA891	CHG. PROHIBITED	The relay turned on.	-	Intermittent sound	Alarm
UA892	DISCHG. PROHIBITED	The relay turned on.	-	Intermittent sound	Alarm
UA893	Battery Abnormal	Battery Abnormal input port is activated.	-	Intermittent sound	Alarm
UF006	CONVERTER ABNORMAL	Load On Battery /INV mixed for two (2) min.	CALL SERVICE ENGINEER	Intermittent sound	Major
UF055	CONVERTER ABNORMAL	Load On Battery /INV mixed for 20 sec.	CALL SERVICE ENGINEER	Intermittent sound	Minor
UF151	BAT.VOLTAGE ABNL.	24 hours after input power restoration, batteries do not reach float voltage level.	CALL SERVICE ENGINEER	Intermittent sound	Minor
UF152	BAT.VOLTAGE ABNL.	Unable to equalize the voltage of various batteries after 24 hours.	CALL SERVICE ENGINEER	Intermittent sound	Minor
UF156	CHG.STOPPED	UF157 failure persisted for over two (2) hours.	CHECK BATTERY	Intermittent sound	Battery abnormal
UF157	BATTERY OVERTEMP.	Detection of overtemperature at the batteries.	CHECK BATTERY	Intermittent sound	Battery abnormal
UF158	BATTERY LIQUID LOW	Low level of battery electrolyte solution.	CHECK BATTERY	Intermittent sound	Battery abnormal
UF161	CHG.STOPPED	UF151 failure is running for over 24 hours.	CALL SERVICE ENGINEER	Intermittent sound	Minor
UF162	BATTERY ABNORMAL	Failure detection based on battery self-check.	CALL SERVICE ENGINEER	Intermittent sound	Minor

**Table 7.1** Bypass Module Fault Code List

Code indication (Note 2)	Status Message	Meaning	Guidance	Audible Alarm	External relay contact (Note 1)
UF163	BAT.VOLTAGE ABNL.	Battery voltage is abnormal	CALL SERVICE ENGINEER	Intermittent sound	Minor
UF202	INVERTER UV.	Output voltage dropped.	CALL SERVICE ENGINEER	Continuous sound	Major
UF253	CTRL.CIRCUIT ERR.	Discrepancy between output voltage and bypass voltage during bypass operation.	CALL SERVICE ENGINEER	Intermittent sound	Minor
UF254	CTRL.CIRCUIT ERR.	Discrepancy between Bypass voltage and inverter voltage at transfer.	CALL SERVICE ENGINEER	Intermittent sound	Minor
UF256	O/P VOLTAGE ABNL.	Output voltage is out of the specified range.	CALL SERVICE ENGINEER	Intermittent sound	Minor
UF258	LOAD ABNORMAL	Load transfer due to overload for over 4 times within 5 minutes.	CALL SERVICE ENGINEER	Intermittent sound	Minor
UF301	CTRL.CIRCUIT ERR.	AD reference has an abnormal value.	CALL SERVICE ENGINEER	Continuous sound	Major
UF302	CTRL.CIRCUIT ERR.	Detection of an external interruption during the software execution.	CALL SERVICE ENGINEER	Continuous sound	Major
UF303	CTRL.CIRCUIT ERR.	Timer does not reset in the specified period (WDT settings)	CALL SERVICE ENGINEER	Continuous sound	Major
UF305	CTRL.CIRCUIT ERR.	Detection of an abnormal clock speed in the CPU or FPGA.	CALL SERVICE ENGINEER	Continuous sound	Major
UF306	CTRL.CIRCUIT ERR.	Control power supply voltage is below the specified level.	CALL SERVICE ENGINEER	Continuous sound	Major
UF320	CTRL.CIRCUIT ERR.	Cable disconnection in the parallel interface board during load supply.	CALL SERVICE ENGINEER	Continuous sound	Major
UF321	CTRL.CIRCUIT ERR.	Bypass not recognized by CAN	CALL SERVICE ENGINEER	Continuous sound	Major
UF322	CTRL.CIRCUIT ERR.	Cable disconnection in the parallel interface board.	CALL SERVICE ENGINEER	Continuous sound	Major
UF323	CTRL.CIRCUIT ERR.	Cable disconnection in the parallel interface board.	CALL SERVICE ENGINEER	Continuous sound	Major
UF324	CTRL.CIRCUIT ERR.	CAN signal H/L stuck	CALL SERVICE ENGINEER	Continuous sound	Major
UF325	CTRL.CIRCUIT ERR.	Cable disconnection in the parallel interface board.	CALL SERVICE ENGINEER	Continuous sound	Major
UF326	CTRL.CIRCUIT ERR.	Communication Error (SMS)	CALL SERVICE ENGINEER	Intermittent sound	Minor
UF327	CTRL.CIRCUIT ERR.	Communication Error (MMS)	CALL SERVICE ENGINEER	Intermittent sound	Minor
UF340	MODULE MINOR FAULT	Module Major Fault	CALL SERVICE ENGINEER	Continuous sound	Major

**Table 7.1** Bypass Module Fault Code List

Code indication (Note 2)	Status Message	Meaning	Guidance	Audible Alarm	External relay contact (Note 1)
UF341	#1 MAJOR FAULT	#1 Module Major Fault	CALL SERVICE ENGINEER	Intermittent sound	Minor
UF342	#2 MAJOR FAULT	#2 Module Major Fault	CALL SERVICE ENGINEER	Intermittent sound	Minor
UF343	#3 MAJOR FAULT	#3 Module Major Fault	CALL SERVICE ENGINEER	Intermittent sound	Minor
UF344	#4 MAJOR FAULT	#4 Module Major Fault	CALL SERVICE ENGINEER	Intermittent sound	Minor
UF345	#5 MAJOR FAULT	#5 Module Major Fault	CALL SERVICE ENGINEER	Intermittent sound	Minor
UF346	#6 MAJOR FAULT	#6 Module Major Fault	CALL SERVICE ENGINEER	Intermittent sound	Minor
UF349	MODULE MAJOR FAULT	All Module Major Fault	CALL SERVICE ENGINEER	Continuous sound	Major
UF353	EX. I/F PCB ABNL.	Communication error with I/F PCB	CALL SERVICE ENGINEER	Intermittent sound	Minor
UF363	CTRL.CIRCUIT ERR.	Synchronization status signal is being received for a considerable time.	CALL SERVICE ENGINEER	Intermittent sound	Minor
UF371	CTRL.CIRCUIT ERR.	Minor communication error during parallel operation.	CALL SERVICE ENGINEER	Intermittent sound	Minor
UF372	CTRL.CIRCUIT ERR.	Unable to synchronize the inverter output and the bypass voltage.	CALL SERVICE ENGINEER	Intermittent sound	Minor
UF373	STS CONT.CIR.ERR.	STS current sensor abnormal (ECO)	CALL SERVICE ENGINEER	Intermittent sound	Minor
UF374	CTRL.CIRCUIT ERR.	Cable disconnection in the parallel interface board.	CALL SERVICE ENGINEER	Intermittent sound	Minor
UF375	CTRL.CIRCUIT ERR.	Unable to achieve synchronization for parallel operation.	CALL SERVICE ENGINEER	Intermittent sound	Minor
UF376	CTRL.CIRCUIT ERR.	No control response from another UPS although its detection is possible.	CALL SERVICE ENGINEER	Intermittent sound	Minor
UF377	CTRL.CIRCUIT ERR.	Overload detection signal is being received continuously for a considerable time.	CALL SERVICE ENGINEER	Intermittent sound	Minor
UF378	CTRL.CIRCUIT ERR.	No answer for sending synchronizing signal.	CALL SERVICE ENGINEER	Intermittent sound	Minor
UF381	CTRL.CIRCUIT ERR.	No module supply answer during UPS operation.	CALL SERVICE ENGINEER	Intermittent sound	Minor
UF382	CTRL.CIRCUIT ERR.	Module supply answer during UPS halt.	CALL SERVICE ENGINEER	Intermittent sound	Minor
UF383	CTRL.CIRCUIT ERR.	Module overcurrent answer continued for 10 seconds or more.	CALL SERVICE ENGINEER	Intermittent sound	Minor

**Table 7.1** Bypass Module Fault Code List

Code indication (Note 2)	Status Message	Meaning	Guidance	Audible Alarm	External relay contact (Note 1)
UF384	CTRL.CIRCUIT ERR.	Minor communication error by fall-out of only A-side of dual connector.	CALL SERVICE ENGINEER	Intermittent sound	Minor
UF385	CTRL.CIRCUIT ERR.	Minor communication error by fall-out of only B-side of dual connector.	CALL SERVICE ENGINEER	Intermittent sound	Minor
UF386	LCD FAULT	Communication error with LCD	CALL SERVICE ENGINEER	Intermittent sound	Minor
UF401	52S ABNORMAL	Error to close the contactor 52S.	CALL SERVICE ENGINEER	Continuous sound	Major
UF402	52S ABNORMAL	Error to open the contactor 52S.	CALL SERVICE ENGINEER	Continuous sound	Major
UF420	52L OPERATION ERR.	Load circuit breaker 52L opened during inverter operation.	CALL SERVICE ENGINEER	Continuous sound	Major
UF451	52S ABNORMAL	Contactor 52S failed during load transfer from inverter to bypass.	CALL SERVICE ENGINEER	Intermittent sound	Minor
UF452	CB3 ABNORMAL	Contactor CB3 is not working properly.	CALL SERVICE ENGINEER	Intermittent sound	Minor
UF453	STS TEMP. ABNORMAL	Thyristor temperature abnormal	CALL SERVICE ENGINEER	Intermittent sound	Minor

**UPS MODULE FAULT CODES**
**Table 7.2** UPS Module Fault Code List

Code indication (Note 2)	Status message	Meaning	External relay contact (Note 1)
MA801	I/P VOLT.OUT RNG.	Input line voltage is out of the specified range. (Detection Level: <78%, >116% )	Alarm
MA802	I/P FREQ.OUT RNG.	Input line frequency is out of the specified range. (Detection Level: +/-11% )	Alarm
MA803	I/P PHASE ABNL.	Input line power conductors are not wired in a proper phase sequence.	Alarm
MA806	INVERTER OVERLOAD	The inverter output current has exceeded 105% of the rated current.	Alarm
MA807	INVERTER OVERLOAD	The inverter output current has exceeded 125% of the rated current.	Alarm
MA810	INVERTER OVERLOAD	Short-time over-current has been detected during the inverter operation.	Alarm
MA817	EMERG.STOP ACTIV.	The emergency stop was activated by the EPO switch or an external contact.	Alarm
MA824	CB2 OPEN	The battery circuit breaker (CB2) is open.	Alarm
MA834	BATTERY DEPLETED	The battery voltage has reached the depleted level (400V).	Alarm
MA836	INVERTER OVERLOAD	The UPS could not transfer to the bypass because the bypass source has an abnormality.	Alarm
MA837	BATTERY DEPLETED2	The calculated battery temperature has reached the limit level due to the long-time large discharging.	Alarm
MA860	CB1 ABNORMAL	Unmatching in command and AX of CB1	Alarm
MA861	52C ABNORMAL	Unmatching in command and AX of 52C	Alarm
MA870	BALANCER OVERLOAD	The UPS detected a neutral point voltage unbalance. (Detection Level: dV>75Vdc )	Alarm
MA891	CHG. PROHIBITED	CHG. PROHIBITED is activated via input port.	Alarm
MA892	DISCHG. PROHIBITED	DISCHG. PROHIBITED is activated via input port.	Alarm
MA893	BATTERY ABNORMAL	BATTERY ABNORMAL is activated via input port.	Alarm
MF001	I/P CIRCUIT ABL.	Detection of a large variation of the reference error signal.	Major
MF002	CONV OVERCURRENT	Detection of converter overcurrent. (Detection Level: 280%peak )	Major
MF003	CONVERTER ABNL.	Pre-charging circuit is not working properly.	Major
MF102	DC OVERVOLTAGE	DC voltage surpasses the overvoltage level. (Detection Level: >880Vdc )	Major



**Table 7.2** UPS Module Fault Code List

Code indication (Note 2)	Status message	Meaning	External relay contact (Note 1)
MF103	DC UNDERVOLTAGE	DC voltage dropped below the undervoltage level. (Detection Level: <630Vdc )	Major
MF104	DISCHARGE FAULT	Capacitor voltage is higher than 100V at 5 minutes after module stop.	Minor
MF108	CHOP OVERCURRENT	Detection of DC overcurrent. (Detection Level: 290%peak )	Major
MF109	DC UNBALANCED	Major unbalance of the neutral point voltage. (Detection Level: dV>150Vdc )	Major
MF110	ZERO PHASE OC.	Major unbalance of the neutral point voltage. (Detection Level: >50% )	Major
MF111	CTRL.CIRCUIT ERR.	Battery current unbalance. (Detection Level: dl>25% )	Major
MF112	DC CIRCUIT ABNL.	Sudden change of the DC voltage level.	Major
MF119	DC GROUND FAULT	Detection of DC ground fault.	Major
MF128	CTRL.PWR. ABNL.	Power supply voltage to IGBT driver PCB is below the specified level.	Major
MF151	BAT.VOLTAGE ABNL.	24 hours after input power restoration, batteries do not reach float voltage level.	Minor
MF152	BAT.VOLTAGE ABNL.	Unable to equalize the voltage of various batteries after 24 hours.	Minor
MF154	CB2 ABNORMAL	During UVT, status signal from CB2 is ON.	Minor
MF156	CHG. STOPPED	UF157 failure persisted for over two (2) hours.	Minor
MF157	BATTERY OVERTEMP.	Detection of overtemperature at the batteries.	Minor
MF159	DC GROUND FAULT	Detection of DC ground fault.	Minor
MF160	CTRL.CIRCUIT ERR.	Abnormal behavior of DC current sensor.	Minor
MF161	CHG.STOPPED	UF151 failure is running for over 24 hours.	Minor
MF162	BATTERY ABNORMAL	Failure detection based on battery self-check.	Minor
MF163	BAT.VOLTAGE ABNL.	Battery voltage is abnormal.	Minor
MF179	DC GROUND FAULT	Detection of DC ground fault continued for 5 minutes.	Minor
MF201	INVERTER OV.	Detection of output overvoltage.	Major

**Table 7.2** UPS Module Fault Code List

Code indication (Note 2)	Status message	Meaning	External relay contact (Note 1)
MF202	INVERTER UV.	Output voltage dropped.	Major
MF203	INVERTER OC.	Detection of inverter overcurrent.	Major
MF204	O/P CIRCUIT ABNL.	Detection of a large variation of the reference error signal (current reference and actual current).	Major
MF207	ZERO PHASE OC.	Inverter zero-sequence overcurrent.	Major
MF208	CTRL.CIRCUIT ERR.	Cross current is abnormal.	Major
MF210	52C ABNORMAL	Error to open the contactor 52C.	Major
MF213	OVERTEMPERATURE	Heatsinks temperature exceeds thermal settings.	Major
MF214	COOLING FAN ABNL.	Thermal relay activated protection.	Major
MF217	INVERTER OV.	Detection of inverter output phase overvoltage.	Major
MF230	ZERO PHASE OC.	Detection of zero-sequence overcurrent.	Major
MF253	CTRL.CIRCUIT ERR.	Discrepancy between output voltage and inverter voltage, or between output voltage and bypass voltage.	Minor
MF254	COOLING FAN ABNL	Fan Failure (Minor)	Minor
MF256	O/P VOLTAGE ABNL.	Output voltage is out of the specified range.	Minor
MF301	CTRL.CIRCUIT ERR.	AD reference has an abnormal value.	Major
MF302	CTRL.CIRCUIT ERR.	Detection of an external interruption during the software execution.	Major
MF303	CTRL.CIRCUIT ERR.	Timer does not reset in the specified period (WDT settings)	Major
MF305	CTRL.CIRCUIT ERR.	Detection of an abnormal clock speed in the DSP or FPGA.	Major
MF306	CTRL.CIRCUIT ERR.	Control power supply voltage is below the specified level.	Major
MF309	INV.VOLTAGE ABNL.	Inverter voltage is out of the specified range.	Major
MF320	CTRL.CIRCUIT ERR.	Cable disconnection in the parallel interface board during load supply.	Major
MF331	CTRL.CIRCUIT ERR.	Cable disconnection in the main driver PCB (Phase U)	Major

**Table 7.2** UPS Module Fault Code List

Code indication (Note 2)	Status message	Meaning	External relay contact (Note 1)
MF332	CTRL.CIRCUIT ERR.	Cable disconnection in the main driver PCB (Phase V)	Major
MF333	CTRL.CIRCUIT ERR.	Cable disconnection in the main driver PCB (Phase W)	Major
MF334	CTRL.CIRCUIT ERR.	Cable disconnection in the main driver PCB (Chopper)	Major
MF376	CTRL.CIRCUIT ERR.	No control response from another UPS although its detection is possible.	Minor
MF552	DUMMY FAULT	Dummy fault for test	Major

(Note 1) 1) "Major" is defined as a major failure. Load transferred from the inverter circuit to the static bypass line;

2) "Minor" is defined as a minor failure. UPS continues to operate normally, but the cause of alarm must be identified;

(Note 2) Code indication means:

#A+++ ----- Alarm  
 #F+++ ----- Failure  
 #%0++ ----- Rectifier circuit failure  
 #%1++ ----- DC circuit failure  
 #%2++ ----- Inverter circuit failure  
 #%3++ ----- Control circuit failure  
 #%4++ ----- Bypass system failure  
 #%8++ ----- Alarm

"#" Bypass Module "U", UPS Module "M"

"+" denotes any numeral from 0 to 9

"%" denotes either "A" or "F"

## **8.0 WARRANTY & OUT OF WARRANTY SERVICE**

### **Important Warranty Information**

- For customers purchasing a new Uninterruptible Power Supply (UPS) directly from Mitsubishi Electric Power Products, Inc., the Limited Warranty of your Uninterruptible Power Supply (UPS) was provided to you at the time of sale.
- For customers purchasing a new Uninterruptible Power Supply (UPS) from a Reseller, the Limited Warranty of your Uninterruptible Power Supply (UPS) was provided to the Reseller at the time of sale. Please contact Mitsubishi Electric Power Products Inc. immediately if formal documentation of the warranty transfer was not provided to you.
- To ensure prompt support please update your Product Registration information [www.mitsubishicritical.com/registration](http://www.mitsubishicritical.com/registration) at completion of startup and whenever the registered contacts responsible for your UPS change.
- Additional copies of our Limited Warranty and your Product Registration are available upon request at [www.mitsubishicritical.com/registration](http://www.mitsubishicritical.com/registration) or calling 1-800-887-7830 or 1-724-772-2555.

## **9.0 MAINTENANCE CONTRACTS**

For information on maintenance contracts and other service offerings, please visit [www.mitsubishicritical.com/services](http://www.mitsubishicritical.com/services).

