



MITSUBISHI ELECTRIC POWER PRODUCTS, INC.

UNINTERRUPTIBLE POWER SUPPLY SYSTEM

MODEL

1100A SERIES

OWNER'S / TECHNICAL MANUAL

UNINTERRUPTED Peace of Mind®

Preface

TABLE OF CONTENTS

LIST OF TABLES.....	II
LIST OF FIGURES	III
HOW TO USE THIS MANUAL	IV
1 INTRODUCTION	1-1
1.1 SAFETY PRECAUTIONS.....	1-2
1.2 GENERAL	1-9
1.3 DEFINITIONS.....	1-10
1.4 OPERATION OVERVIEW	1-11
1.5 SPECIFICATIONS	1-18
2 OPERATOR CONTROLS AND INDICATORS.....	2-1
2.1 EMERGENCY POWER OFF BUTTON (1).....	2-1
2.2 LIQUID CRYSTAL DISPLAY (2)	2-1
2.3 EXTERNAL SIGNAL TERMINAL BLOCK	2-7
2.4 EXTERNAL COMMUNICATIONS.....	2-12
3 INSTALLATION AND OPERATION.....	3-1
3.1 UPS COMPONENTS	3-1
3.2 TRANSPORTATION AND INSTALLATION	3-2
3.3 HANDLING	3-2
3.4 INSTALLATION PROCEDURE	3-4
3.5 PROCEDURE FOR CABLE CONNECTIONS	3-9
3.6 OPERATING PROCEDURES	3-13
3.7 MAINTENANCE BYPASS SETUP PROCEDURES	3-15
4 RESPONSE TO UPS FAILURE	4-1
5 PARTS REPLACEMENT	5-1
6 FAULT CODES.....	6-1
6.1 BYPASS MODULE FAULT CODES.....	6-2
6.2 POWER CONVERTER MODULE FAULT CODES.....	6-5
7 WARRANTY & OUT OF WARRANTY SERVICE.....	7-1
8 MAINTENANCE CONTRACTS	8-2
8.1 TYPICAL OFFERINGS.....	ERROR! BOOKMARK NOT DEFINED.
8.2 PACKAGES.....	ERROR! BOOKMARK NOT DEFINED.

LIST OF TABLES

Table 1	UPS Installation and Operational Environment	1-6
Table 2	Rating Of AC Input Circuit Breaker	1-8
Table 3	Power Specifications	1-18
Table 4	UPS Module Cabinet Information (Battery Built-in Cabinet model)	1-18
Table 5	UPS Module Cabinet Information (Standard Cabinet model)	1-18
Table 6	Detail of Specifications* ▲	1-19
Table 7	Rating of Contactors and Fuses ▲	1-20
Table 8	List of UPS component weights.....	3-1
Table 9	How to Transport and Install the System	3-2
Table 10	List of UPS Weights (Battery Built-In Cabinet Model)	3-4
Table 11	List of UPS Weights (Standard Cabinet Model)	3-4
Table 12	Type and Number of Battery	3-6
Table 13	Maximum Permitted Fault Current	3-7
Table 14	Recommended Cable Size and Torque Requirements	3-9
Table 15	Crimp Type Compression Lug.....	3-10
Table 16	Recommended Hardware.....	3-10
Table 17	Bypass Module Fault Code List.....	6-2
Table 18	Converter Module Fault Code List.....	6-5
Table 19	Typical Offerings.....	Error! Bookmark not defined.

LIST OF FIGURES

Figure 1	Single Line Diagram - Normal Operation: Load Powered by UPS Inverter	1-11
Figure 2	Single Line Diagram - Bypass Operation: Load Fed Through Static Bypass Line	1-12
Figure 3	Single Line Diagram - Emergency Operation.....	1-13
Figure 4	UPS Parts Location (10, 20kVA only) --- Battery Built-In Cabinet Model	1-14
Figure 5	UPS Parts Location (10, 20, 30, 40, 50kVA) --- Standard Cabinet Model.....	1-15
Figure 6	UPS Parts Location (Bypass Module)	1-16
Figure 7	External I/F Module.....	1-16
Figure 8	Operation/Display Panel (Front panel)	2-1
Figure 9	Main Screen.....	2-2
Figure 10	Startup Guidance.....	2-2
Figure 11	Shutdown Guidance	2-2
Figure 12	Screen Select Menu	2-2
Figure 13	Input Values.....	2-3
Figure 14	Output Values.....	2-3
▲ Figure 15	Measurement During.....	2-3
Figure 16	Each Power Converter Module	2-3
Figure 17	Status Log	2-3
Figure 18	Battery Log	2-3
Figure 19	Power Converter Failure Log	2-3
Figure 20	Power Converter Failure Log	2-3
Figure 21	Remote/Local Operation Select	2-4
Figure 22	Date & Time adjustment.....	2-4
▲ Figure 23	Main Screen.....	2-4
Figure 24	Measurement Screen	2-4
Figure 25	Main Screen (Fault Indication)	2-5
Figure 26	Message Screen.....	2-5
Figure 27	MENU Tree.....	2-6
▲ Figure 28	External Signal Terminal Block (NEC Class2)	2-8
▲ Figure 29	External Signal Terminal Block (NEC Class2)	2-9
Figure 30	Control Wiring for External Contacts.....	2-10
Figure 31	Remote "Start" Contact Connections	2-11
Figure 32	UPS Components.....	3-1
Figure 33	Handling.....	3-3
Figure 34	Clearance For Ventilation And Maintenance	3-5
Figure 35	Rear Clearance for Ventilation and Maintenance for Battery Built-In Cabinet Mode	3-5
Figure 36	Install Power Converter Module and Bypass Module	3-8
Figure 37	Hardware Configuration	3-10
Figure 38	UPS Terminal Designation Battery Built-In Cabinet Model (10kVA, 20kVA UPS)	3-11
Figure 39	UPS Terminal Designation Standard Cabinet Model (10kVA, 20kVA, 30kVA, 40kVA, 50kVA UPS)	3-11
Figure 40	Input/Output Power Terminals	3-12

HOW TO USE THIS MANUAL

This manual is designed for ease of use, giving the user an easy and quick reference to information. This manual uses notice icons to draw the user to important information regarding the safe operation and installation of the UPS. The notice icons used in this manual are explained below, and should be taken into account and adhered to whenever they appear in the text of this manual.



WARNING

WARNING: A warning symbol shows a potentially hazardous situation or condition that could result in personal injury or death if not avoided.



CAUTION

CAUTION: A caution symbol shows a potentially hazardous situation or condition that could result in personal injury or equipment damage if not avoided.



NOTE

NOTE: A note symbol shows information the user or the service personnel should observe during UPS operation or service work.



INHIBIT

INHIBIT: An inhibit symbol shows an act the user or service personnel should NEVER perform during UPS installation, operation or service work.

Safety Recommendations: If any problems are encountered while following this manual, Mitsubishi Electric field service group assistance and correspondence is recommended and can be reached at 1-800-887-7830.

1 INTRODUCTION

Your Mitsubishi Uninterruptible Power Supply System (UPS) is designed to provide many years of reliable power supply and protection from power failure, brown-outs, line noise and voltage transients. This manual contains descriptions for the installation and operation procedures of the UPS. To ensure optimal performance of the equipment, follow the manufacturer's instructions accordingly. Please read this manual carefully and retain it for future reference.



CAUTION

**IMPORTANT SAFETY INSTRUCTIONS
SAVE THESE INSTRUCTIONS**

This manual contains important instructions for the 1100A Series Uninterruptible Power Supply System that should be adhered to during installation, operation and maintenance of the UPS and its batteries.



WARNING

WARNING 1

**Lethal voltages exist within the equipment during operation.
Observe all warnings and cautions in this manual.
Failure to comply may result in serious injury or death.
Obtain qualified service for this equipment as per instructions.**



WARNING

WARNING 2

**In no event will MITSUBISHI be responsible or liable for either indirect or consequential damage or injury that may come from the use of this equipment.
Any modifications without authorization by MITSUBISHI could result in personal injuries, death or destruction of the UPS.**

This device complies with Part 15 of the FCC Rules. Operation is subject to the following two conditions:

- (1) This device may not cause harmful interference, and
- (2) This device must accept any interference received, including interference that may cause undesired operation.

1.1 SAFETY PRECAUTIONS

The safety precautions are categorized as **DANGER** and **CAUTION** in this manual.

DANGER : A dangerous situation may occur if improperly handled, leading to severe or fatal injuries.

CAUTION : A dangerous situation may occur if improperly handled, leading to minor or serious injuries.

Note that some items described as **CAUTION** may lead to severe results depending on the situation. Nonetheless, the important information outlined in this section must be observed at all times.

DANGER ▲

- Do not dispose the batteries in fire, as they may explode.
- Do not open or break the batteries. Released electrolytes are toxic and harmful to the eyes and skin.
- A battery can present a risk of electrical shock and high short circuit current. Observe the following minimum Safety Precautions when working on the batteries:
 - 1) Remove watches, rings or other metal objects.
 - 2) Use tools with insulated handles to prevent inadvertent shorts.
 - 3) Wear rubber gloves and boots.
 - 4) Do not lay tools or metal parts on top of the batteries.
 - 5) Disconnect the charging source prior to connecting or disconnecting battery terminals.
 - 6) Determine if the battery is inadvertently grounded. If so, remove the grounding source. Contact with any part of a grounded battery can result in electrical shock. The likelihood of such a shock will be reduced if grounds are removed during installation and maintenance.

▲ For other stored energy systems, refer to the supplement..

CAUTION

PRECAUTIONS FOR INSTALLATION

- **Do not block the intake/exhaust ports.**
 - If the intake/exhaust ports are blocked, the internal temperature of the UPS will rise, which could lead to fires from battery electrolyte leakage, fire ignition or part deterioration.
 - Exhaust from the rear of the equipment can be released at elevated temperatures. If any other equipment is expected to be installed in the area behind this one, put adequate distance between the two.
- **Follow the UPS instruction manual carefully when installing the unit.**
 - Improper installation could lead to injury, such as the UPS falling over, etc.

PRECAUTIONS FOR WIRING

- **The power supply for this unit must be three-phase rated in accordance with the equipment data plate. It must be suitably grounded.**
 - Failure to ground the unit could lead to electrical shocks.

PRECAUTIONS FOR USE

- **If a unit fault, abnormal odor or noise occurs, turn off the UPS input switch.**
 - Failure to do so could lead to fires.
- **Do not insert blunt objects or fingers, etc., in the fan.**
 - Failure to observe this could lead to injuries.
- **Do not insert blunt objects or fingers, etc., into the unit's input/output section.**
 - Failure to observe this could lead to electrical shocks.
- **Ventilate the UPS surroundings.**
 - Failure to do so could lead to container rupture or explosions from the gas generated from the battery system.
- **Prohibit smoking and the use of fire around the unit.**
 - Failure to do so could lead to injuries, damage or fires from explosions.
- **Do not place containers that have water or any liquids on the UPS.**
 - If the container tips over and the water or liquid spills, electrical shocks and fires in the UPS could occur.
- **Do not sit on, step on or lean on the UPS.**
 - Failure to observe this could lead to injuries if the UPS tips over.

CAUTION

PRECAUTIONS FOR MAINTENANCE AND INSPECTION

- **The inside of the UPS must be inspected or repaired by qualified personnel only.**
 - Failure to observe this could lead to electrical shocks, injuries, burns, smoke generation or fires.
- **Periodically replace the battery.**
 - Batteries that have exceeded the replacement life could lead to fires from electrolyte leakage or fire ignition.
- **Contact the dealer or service company for unit maintenance and repairs, and for the replacement of defective parts.**
 - Opening the cover could lead to electrical shocks or burns.
 - Do not touch high temperature parts, such as radiation fins. Those high temperature parts may cause burn injuries even after the power is turned off.

PRECAUTIONS FOR BATTERY ▲

- **If the battery ignites, do not use water to extinguish the fire. Instead, use a powder (ABC) fire extinguisher.**
 - Using water could cause the fire to grow.
 - **Toxic diluted sulfuric acid exists in the battery.**
 - If electrolytes leak from the unit, avoid contact with the skin or clothes.
 - If electrolytes make contact with the skin or clothes, wash it thoroughly off with clean water.
 - If electrolytes make contact with the eyes, rinse immediately and thoroughly with clean water, and then see a doctor. The presence of sulfuric acid in the eyes could lead to blindness and adherence to skin could lead to burns.
- ▲ *For other stored energy systems, refer to the supplement..*

PRECAUTIONS FOR OPERATION

- **Operating method.**
 - To obtain stable operation, it is advisable that the UPS is operated on a continuous basis. Even if you start or stop the equipment at daily intervals, keep the converter running and only start or stop the inverter.
- **Extended shutdown.**
 - If the UPS is stopped for several months, operate the converter for a day or two at monthly intervals.
 - Charge the batteries; if left uncharged for a long time, they can run down due to self-discharge.
- **Do not touch live parts, even after the equipment is shutdown.**
 - Because the converter is kept operational after stopping the inverter, voltage is still applied to the internals of the equipment. It takes about 5 minutes after stopping the converter for the voltage across the DC circuit to dissipate to a safe level, which is in the range of 20V. Avoid contacting the live parts of the equipment and the supply side of the breaker because they stay energized even after the equipment shutdown steps are performed.

CAUTION

OTHER PRECAUTIONS

- **Never use or store the unit in the following types of environmental conditions:**
 - a) A location having a low or high temperature or high humidity deviated from the ambient environmental conditions described in the brochure or instruction manual.
 - b) A location submerged in water or where the unit could become wet from dripping water.
 - c) At an altitude higher than 7400 feet (2220 meters).
 - d) In direct sunlight.
 - e) A location where organic solvents (gasoline, paint thinner, etc.) are stored.
 - f) A location that is dusty.
 - g) A location containing combustible gas, corrosive gas, salt or oil mist.
 - h) A location subject to vibration or impacts.
 - i) A location near devices that generate sparks or near heating elements.

APPLICATION

If the UPS System is to be applied to support equipment that could affect human safety, the following steps must be adhered to:

1. Consult with Mitsubishi Electric Power Products Inc. UPS Division at 1-800-887-7830.
2. Special consideration of the overall backup power system configuration is required so that the Mitsubishi UPS System is not the sole support required for operation, maintenance and management of power availability. Other available power sources (utility, emergency power generation or other systems) shall also support power availability.

Definition of equipment that could affect human safety:

- Life Support Systems: a system whose failure to perform can be expected to result in bodily injury or death.
- Essential Public Systems: a system whose failure to perform can be expected to result in bodily injury or death and/or property damage.



WARNING 3

The UPS must be installed and operated in a controlled environment. An improper storage and installation environment will deteriorate insulation, shorten component life, cause corrosion and equipment malfunctions, and can void your warranty. The standard installation and operational environment is as follows:

Table 1 UPS Installation and Operational Environment

Category	Acceptance Criteria		
Installation Location	Indoors, completely weather-protected location		
Altitude	0 – 2255 m (1524 – 2255 m <i>requires derating, contact MEPPi</i>)		
Ambient Temperature	32°F (0°C) to 104°F (40°C) Ideal operating temperature for batteries: 68°F (20°C) to 77°F (25°C)		
Relative Humidity	5% to 95% with no condensation		
Solid Contaminants (See Note 1)	<i>Parameter</i>	<i>Maximum value</i>	
	Sand	0	
	Dust/ Particulate matter (suspension)	<0.01 mg/m ³	
	Dust/ Particulate matter (sedimentation)	<0.4 mg/(m ² ·h)	
Chemical Contaminants (Gases and Vapors)	<i>Parameter</i>	<i>Mean value (See Note 2)</i>	<i>Maximum Value (See Note 3)</i>
	Sea salts	0	0
	Sulfur dioxide (SO ₂)	<0.01 PPM	<0.03 PPM
	Hydrogen sulfide (H ₂ S)	<0.003 PPM	<0.01 PPM
	Wet Chlorine (Cl ₂) relative humidity >50%	<0.0005 PPM	<0.001 PPM
	Dry Chlorine (Cl ₂) relative humidity <50%	<0.002 PPM	<0.01 PPM
	Hydrogen chloride (HCl)	<0.0066 PPM	<0.0066 PPM
	Hydrogen fluoride (HF)	<0.001 PPM	<0.005 PPM
	Ammonia (NH ₃)	<1 PPM	<5 PPM
	Ozone (O ₃) or other oxidants	<0.002 PPM	<0.005 PPM
	Nitrogen oxides (NO _x)	<0.05 PPM	<0.1 PPM

Aerosols	Oils	<5 PPB dry air	
Flora and Fauna	None (no presence or risk of growing mold or fungus; negligible risk of damage from rodents, insects or animals)		
Vibration (Stationary, sinusoidal)	<i>Parameter</i>		<i>Maximum value</i>
	Displacement amplitude (2-9 Hz)		0.3 mm (0.039 in)
	Acceleration amplitude (9-200 Hz)		1 m/s ² (0.1 g)
Vibration (Non-Stationary, including shock)	<i>Parameter</i>		<i>Maximum value</i>
	Shock response spectrum type L, peak acceleration \dot{a}		40 m/s ²
	Shock response spectrum type I, peak acceleration \dot{a}		0
	Shock response spectrum type II, peak acceleration \dot{a}		0
Note 1: Solid contaminant and particle examples include, but are not limited to: sand, carbon dust, metal fillings/dust, conductive particles, and organic and inorganic dust and fibers			
Note 2: Mean Value is defined as the average, long-term value			
Note 3: Maximum Value is defined as the maximum value occurring over a period of time of not more than 30 minutes per day			



STOP



Do Not Drill Into Enclosure!

**Warranty will be voided. Cable entry
panels shall be removed from
equipment and vicinity prior to
modification.**

MEPPI technician to remove label after equipment installation.

**WARNING****WARNING 4**

This UPS does not include an AC input circuit breaker (MCCB) to protect the bypass and main input circuit. The AC input circuit breaker (MCCB) is to be field supplied and installed. The recommended circuit breaker (MCCB) specifications are as follows:

Table 2 Rating Of AC Input Circuit Breaker

Capacity (kVA)	Input Voltage (VAC)	Maximum AC Input Rating (AAC)	Recommended Breaker (A)
10	208	30	40
20	208	60	80
30	208	90	110
40	208	120	150
50	208	150	225

AC input and AC output over current protection and disconnect devices shall be field supplied and installed. DC output over current protection and disconnect devices shall be field supplied and installed.

**WARNING****WARNING 5**

This UPS functions with lead acid batteries. If a ▲ is seen, review the supplemental materials for more information about the stored energy system used.

1.2 GENERAL

Your Mitsubishi 1100A Series UPS is designed to provide continuous and clean electrical power to a critical load. In the event of an input power failure, the UPS will supply power to the critical load for the specified battery time.

If the input power is not restored promptly, backup power from the UPS battery permits the orderly shutdown of equipment supported by the UPS. The UPS is simple to startup, operate and maintain.

The 1100A Series UPS is configurable in five (5) kVA capacities: 10, 20, 30, 40 and 50kVA. The specifications for each capacity appear in Section 1.5. The principles of operation described herein are applicable to all configurations.

The UPS cabinet design consists of two types, which are described below:

- a) Battery Built-in Cabinet --- 10 and 20kVA model only
Type: UP1133A-AxxxSU-2
- b) Standard Cabinet --- 10, 20, 30, 40 and 50kVA model (External Battery)
Type: UP1133A-BxxxSU-2

This manual provides an overview of the 1100A Series UPS components and their functions. The appearance and purpose of operator controls and indicators are described with procedures for operation, startup, shutdown and basic maintenance.

1.3 DEFINITIONS

UNINTERRUPTIBLE POWER SUPPLY SYSTEM (UPS) - All components within the UPS Module Cabinet in combination with the batteries (external and/or internal), which function as a system to provide continuous, conditioned AC power to a load. This is sometimes referred to as the "System."

UPS MODULE CABINET - The enclosure which contains Power Converter Module, Bypass Module, Batteries, and the operator controls required to provide specified AC power to a load.

POWER CONVERTER MODULE - The Converter / Charger and Inverter assemblies which, under the direction of the Bypass Module and operator controls, provide specified AC power to a load.

BYPASS MODULE – Assembly which contains Static Transfer Switch, the internal bypass line, and the internal control system. With operator controls, gives directions required to the Power Converter Module to provide specified AC power to a load.

CONVERTER / CHARGER - The UPS components which contain the equipment and controls necessary to convert input AC power to regulated DC power required for battery charging and for supplying power to the Inverter.

INVERTER - The UPS components which contain the equipment and controls necessary to convert DC power from the Converter / Charger, or the battery, to AC power required by the critical load.

STATIC TRANSFER SWITCH - The device that connects the critical load to the bypass line when the UPS module cannot supply conditioned power.

BYPASS LINE - The line which conducts electricity directly from the input power source to the critical load during Maintenance or whenever the UPS is not completely operational.

INPUT POWER - Power provided by the electrical utility company, or auxiliary generator, which is connected to the UPS for supplying the critical load.

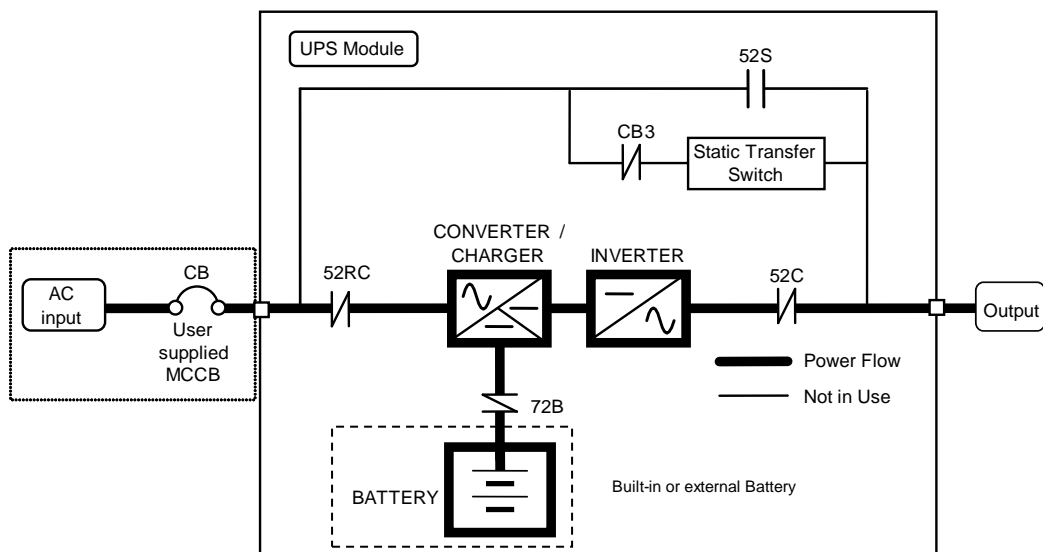
BATTERY - Rechargeable battery strings which supply DC power to the inverter to maintain continuous AC power to the load during AC input power failure conditions.

1.4 OPERATION OVERVIEW

The UPS provides two power paths between the utility source and the critical load. Figure 1 shows the path for normal operation, with the load powered from the inverter. Figure 2 shows the path for bypass operation, with the load supplied through the static bypass line.

A) Normal operation: Load power supplied by UPS inverter.

Figure 1 Single Line Diagram - Normal Operation: Load Powered by UPS Inverter



During normal operation, the path through the UPS inverter is used to power the load.

Referring to Figure 1: The input AC power is converted to DC by the Converter. DC power is utilized to charge the UPS battery and to provide power to the Inverter. The Inverter converts the DC power to clean AC power to supply the critical load.

The conversion - inversion process eliminates any voltage transients or fluctuations existing in the input power before it reaches the critical load.

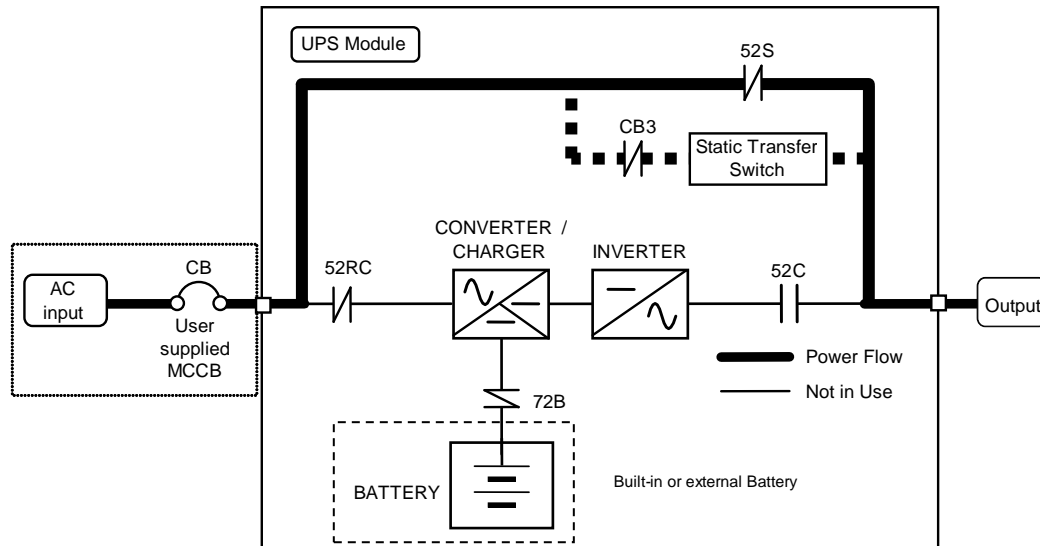


WARNING

WARNING: For the protection of the UPS and cables, the Bypass input circuit breaker (MCCB) is field supplied and field installed (see WARNING 4 on page 1-8).

B) Bypass Operation: Load power supplied through UPS internal static bypass line.

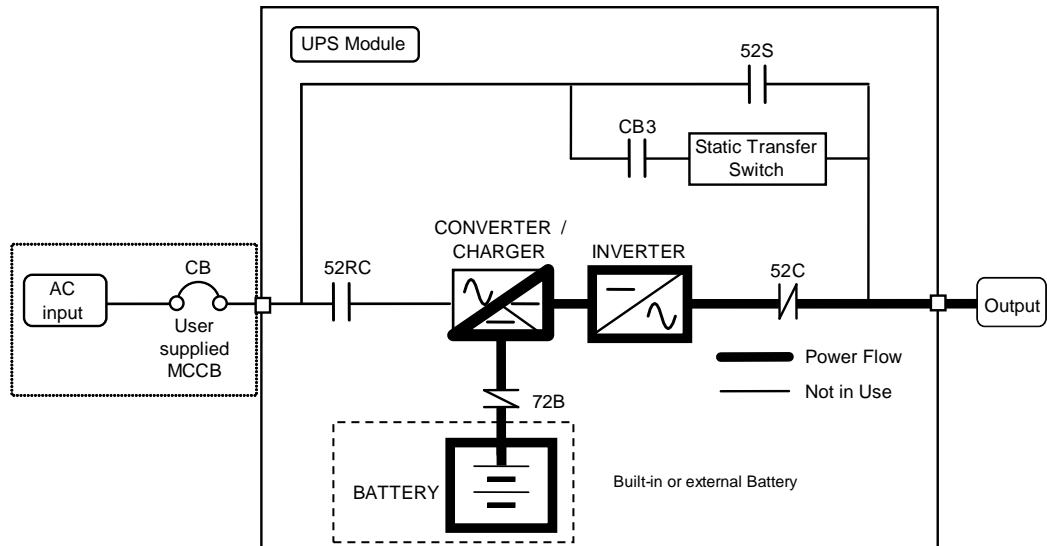
Figure 2 Single Line Diagram - Bypass Operation: Load Fed Through Static Bypass Line



Referring to Figure 2: The Internal bypass line is a hard-wired line through 52S, which supplies the critical load with unconditioned bypass input power. Upon switching to the internal bypass line, the static transfer switch (STS) line through CB3 supplies the power immediately. Then the internal bypass line through 52S supplies the power. In the event of switching to the bypass line, the power to the critical load will be uninterrupted. The purpose of this internal bypass line is to route power to the critical load while the UPS module (converter and inverter) is de-energized, and during startup before the system is operating on the UPS module.

In the event of a load overcurrent, the UPS transfers to bypass without interruption to the critical load.

The internal control system determines the operation of the two paths, with the load powered by the inverter being the normal operation.

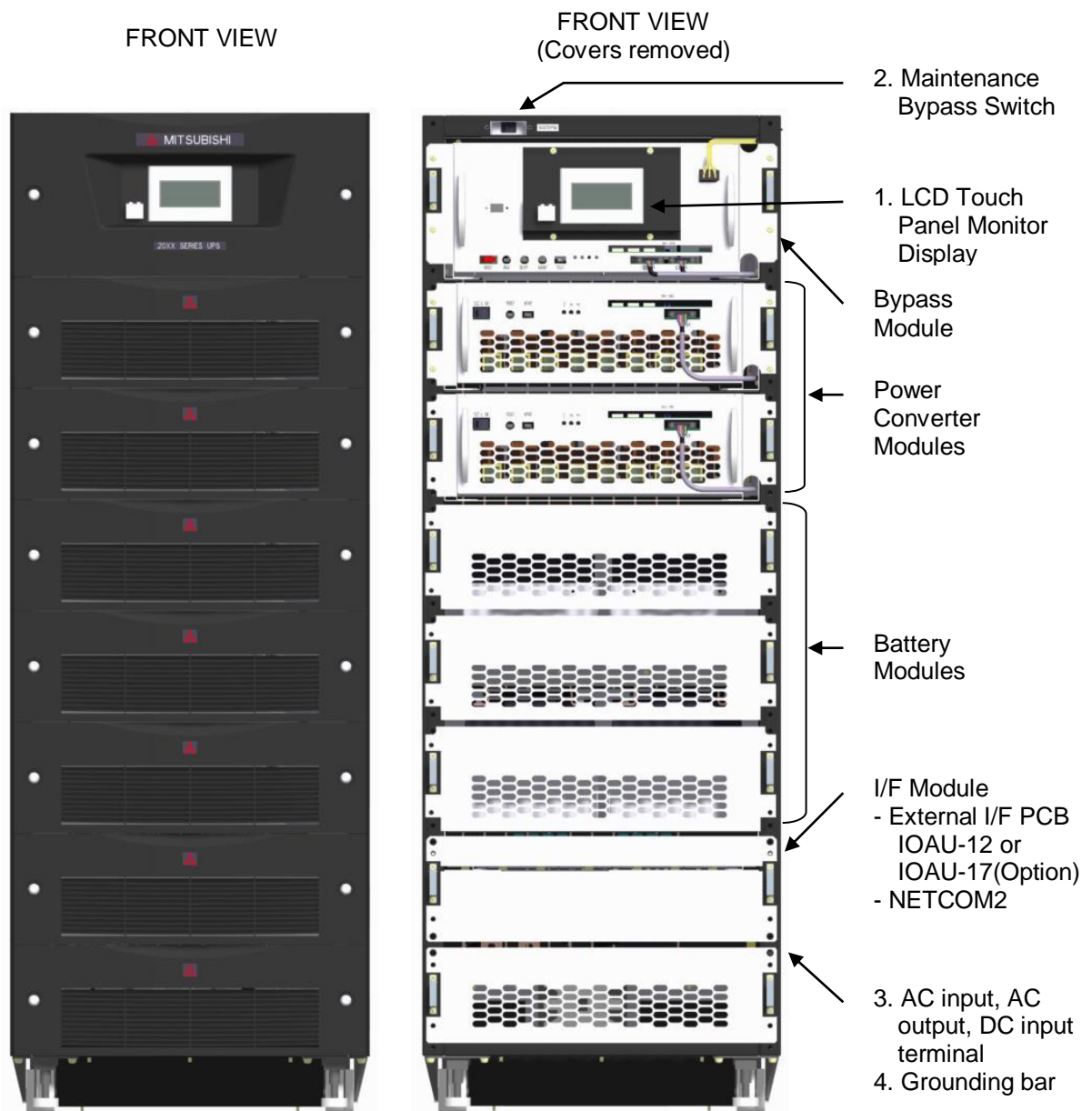
C) Emergency Operation: Load power supplied by UPS battery.
Figure 3 Single Line Diagram - Emergency Operation


Referring to Figure 3: In the event of an AC input source failure or interruption, the UPS converter will de-energize and the UPS battery will immediately discharge and supply DC power to the inverter. This will maintain continuous AC power to the load. This operation will continue until:

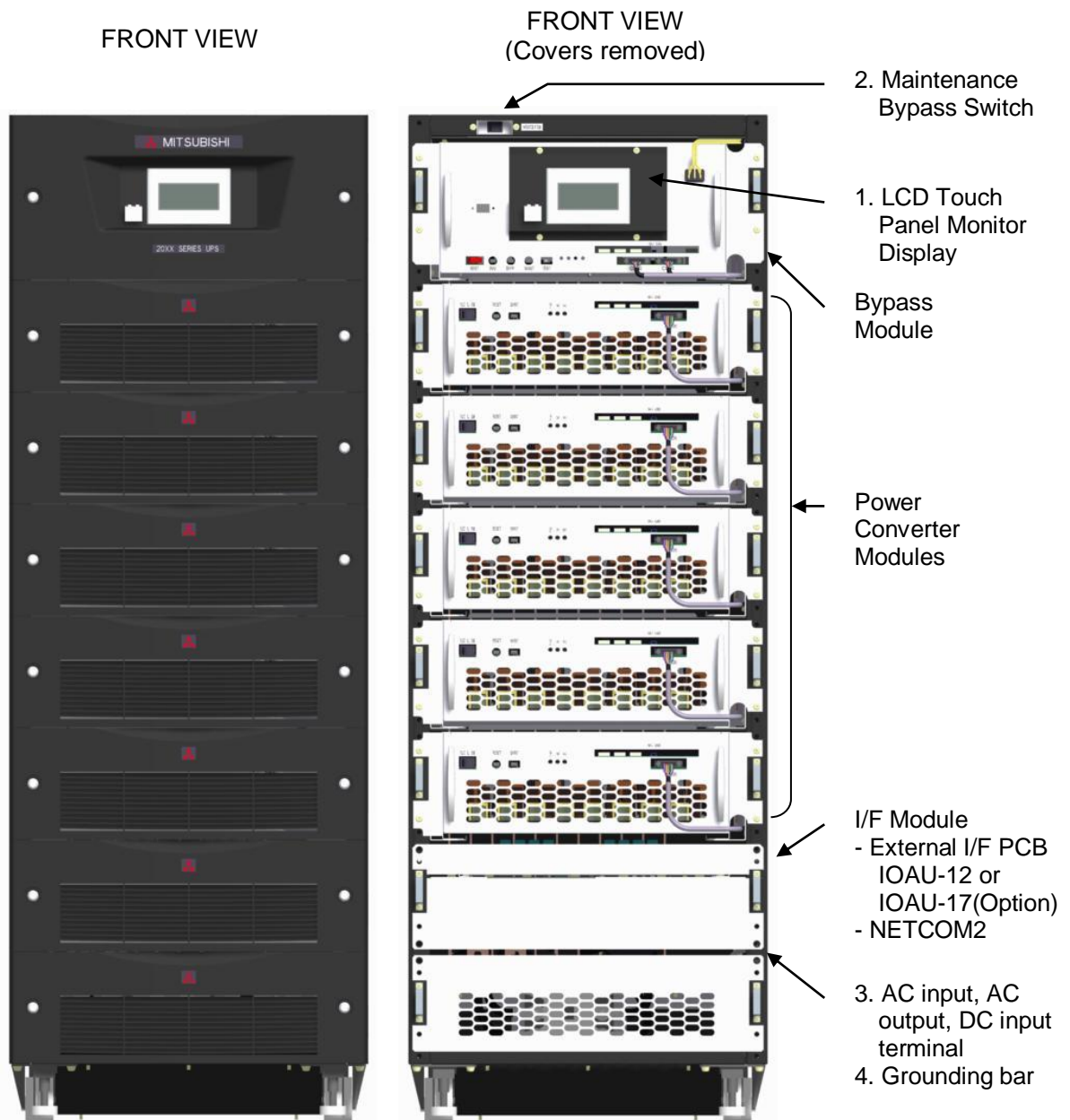
- a) The battery capacity expires and the inverter turns off, or
- b) The input power is restored, after which the converter will simultaneously power the inverter and critical load and recharge the batteries.

A fully charged battery will provide power for the specified time at the rated load, or longer at a reduced load.

When power is restored after a low battery shutdown, the UPS converter automatically restarts operation, the charger recharges the batteries and the Inverter is automatically restarted without operator intervention. The load is also automatically assumed by the inverter without operator intervention.

Figure 4 UPS Parts Location (10, 20kVA only) --- Battery Built-In Cabinet Model


* Items 3 and 4 (AC input, AC output, DC input terminal, and Grounding Bar) are not shown in Figure 4 (refer to Figure 40).

Figure 5 UPS Parts Location (10, 20, 30, 40, 50kVA) --- Standard Cabinet Model


* Items 3 and 4 (AC input, AC output, DC input terminal, and Grounding Bar) are not shown in Figure 5 (refer to Figure 40).

Figure 6 UPS Parts Location (Bypass Module)

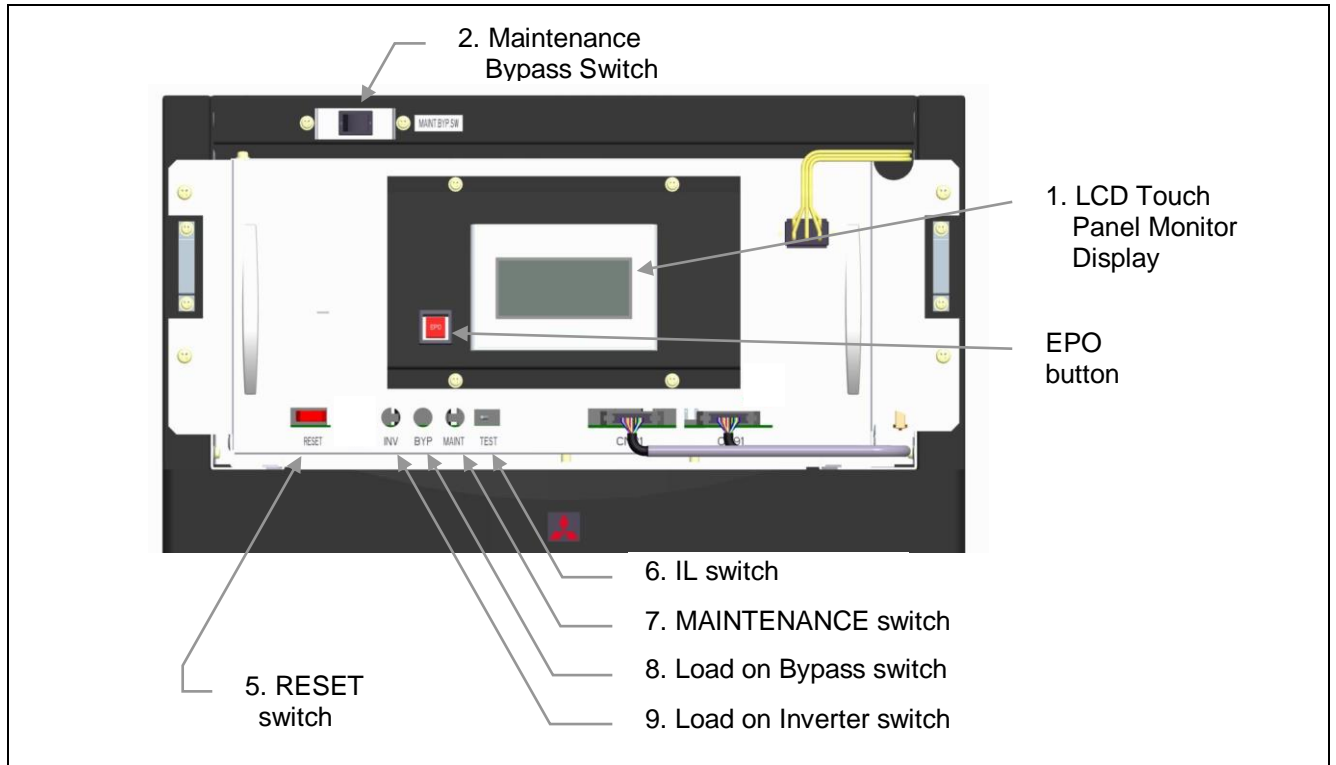
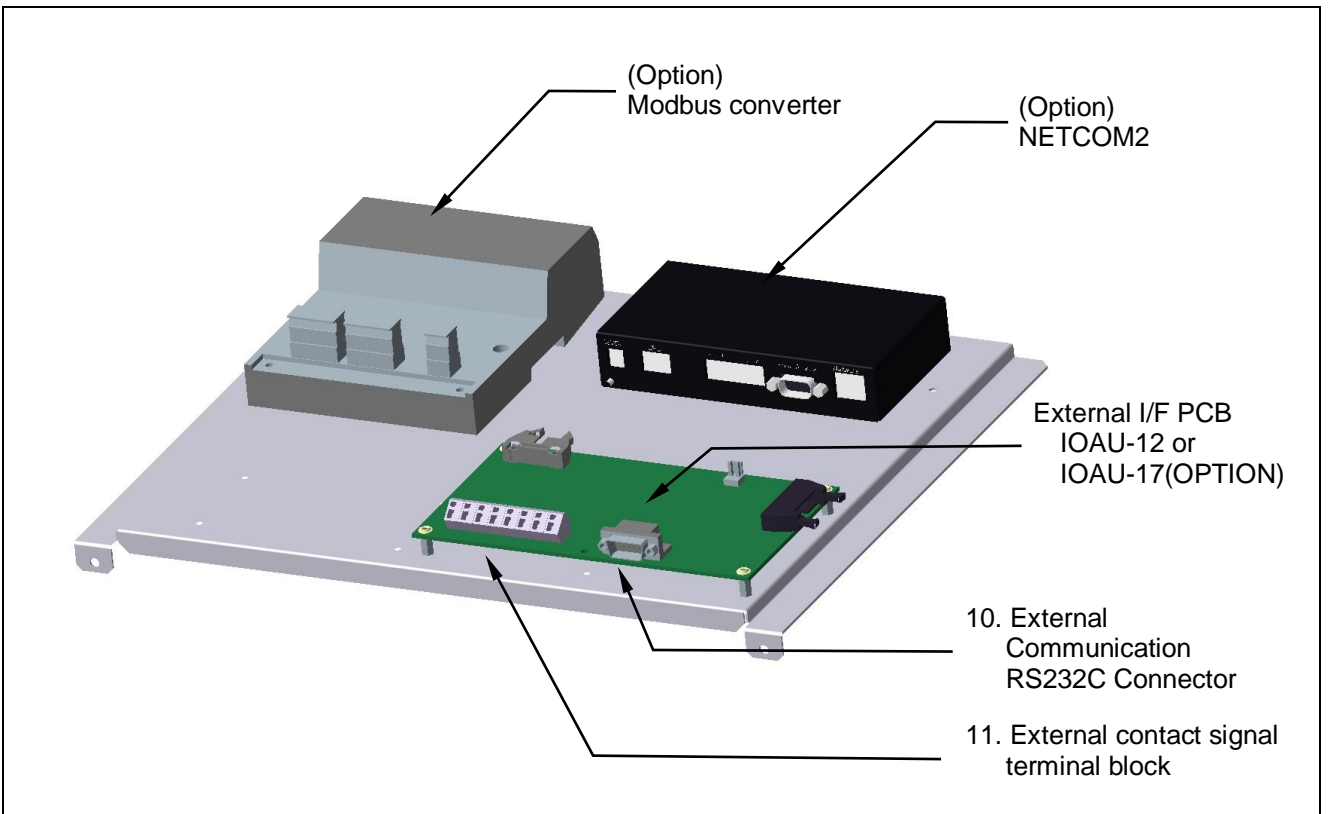


Figure 7 External I/F Module



Description of UPS parts, referred to in Figure 4 to Figure 7:**1. LCD Touch Panel Monitor Display**

The Liquid Crystal Display (LCD) touch panel display indicates power flow, measured values and fault and error messages via user selectable display screens.

Refer to Figure 8 for details.

2. Maintenance Bypass Switch

This switch activates the bypass power supply for emergency reasons if the UPS is turned off.

3. AC input, AC output, DC input terminal

Refer to Figure 40 for details

4. Grounding Bar (E)**5. "RESET" switch (FOR SERVICE PERSONNEL ONLY)**

This switch resets errors resulting from alarm conditions.

6. "IL" switch (FOR SERVICE PERSONNEL ONLY)

This switch inhibits the start of the UPS.

7. "MAINTENANCE" switch (FOR SERVICE PERSONNEL ONLY)

This switch sets the UPS menu parameters.

8. "LOAD ON BYPASS" switch (FOR SERVICE PERSONNEL ONLY)

This switch is used to transfer the UPS from inverter to static bypass for maintenance purposes. Do not use this under normal operation. Transfers will be locked-out if the bypass voltage is more than $\pm 10\%$ of the nominal. Uninterrupted switching is made at the time of synchronous operation. Switching is impossible at the time of asynchronous operation.

9. "LOAD ON INVERTER" switch (FOR SERVICE PERSONNEL ONLY)

This switch is used to transfer the UPS from static bypass to inverter for maintenance purposes.

10. External communication RS232C connector (Figure 7)**11. External contact signal terminal block (Figure 7)**

This terminal block is used to connect contact signal input/output lines to and from external dry contacts. Refer to Figure 28 and Figure 29 for details.

1.5 SPECIFICATIONS

The UPS name plate displays the rated kVA and nominal voltages and currents.

The nameplate is located on the top of the UPS cabinet.

Table 3 Power Specifications

Rated output Power	Input voltage 3 ph / 4 wire	Output voltage 3 ph / 4 wire
10kVA / 9kW 20kVA / 18kW 30kVA / 27kW 40kVA / 36kW 50kVA / 45kW	120V / 208V	120V / 208V

Table 4 UPS Module Cabinet Information (Battery Built-in Cabinet model)

UPS (kVA)	CABLE ENTRY	WIDTH (in/mm)	DEPTH (in/mm)	HEIGHT (in/mm)	WEIGHT (lb./kg)	HEAT REJECTION (kBTU/h)
10	BOTTOM	19.7 / 500	27.0 / 685	55.2 / 1400	685* / 310*	2.6
20	BOTTOM	19.7 / 500	27.0 / 685	55.2 / 1400	730* / 330*	5.1

*: Including Batteries

Table 5 UPS Module Cabinet Information (Standard Cabinet model)

UPS (kVA)	CABLE ENTRY	WIDTH (in/mm)	DEPTH (in/mm)	HEIGHT (in/mm)	WEIGHT (lb./kg)	HEAT REJECTION (kBTU/h)
10	BOTTOM	19.7 / 500	27.0 / 685	55.2 / 1400	290 / 130	2.6
20	BOTTOM	19.7 / 500	27.0 / 685	55.2 / 1400	335 / 150	5.1
30	BOTTOM	19.7 / 500	27.0 / 685	55.2 / 1400	380 / 170	7.7
40	BOTTOM	19.7 / 500	27.0 / 685	55.2 / 1400	420 / 190	10.4
50	BOTTOM	19.7 / 500	27.0 / 685	55.2 / 1400	465 / 210	13.0

Table 6 Detail of Specifications* ▲

*In case of Battery Built-in Cabinet model.

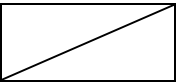
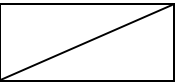
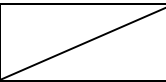
Type	UP1133A-A10 3SU-2 UP1133A-B10 3SU-2	UP1133A-A203S U-2 UP1133A-B203S U-2	UP1133A-B303S U-2	UP1133A-B403S U-2	UP1133A-B503S U-2
Rated Output kVA	10	20	30	40	50
Rated Output kW	9	18	27	36	45
AC INPUT CHARACTERISTICS					
Configuration	3-phase, 4-wire, plus ground				
Voltage	120/208 V +15% ~ -30%				
Frequency	60 Hz +/- 10%				
Reflected Current THD	4% typical at 100% load; 7% typical at 50% load				
BATTERY					
Type	VRLA				
Ride Through (at 100% load)	18min. *	5min. *			
Nominal Voltage	288 Vdc				
Minimum Voltage	240 Vdc				
Number of Cells	144 cells				
AC OUTPUT					
Configuration	3-phase, 4-wire, plus ground				
Voltage	120/208 V				
Voltage Stability	+/-1%				
Frequency	60 Hz				
Frequency Stability	+/-0.01% in free running mode				
Power Factor	0.9 nominal				
Power Factor range	0.9 ~ 1.0 lagging (within output kW rating)				
Voltage THD	2% typical THD at 100% linear load 5% typical THD at 100% non-linear load				
Transient Response	+/-3% typical at 100% load step +/-1% typical at loss/return of AC power +/-5% typical at load transfer to/from static bypass				
Transient Recovery	16.7 ms				
Voltage Unbalance	+/-2% typical at 100% unbalanced load				
Voltage Phase Angle Displacement	+/-1deg. typical at 100% load				
Inverter Overload	105% to 125% for 60 seconds; 126% to 150% for 30 seconds				
System Overload	1000% for 1 cycle (with bypass available)				
Crest Factor Capabilities	2.5 : 1				
ENVIRONMENTAL					
Cooling	Forced Air				
Operating Temperature	41 deg F ~ 95 deg F (5 deg C ~ 35 deg C). Recommended 68 deg F ~ 77 deg F (20 deg C ~ 25 deg C)				
Relative Humidity	5% ~ 95% Non-Condensing				
Altitude	Varies with model				
Location	Temperature-controlled, indoor area free of conductive contaminants				
Paint Color	Munsell N1.5 (Black)				

Table 7 Rating of Contactors and Fuses ▲

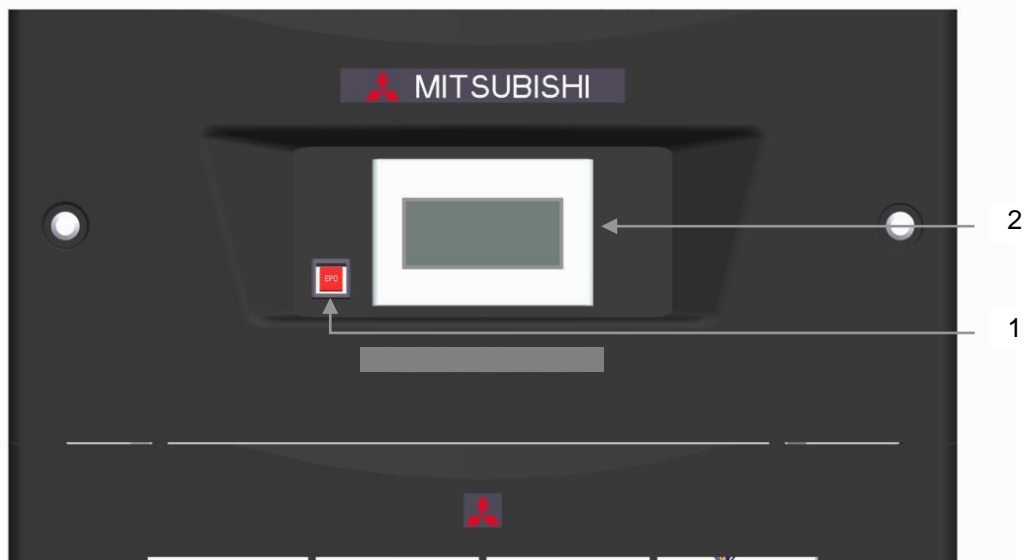
Component	Description	Component Rating @ 208V, 3-phase, 60 Hz					
		UPS Rating (kVA)	10	20	30	40	50
CB3	Static Bypass Input Contactor		80A	80A	80A	80A	80A
52S	Static Bypass Contactor		150A	150A	150A	150A	150A
F6,F7,F8	AC Input Fuse		660V / 60A				
F4,F5	Battery Input Fuse		660V / 60A				
F9,F10,F11	AC Output Fuse		660V / 60A				
F2,F3	Control Power		250V / 2A				
F1	Control Power		500V / 5A				
	Internal Battery Input Fuse		500V / 150A				

▲ ***For other stored energy systems, refer to the supplement..***

2 OPERATOR CONTROLS AND INDICATORS

The 1100A Series operator controls and indicators are located as follows:

Figure 8 Operation/Display Panel (Front panel)



2.1 EMERGENCY POWER OFF BUTTON (1)

When activated, the Emergency Power Off (EPO) function shuts down the UPS module. The critical load will also lose power and shutdown. The EPO function can be performed both locally or remotely.

2.2 LIQUID CRYSTAL DISPLAY (2)

The Liquid Crystal Display (LCD) touch panel indicates power flow, measured values, operational guidance, data records and error messages. The LCD panel has a back-light, which facilitates viewing in different ambient lighting conditions.

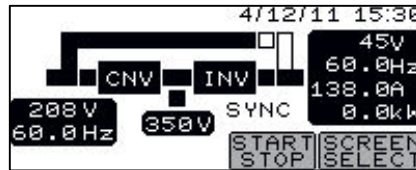
2.2.1 MENU

Refer to Figure 27 for the SCREEN MENU tree.

A) MAIN MENU (Figure 9)

The LCD panel indicates power flow and measured values, while also operating the start/stop function. The LCD panel also allows the user to verify the status and operation of the UPS Module.

Figure 9 Main Screen



The following will be displayed when the START/STOP key on the SCREEN SELECT MENU (Figure 12) is pressed (in the **OPERATION MENU**):

1) Startup/Shutdown Guidance (Figure 10, Figure 11)

This display indicates the Startup and Shutdown guidance for the UPS system. If this operation is PIN protected, the user is required to enter the security PIN before the screen can be accessed.

When in remote mode, the message "REMOTE operating model" will appear on this screen. The user cannot operate the start and stop functions without changing the setup from remote mode to local mode.

When the bypass voltage is abnormal, the message "Bypass voltage abnormal" will appear.

- **Stop:** When the bypass voltage is abnormal, the user cannot transfer from inverter to bypass line.

Figure 10 Startup Guidance



Figure 11 Shutdown Guidance

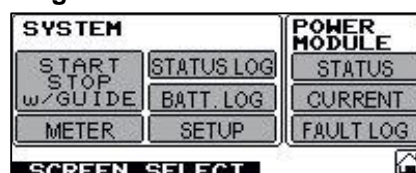


Follow Startup/Shutdown guidance accordingly.

2) SCREEN SELECT MENU (Figure 12)

This screen shows all screen menus.

Figure 12 Screen Select Menu

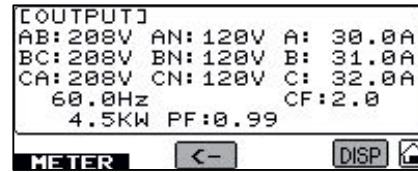
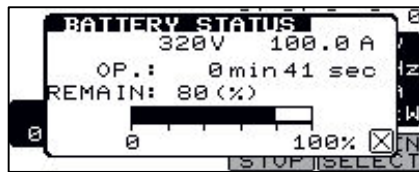
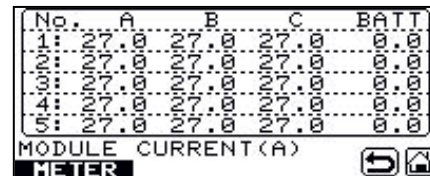


B) MEASUREMENT MENU (Figure 13 – Figure 16)

The following will be displayed when the METER key on the SCREEN SELECT MENU is pressed. This screen displays details of measured values for the input and output. During battery operation, “remaining battery power” and “run time” are also displayed.

When the CURRENT key on the SCREEN SELECT MENU is pressed, the output current of each individual module is displayed.

Figure 13 Input Values

Figure 14 Output Values

▲ Figure 15 Measurement During Battery Operation

Figure 16 Each Power Converter Module Output Current


▲ For other stored energy systems, refer to the supplement..

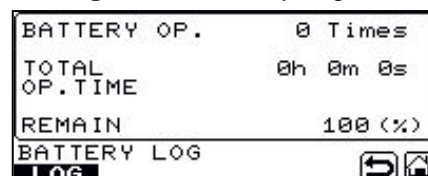
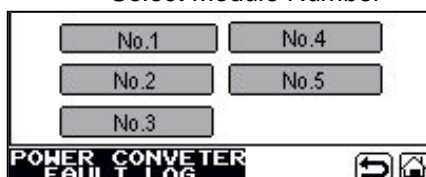
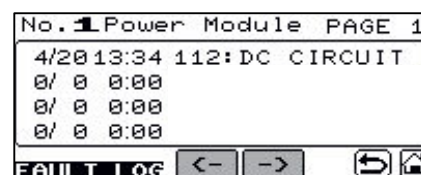
C) LOG (Figure 17– Figure 20)

Up to 50 condition/operation records will be displayed by pressing the STATUS LOG icon on the SCREEN SELECT MENU. Press “→” or “←” button for page turning.

Pressing the BATT.LOG icon will display “number of battery operations” and “cumulative battery operation time.”

By pressing the F.LOG icon, up to 20 power converter module failure records will be displayed. Press “→” or “←” button for page turning.

Figure 17 Status Log

Figure 18 Battery Log

Figure 19 Power Converter Failure Log
Select Module Number

Figure 20 Power Converter Failure Log


D) SETUP MENU (Figure 21, Figure 22)

The following will be displayed when the SETUP key on the SCREEN SELECT MENU is pressed.

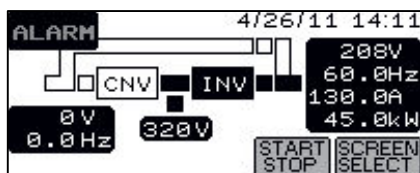
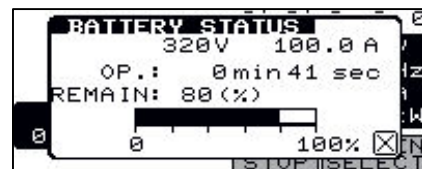
This screen prompts the user to select: (Figure 21) whether the start & stop operation will be performed by local or remote operation; or (Figure 22) time & date adjustment.

Figure 21 Remote/Local Operation Select

Figure 22 Date & Time adjustment

2.2.2 INPUT POWER FAILURE (Figure 23, Figure 24)

During an input power failure, the UPS inverter will be powered by the UPS batteries. The following will be displayed on the main and measurement screen: “indication of battery operation” and “remaining battery life.”

▲ Figure 23 Main Screen
(Battery Operation)

Figure 24 Measurement Screen


The LCD will display a “battery low voltage” message when the battery capacity is near depletion. The “End of Battery Discharge” announcement is displayed when the battery end voltage is reached. At this time, the inverter will perform an electronic shutdown to prevent battery loss of life, which is typical from extreme deep discharge conditions. When the input power is restored, the inverter will automatically restart to power the load and the batteries will be simultaneously recharged.

▲ For other stored energy systems, refer to the supplement..

2.2.3 FAULT INDICATION (Figure 25)

An ALARM icon will appear on the main menu (top left) when a UPS failure condition has occurred.

Figure 25 Main Screen (Fault Indication)

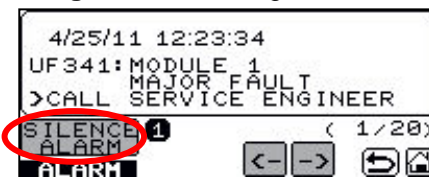


The following will be displayed when the ALARM icon on the main menu is pressed:

1) ALARM MESSAGE (Figure 26)

The display shows a fault code, a description of the fault and a guidance of what action is to be taken by the user. A maximum of 20 faults are displayed at one time.

Figure 26 Message Screen



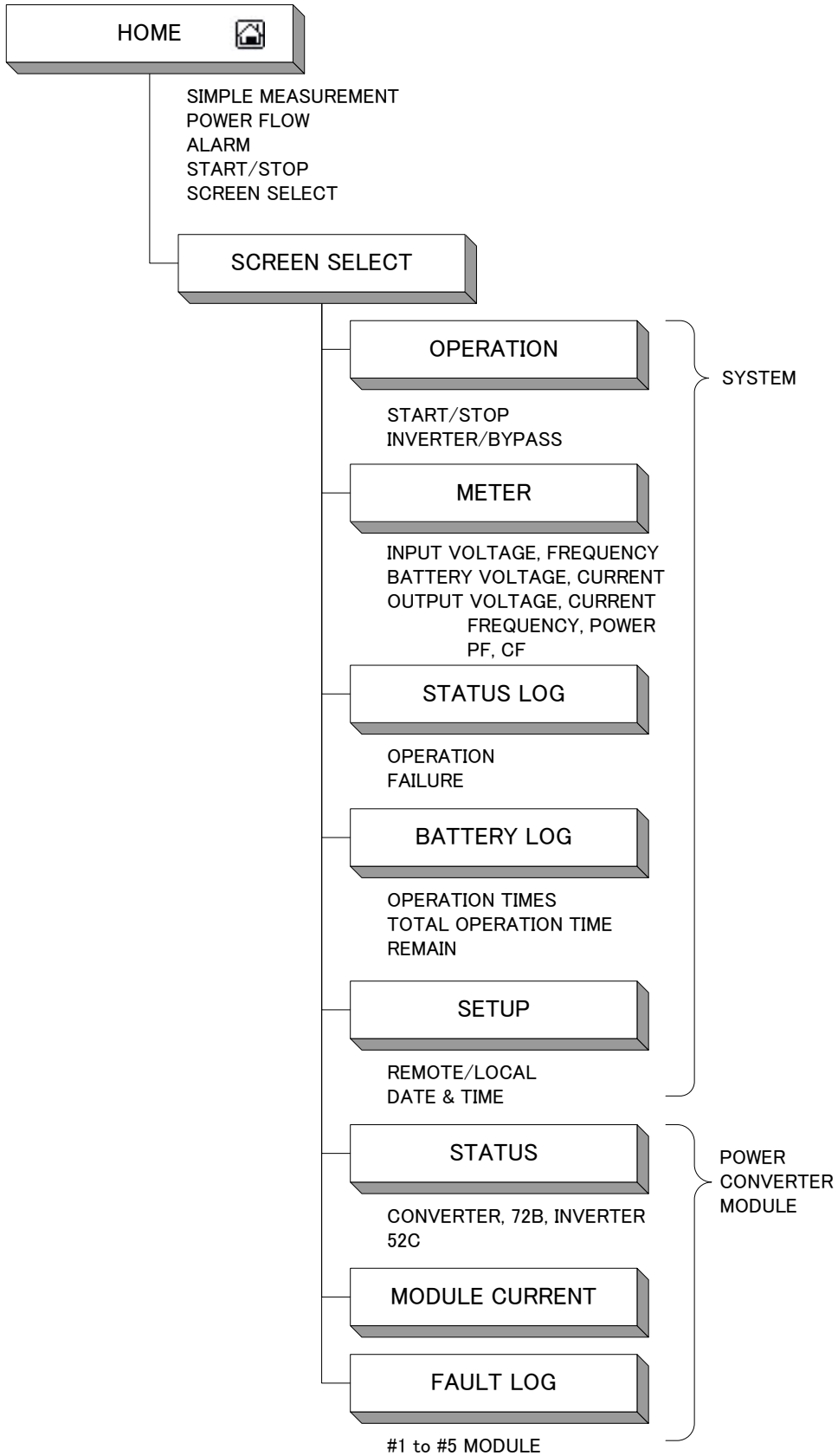
2) SILENCE ALARM (Figure 26)

The circled icon will appear when a failure occurs. The audible alarm announcing the failure can be silenced by pressing this icon.

3) MODULE NUMBER

This icon will appear when the module failure occurs. The module fault detail will be displayed when this icon is pressed (Figure 20).

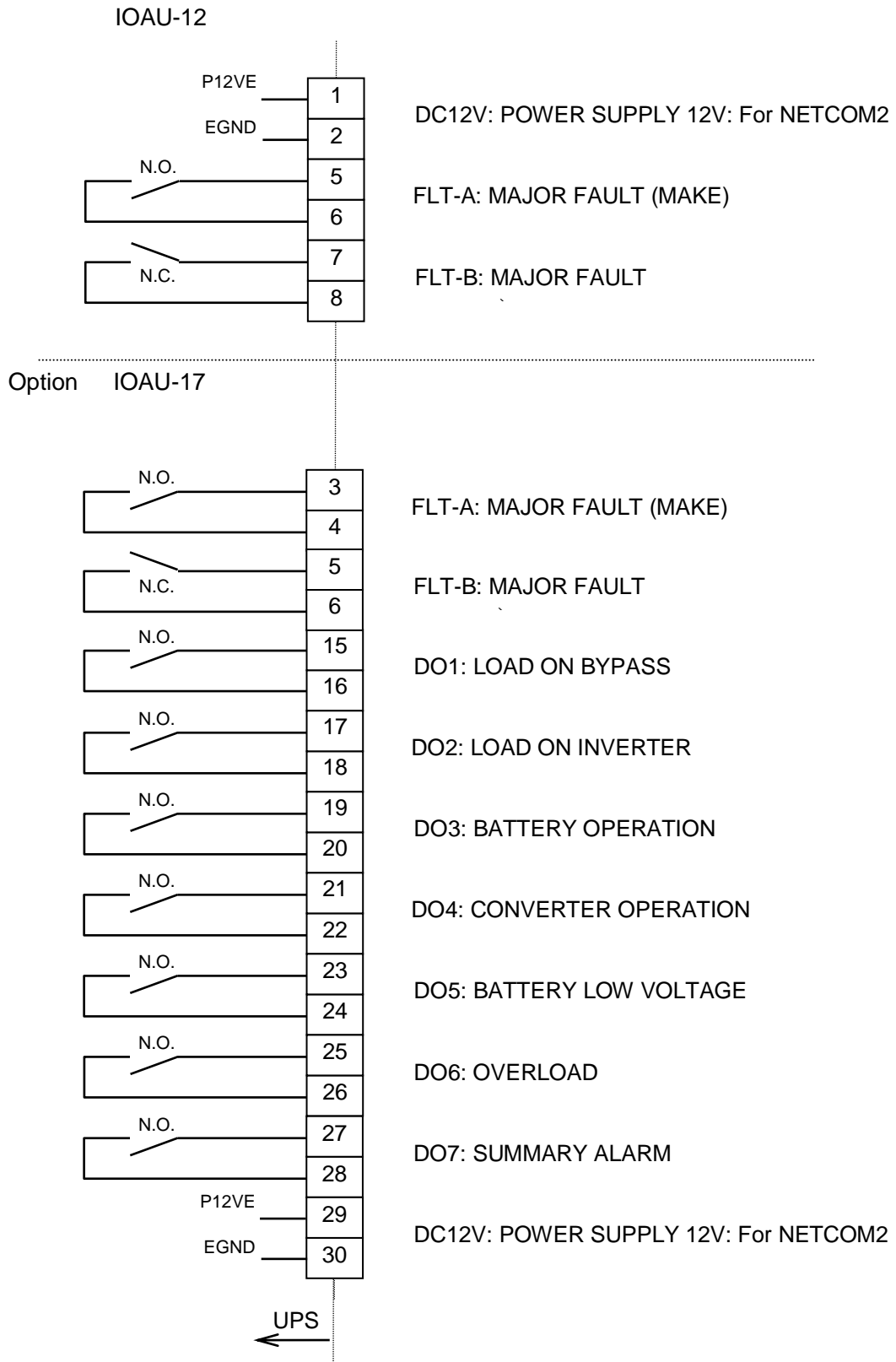
Figure 27 MENU Tree



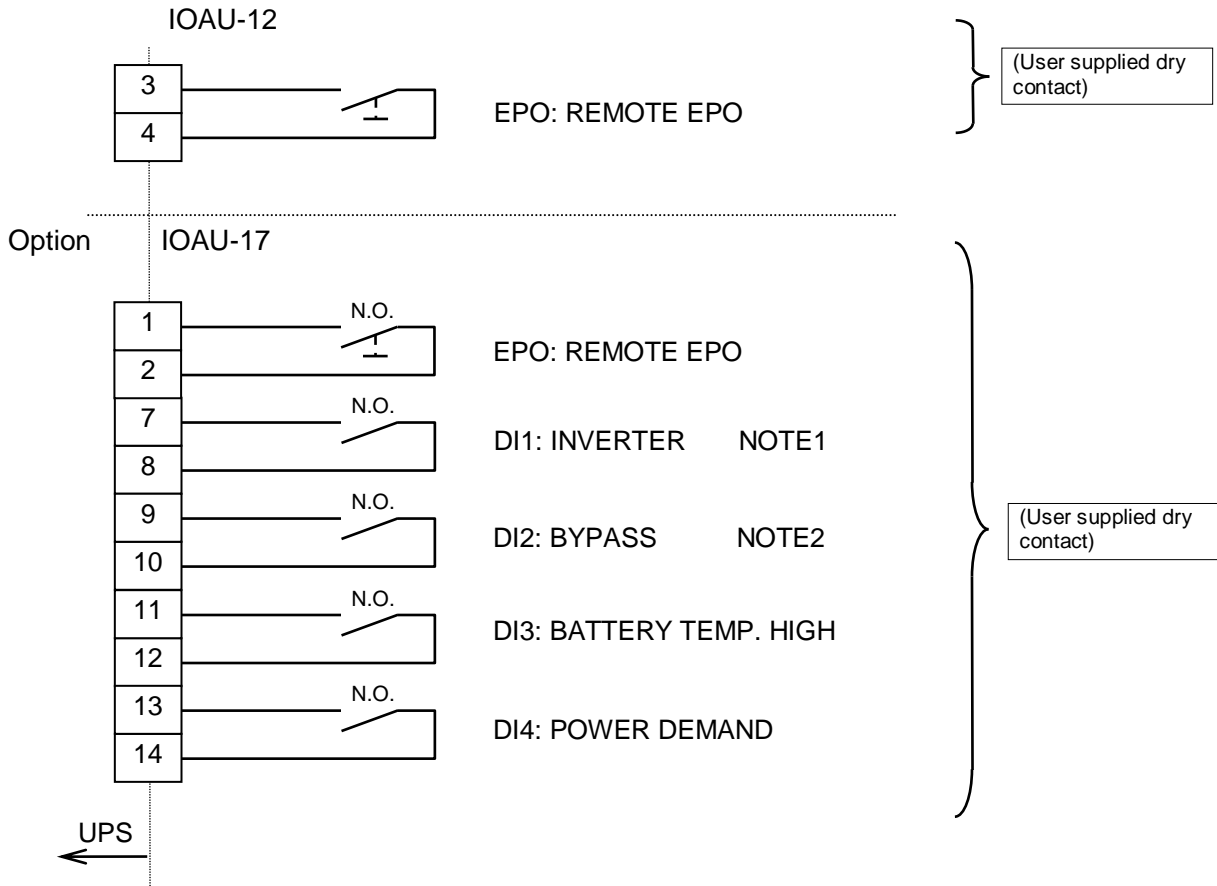
2.3 EXTERNAL SIGNAL TERMINAL BLOCK

The UPS is equipped with a series of input/output terminals for external annunciation of alarms and for remote access of certain UPS functions. The layout of these terminals are shown in Figure 28 and Figure 29 with a functional description of the input/output ports. Optional output ports DO1 to DO7 are user programmable, but are set to factory default, and are also shown in Figure 28.

Optional input ports DI1 to DI4 are user programmable, but are set to factory default, and are also shown in Figure 29.

▲ Figure 28 External Signal Terminal Block (NEC Class2)


▲ For other stored energy systems, refer to the supplement..

▲ Figure 29 External Signal Terminal Block (NEC Class2)


NOTE 1: Remote transfer operation from BYPASS to INVERTER.

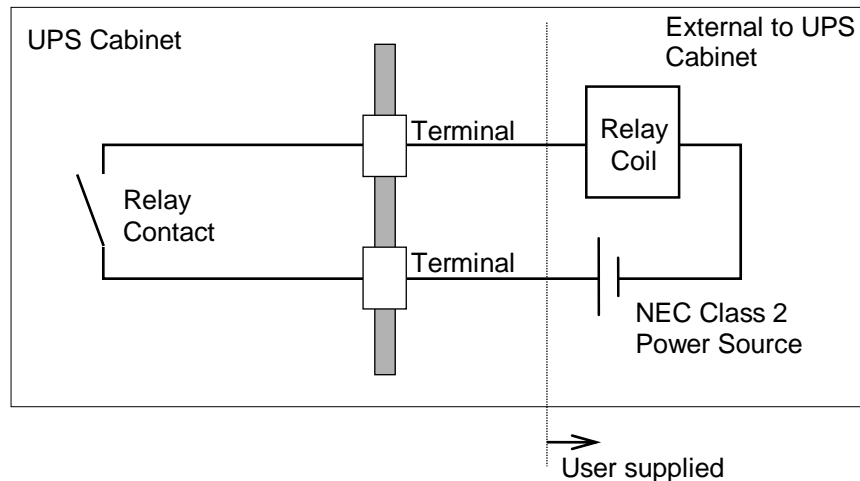
NOTE 2: Remote transfer operation from INVERTER to BYPASS.

UPS direct operation is required for INVERTER START/STOP control.

▲ For other stored energy systems, refer to the supplement..

A) Output Contacts (for external alarm annunciation)

Output contacts consist of form "A" dry type contacts. The rated capacity of all output contacts is NEC Class2 (30Vdc/1Adc). All dry contacts should be operated at their rated values or lower. Figure 30 illustrates a typical installation. The external relay can also be a lamp, LED, computer, etc.

Figure 30 Control Wiring for External Contacts

Details of output alarm contacts: IOAU-12

Terminals 5 to 6 "**Major fault (make)**" contact

Activated when a major fault has occurred with the system.

Terminals 7 to 8 "**Major fault (break)**" contact

Activated when a major fault has occurred with the system.


NOTE

NOTE: The UPS is equipped with a selectable output contact feature.

The above alarms are the default settings.

Contact **MITSUBISHI ELECTRIC POWER PRODUCTS, INC** at
1-800-887-7830 for setup information.

B) Input Contacts (for remote access of UPS)

External contacts are provided by the user of the UPS system. The terminal voltage at the UPS is 24Vdc. Provide external dry contact accordingly.

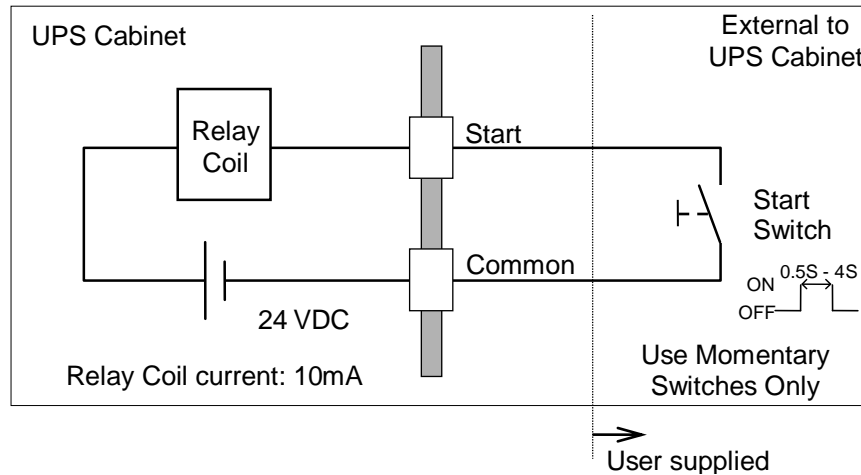

CAUTION

CAUTION: Do not apply voltages to remote access input terminals.

Damage to UPS may result.

Refer to Figure 31 for a typical wiring configuration. Although this figure applies to the remote start/stop terminals, the same wiring arrangement is used for “emergency stop,” “power demand,” and “battery temperature high.”

Figure 31 Remote "Start" Contact Connections



Details of input contacts for remote access: IOAU-12

Terminals 3 to 4 "Remote EPO" contact input

Used to perform a remote UPS Emergency Power Off (EPO).

The load will be dropped.



NOTE

NOTE: The UPS is equipped with a selectable input contact item. The above items are the default settings. Contact MITSUBISHI ELECTRIC POWER PRODUCTS, INC at 1-800-887-7830 for setup information.



CAUTION

CAUTION: In all cases, a switch having a protective cover is recommended to reduce the possibility of accidental operation.

2.4 EXTERNAL COMMUNICATIONS

External communications are provided using Lookups. Refer to the Lookups technical manual U-ENM00017 for details.

3 INSTALLATION AND OPERATION

3.1 UPS COMPONENTS

Refer to Table 8 for list of component weights.

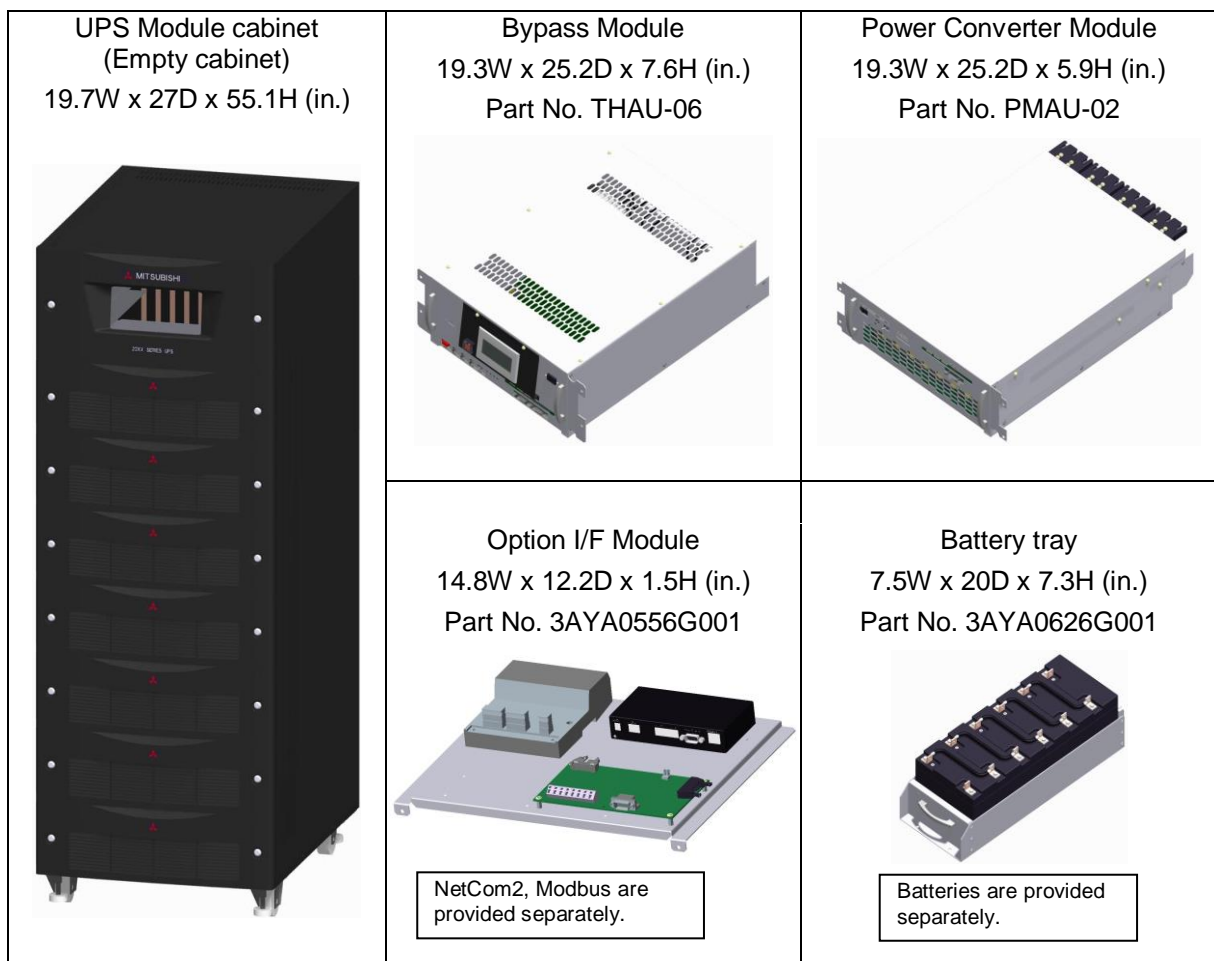


NOTE

Table 8 List of UPS component weights

Component		Weight (lb.)
UPS Module cabinet only	Battery Built-in cabinet	245
	Standard cabinet	215
Power Converter Module		45
Bypass Module		25
Option I/F Module		5
Battery tray	Including six(6) Batteries	95
	Tray only	5

Figure 32 UPS Components



3.2 TRANSPORTATION AND INSTALLATION

Table 9 How to Transport and Install the System

Transportation	Installation
Transport unit with a forklift.	Pull out the UPS cabinet, as shown in Figure 33. Fix the UPS unit in place using the four (4) leveling feet. Using the two (2) brackets (with pre-drilled hole (0.47" diameter)), anchor the UPS using appropriate hardware (not provided).



NOTE

NOTE: Do not transport in a horizontal position. Cabinets should be maintained upright within +/- 15° of the vertical during handling.

3.3 HANDLING

The UPS is shipped in export packaging. Remove the UPS from the package only when it is ready for installation.


STOP

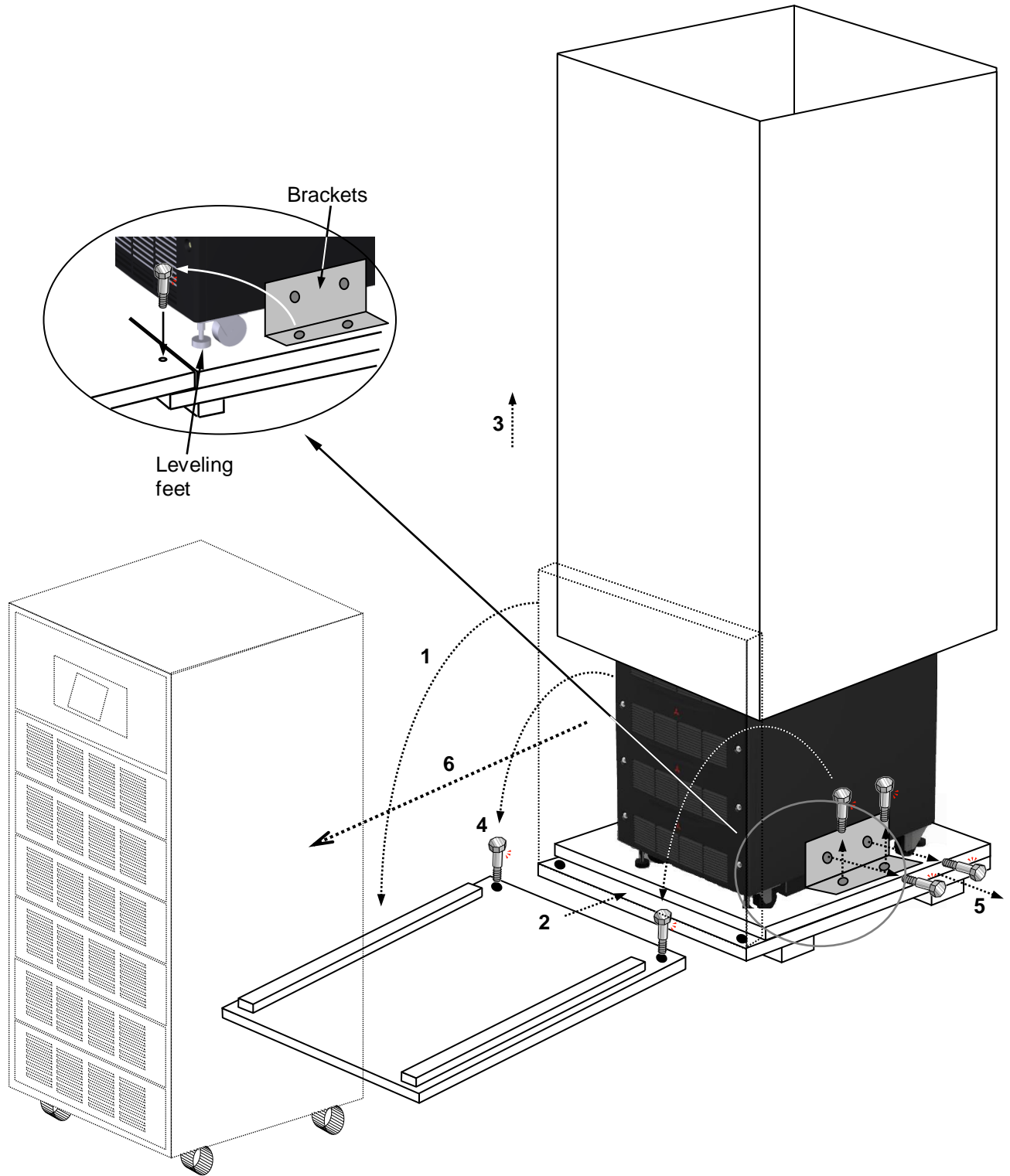


**Do Not Drill
Into Enclosure!**

Warranty will be voided. Cable entry panels shall be removed from equipment and vicinity prior to modification.

MEPPI technician to remove label after equipment installation.

Figure 33 Handling



3.4 INSTALLATION PROCEDURE

A) Note the load tolerance of the floor.

Refer to Table 10 and 11 for a list of UPS weights:



NOTE

Table 10 List of UPS Weights (Battery Built-In Cabinet Model)

UPS Capacity (kVA)	10	20
Weight (lb.)	685*	730*

*: *Includes Batteries*

Table 11 List of UPS Weights (Standard Cabinet Model)

UPS Capacity (kVA)	10	20	30	40	50
Weight (lb.)	290	335	380	420	465

B) Minimum clearance required for ventilation:

Right side 1.0" (25 mm) (not required when sidecars are used)
 Left side 1.0" (25 mm) (not required when sidecars are used)
 Back side 8.0" (203 mm) (refer to Figure 33 for Battery Built-in Cabinet Model)
 Top side 16.0" (406 mm)

C) Space requirement for routine maintenance:

Allow for the following space at the time of installation.

Front 31.5" (800 mm)
 Sides 1.0" (25 mm)
 Rear 8.0" (203 mm)
 Top side 16.0" (406 mm)

Figure 34 Clearance For Ventilation And Maintenance

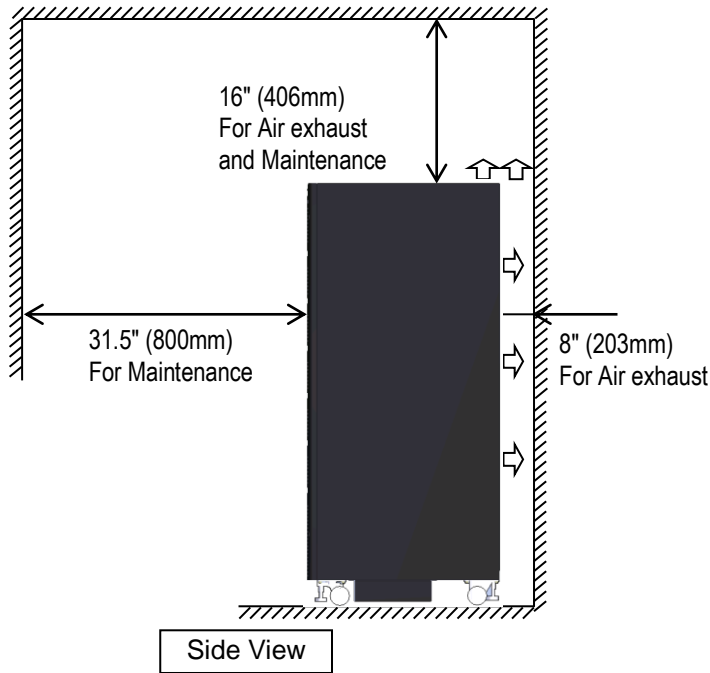
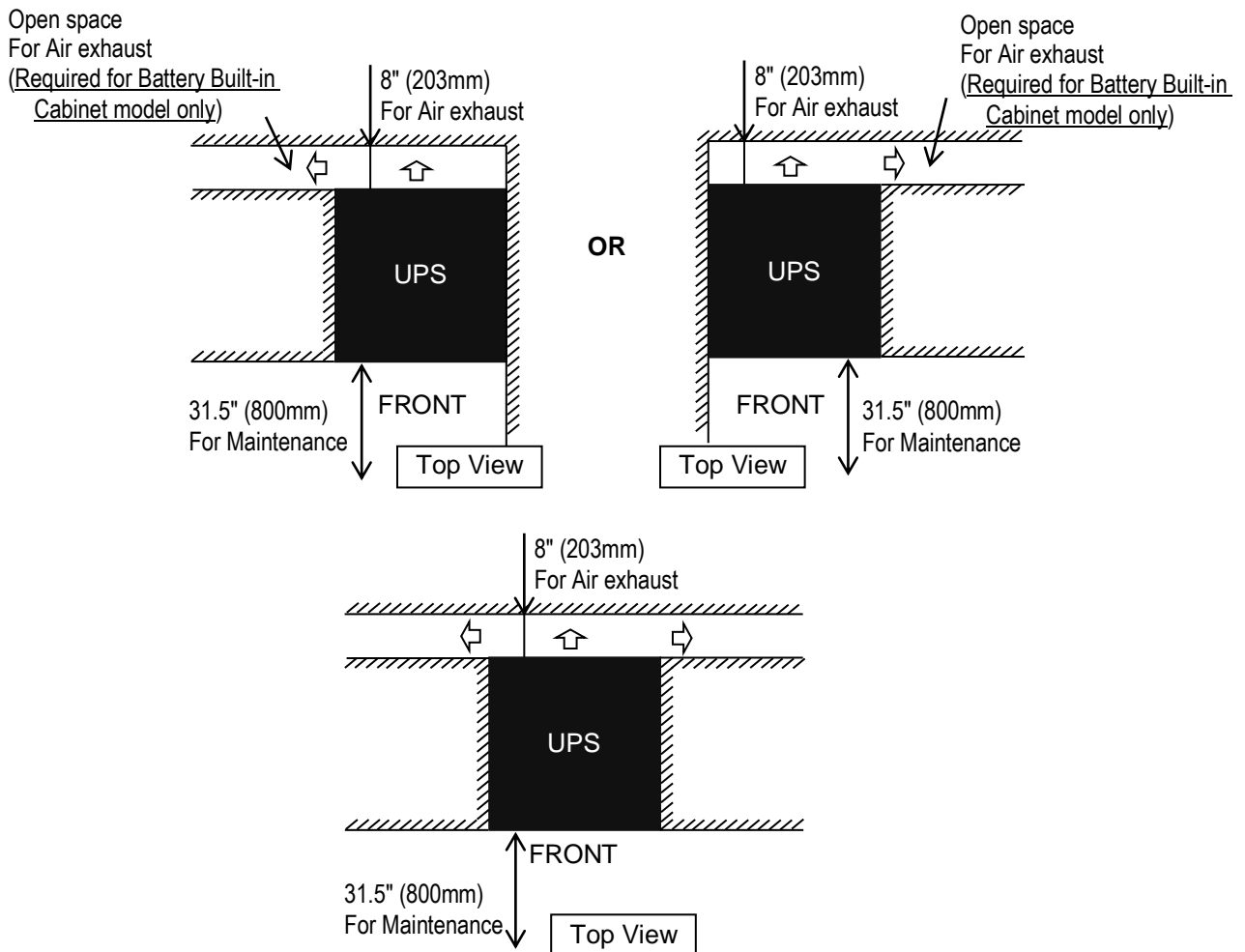


Figure 35 Rear Clearance for Ventilation and Maintenance for Battery Built-In Cabinet Model



▲ Internal Battery (Battery Built-In Cabinet Model)

Please refer to the following when installing and maintaining the batteries:



1. Servicing of batteries should be performed or supervised by personnel knowledgeable of the batteries and the required precautions. Keep unauthorized personnel away from the batteries.
2. When installing or replacing the batteries, install or replace with the same number and type per Table 12.

Table 12 Type and Number of Battery

UPS Capacity	Type	Manufacturer	Number
10kVA	NPX-80FR	EnerSys	24
20kVA	NPX-80FR	EnerSys	24



3. CAUTION - Do not dispose the battery or batteries in fire. The battery may explode.
4. CAUTION - Do not open or mutilate the battery or batteries. Released electrolytes are harmful to the skin and eyes. It may be toxic.
5. CAUTION - A battery can present a risk of electrical shock and high short circuit currents. The following precautions should be observed when working on batteries:
 - a) Remove watches, rings, or other metal objects.
 - b) Use tools with insulated handles.
 - c) Wear rubber gloves and boots.
 - d) Do not lay tools or metal parts on top of batteries.
 - e) Disconnect charging source prior to connecting or disconnecting battery terminals.

D) External Battery (10kVA, 20kVA, 30kVA, 40kVA and 50kVA)

Please refer to the following when installing and maintaining batteries:

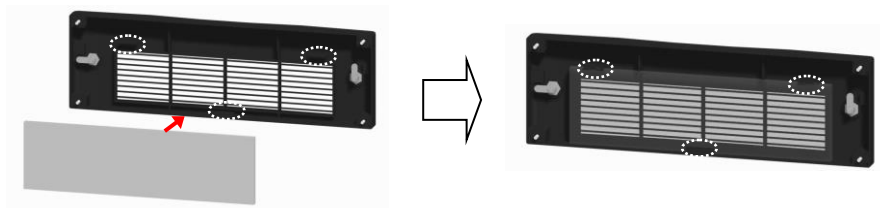


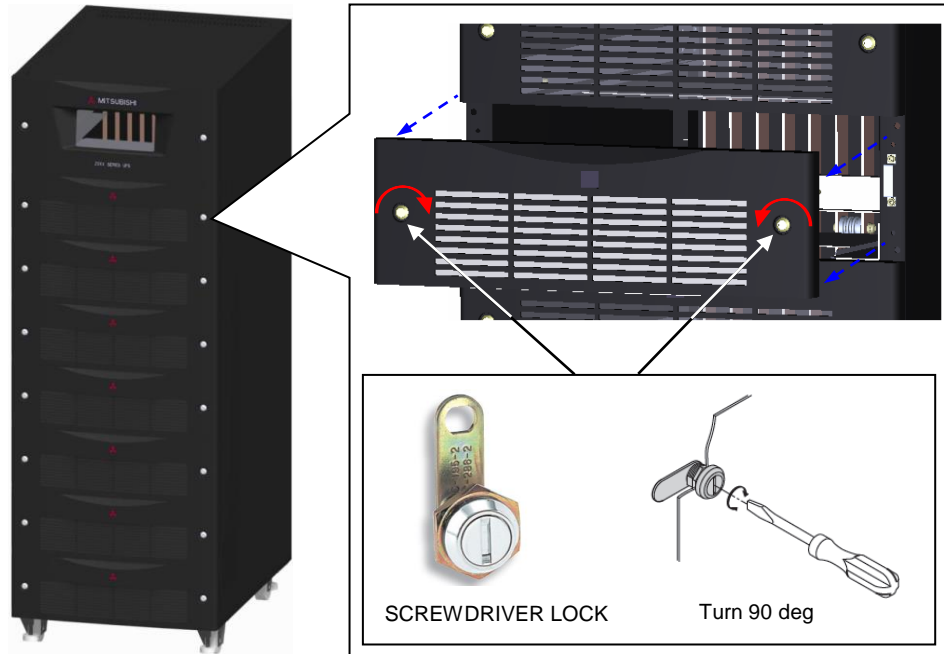
1. The customer shall refer to the battery manufacturer's installation manual for battery installation and maintenance instructions.
2. The maximum permitted fault current from the remote battery supply and the DC voltage rating of the battery supply over-current protective device is shown in Table 13.

▲ For other stored energy systems, refer to the supplement..

Table 13 Maximum Permitted Fault Current

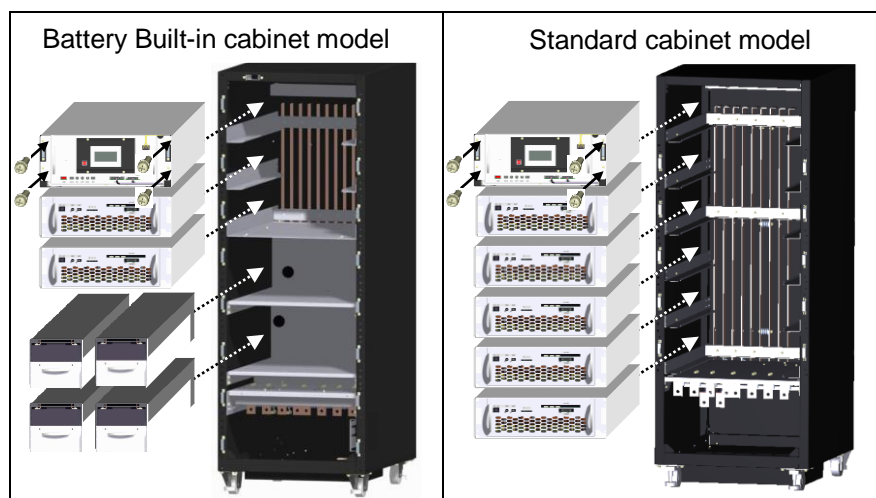
UPS Capacity (kVA)	DC Voltage Rating (V)	Maximum Fault Current Permitted (A)
10	288	25,000
20	288	25,000
30	288	25,000
40	288	25,000
50	288	25,000

E) Installing Air Filter
1. Remove front cover
2. Grip the air filter using three ledges
 Filter Size: 16W x 4.3H x 0.8D (in)

3. Close the front cover

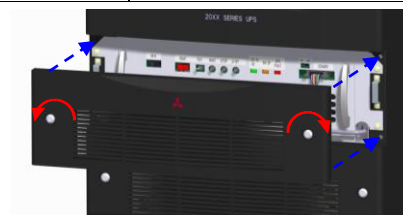
**F) Installing Power Converter Module and Bypass Module
(FOR SERVICE PERSONNEL ONLY)**
Figure 36 Install Power Converter Module and Bypass Module
**1. Remove
Front Cover**

2. Installing Modules

Quantity of Modules

	Bypass Module	Power Converter Module	Battery Tray
10kVA	One(1)	One(1)	Four(4) or None
20kVA	One(1)	Two(2)	Four(4) or None
30kVA	One(1)	Three(3)	None
40kVA	One(1)	Four(4)	None
50kVA	One(1)	Five(5)	None



3. Fasten four (4) screws in each module
4. Insert control wires
5. Close front cover



3.5 PROCEDURE FOR CABLE CONNECTIONS

1. Confirm the capacity of the UPS being installed. Identify the input/output power terminal blocks shown in Figure 38 or Figure 39.
2. Connect the grounding conductor from the input service entrance to the UPS ground bar.
3. Confirm that an external input circuit breaker sized to protect both the converter input and the bypass line is installed. Consult the equipment nameplate for current ratings. Connect the AC power source cables from the input service entrance to the UPS INPUT power terminals, identified as A10, B10, C10 and N10 in Figure 40. Input cables must be sized for an ampere rating larger than the maximum current capacity of the UPS.
4. Refer to Table 14 for recommended cable sizes. Referring to Figure 40, connect the UPS OUTPUT load terminals A40, B40, C40 and N10 to the load distribution panel.
5. Connect the external signal terminal block as needed. Refer to Section 2.3, Figure 28 and Figure 29 for functional descriptions. AWG12, or less, shielded conductor is recommended.


NOTE

NOTE: UPS power terminals are supplied with stud type fittings. It is recommended that compression lugs be used to fasten all input/output power cables. Refer to Table 15 for recommended compression lugs and appropriate crimping tool.

Table 14 Recommended Cable Size and Torque Requirements

UPS Capacity (kVA)	Input Side *1		DC Input Side		Output Side *1	
	Cable *2 Size	Torque (in. lbs)	Cable *2 Size	Torque (in. lbs)	Cable *2 Size	Torque (in. lbs)
10kVA	8 AWG or larger	135 in. lbs	8 AWG or larger	135 in. lbs	8 AWG or larger	135 in. lbs
20kVA	4 AWG or larger	135 in. lbs	4 AWG or larger	135 in. lbs	4 AWG or larger	135 in. lbs
30kVA	2 AWG or larger	135 in. lbs	1 AWG or larger	135 in. lbs	2 AWG or larger	135 in. lbs
40kVA	1/0 AWG or larger	135 in. lbs	2/0 AWG or larger	135 in. lbs	1/0 AWG or larger	135 in. lbs
50kVA	3/0 AWG or larger	135 in. lbs	4/0 AWG or larger	135 in. lbs	2/0 AWG or larger	135 in. lbs

*1 - Voltage drop across power cables shall not exceed 3% of nominal source voltage.

*2 - Allowable ampere ratings based on 90°C insulation at an ambient temperature of 40°C.

No more than 3 conductors in a raceway can be used without de-rating. Copper conductors are assumed.


NOTE

NOTE: If intending to upgrade to future input/output/battery wiring and branch circuit protection, specific renovations will be required.

Table 15 Crimp Type Compression Lug

WIRE SIZE (CODE)	WIRE STRAND CLASS	RECOMMENDATION		CRIMP TOOL REQUIRED BURNDY TYPE Y35 OR Y46	
		VENDOR	CAT. NO.	COLOR KEY	DIE INDEX
8	B	BURNDY	YA8CL-2TC38	RED	49
4	B	BURNDY	YA4CL-2TC38	GRAY	8
2	B	BURNDY	YA2CL-2TC38	BROWN	10
1	B	BURNDY	YA1CL-2TC38	GREEN	11
1/0	B	BURNDY	YA25L-2TC38	PINK	12
2/0	B	BURNDY	YA26L-2TC38	BLACK	13
3/0	B	BURNDY	YA27L-2TC38	ORANGE	14
4/0	B	BURNDY	YA28L-2TC38	PURPLE	15



NOTE: When using crimp type lugs, the lugs should be crimped to the specifications given in the manufacturer's instructions for both crimp tool and lug.

NOTE

Table 16 Recommended Hardware

UPS Capacity	Bolt size	Flat washer size	Split lockwasher size	Nut size
10kVA	M8 x 30mm	M8	M8	M8
20kVA	M8 x 30mm	M8	M8	M8
30kVA	M8 x 30mm	M8	M8	M8
40kVA	M8 x 30mm	M8	M8	M8
50kVA	M8 x 30mm	M8	M8	M8

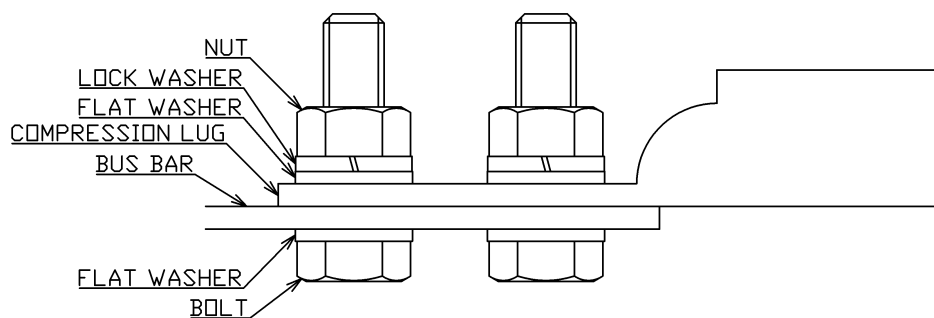
Figure 37 Hardware Configuration


Figure 38 UPS Terminal Designation Battery Built-In Cabinet Model (10kVA, 20kVA UPS)

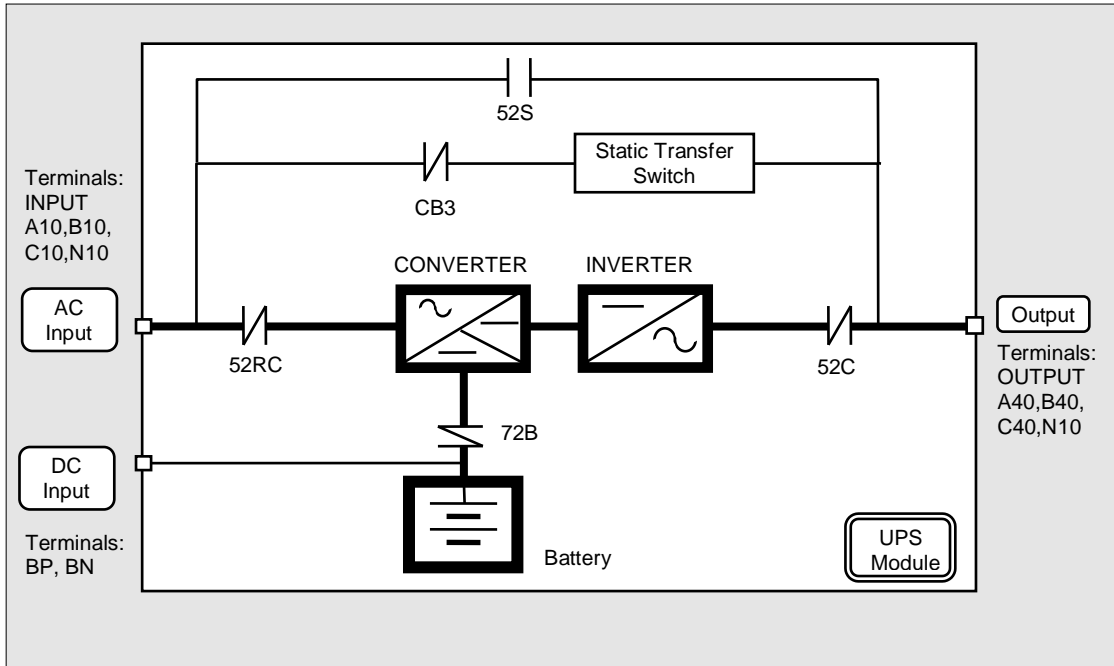


Figure 39 UPS Terminal Designation Standard Cabinet Model (10kVA, 20kVA, 30kVA, 40kVA, 50kVA UPS)

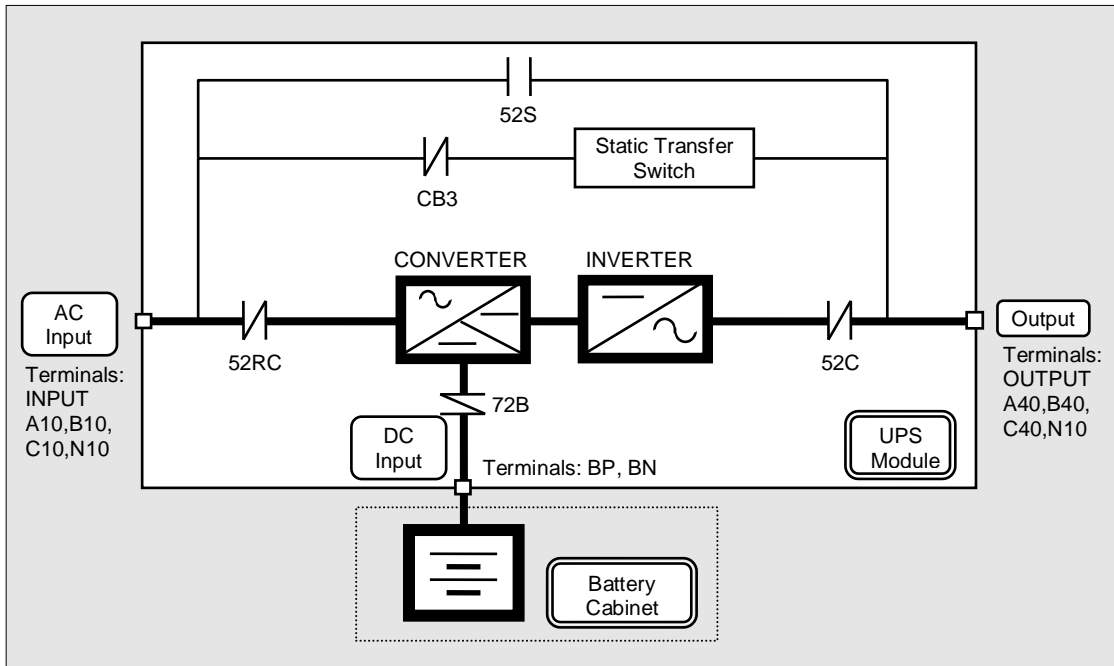
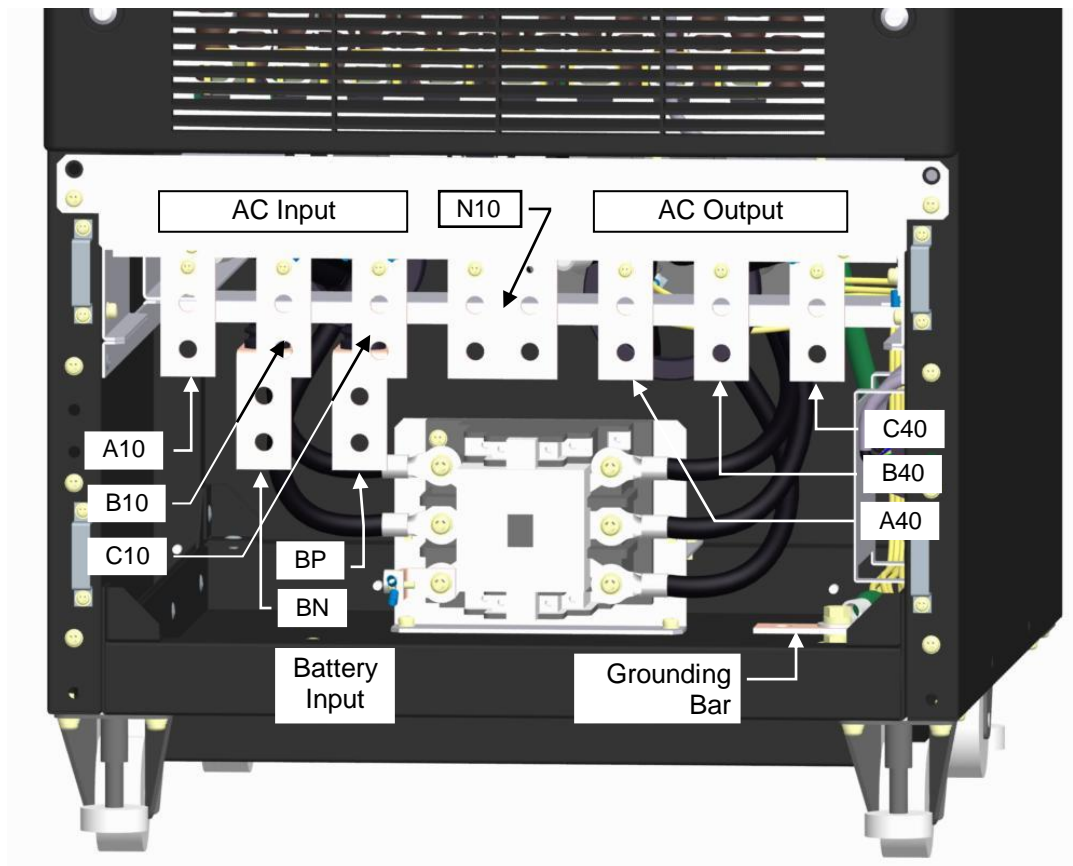


Figure 40 Input/Output Power Terminals



ALL POWER TERMINALS USE 5/16" (8 mm) DIAMETER BOLTS

3.6 OPERATING PROCEDURES

A) UPS Startup Procedure



CAUTION: Before the UPS startup, the internal bypass line starts to supply unconditioned bypass input power to the critical load when the external input circuit breaker is closed. Be extremely careful when closing the external input circuit breaker.



NOTE: When "REMOTE OPERATION MODE" is displayed on the LCD panel, the inverter start operation can only be performed remotely. If local inverter start operation is required at the UPS, select "LOCAL ONLY" or "REMOTE & LOCAL" in the OPERATION MENU.

1. Verify that the external input circuit breaker is closed (user supplied; refer to Warning 4).
2. The LCD panel boots up automatically and the screen will show that the load is powered through the bypass line.
3. On the LCD panel, press the "START/STOP" button to proceed UPS startup (refer to 2.2.1).
4. Follow the "STARTUP GUIDANCE" accordingly until the completion of the inverter startup.

B) UPS Shutdown Procedure



NOTE: When "REMOTE OPERATION MODE" is displayed on the LCD panel, the inverter start operation can only be performed remotely. If local inverter start operation is required at the UPS, select "LOCAL ONLY" or "REMOTE & LOCAL" in the OPERATION MENU.

1. On the LCD panel, press the "START/STOP" icon to proceed the UPS shutdown (refer to 2.2.1).
2. Follow the "SHUTDOWN GUIDANCE" accordingly. During the procedure, the UPS will transfer the power feeding from the inverter supply to the bypass line supply.
3. Both the converter and inverter will remain energized until complete disconnection from all power sources.

**WARNING**

WARNING: Verify that the load is OFF if the next step is to be performed.

**NOTE**

NOTE: Power to the critical load is supplied through the static bypass line. Power to the critical load will be lost after execution of the next step. The load will drop.

4. To shutdown the critical load, open the external input circuit breaker (user supplied).

**CAUTION**

CAUTION: In bypass mode, all UPS power terminals are still live. Lethal voltages are present. De-energize all external sources of AC and DC power. Before removing the covers, wait 5 minutes after de-energizing. Check that no voltage is flowing before handling the UPS. Be careful with the devices even when the UPS has been de-energized; the internal devices may still be hot.

C) EPO (Emergency Power Off) Procedure

If an all-power supply shutdown is required in an emergency situation, press the "EPO" button on the front panel. The UPS will be shutdown and no power is supplied to the load.

**WARNING**

WARNING: With EPO operation, although all output power from the UPS is shutdown, it is necessary to manually open the input circuit breaker (user supplied) to remove the input power to the UPS.

3.7 MAINTENANCE BYPASS SETUP PROCEDURES



NOTE

NOTE: Consult MITSUBISHI ELECTRIC POWER PRODUCTS, INC for an External Maintenance Bypass Panel at 1-800-887-7830.

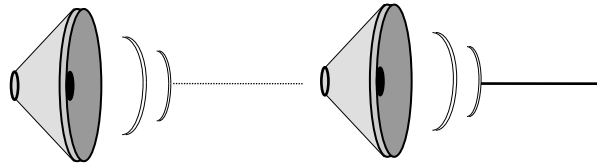
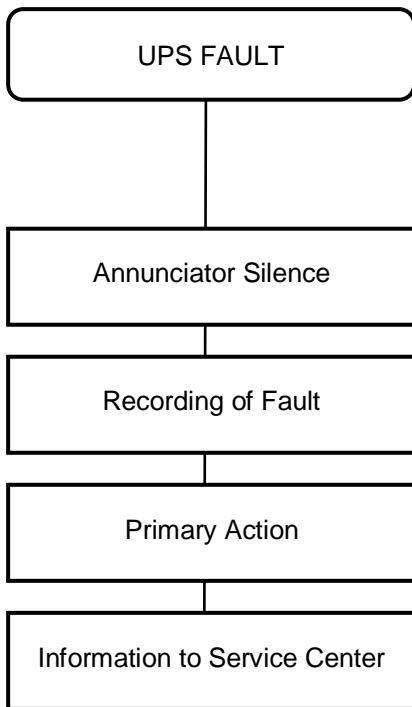
A) Load transfer from inverter to external maintenance bypass

1. On the LCD panel, press the "START/STOP" icon to proceed the UPS shutdown (note: the inverter STOP function is inhibited if the bypass and inverter are out of sync).
2. Confirm via the flow diagram on the LCD that the load is fed from the UPS static bypass line.
3. Close the maintenance bypass circuit breaker in the external maintenance bypass panel (MBP).
4. Open the UPS output circuit breaker in the MBP.
5. Transfer is complete. The load is now powered from the external source. The UPS can be shutdown.

B) Transfer of load from external maintenance bypass to inverter

1. Verify that the external input circuit breaker is closed.
2. Confirm via the flow diagram on the LCD that the UPS output is fed from the static bypass line.
3. Close the UPS output circuit breaker in the MBP.
4. Open the Maintenance bypass circuit breaker in the MBP.
5. On the LCD panel, press the "START/STOP" button to proceed the UPS startup (refer to 2.2.1).
6. Transfer is complete. The load now is powered by the inverter.

4 RESPONSE TO UPS FAILURE



Press “SILENCE ALARM” icon on Main Menu.

Refer to the list of fault codes in Section 6 for error description.

Take necessary action according to display guidance.

When faults happen, contact the Authorized Mitsubishi Electric Service Representatives or call Mitsubishi Electric at **1-800-887-7830**.



NOTE

NOTE:

The error code indicated on the LCD display panel when a UPS alarms is very important.

In order to reduce repair time, please include this information, along with the operation and load status in all correspondence to Mitsubishi Electric Field Service Group.

5 PARTS REPLACEMENT

Contact Mitsubishi Electric Power Products, Inc. or its authorized service representatives on all issues regarding the replacement of parts at 1-800-887-7830.

A) Battery ▲

Battery lifetime may vary according to the frequency of use and the average ambient operating temperature. The end of battery life is defined as the state of charge resulting in an ampere-hour capacity less than, or equal to, 80% of nominal capacity.

Replace the battery if its capacity is within this percentage.

B) UPS Component Parts

UPS components have a defined life expectancy (Capacitors, Filters, etc.).

Contact Mitsubishi Electric Power Products, Inc. or its authorized service representatives for a complete parts replacement schedule. The recommended replacement time interval varies with the operating environment.

Contact Mitsubishi Electric Power Products, Inc. or its authorized service representatives for application-specific recommendations.



NOTE

NOTE: Any part replacements (including modifications) without authorization by Mitsubishi Electric could result in personal injuries, death or destruction of the UPS.

▲ For other stored energy systems, refer to the supplement..

6 FAULT CODES

This section covers fault codes, their descriptions and required actions.

In the event of a fault:

Verify and record the occurrence of the alarm. Note the details of all alarm messages displayed on the LCD display panel.

**Contact Mitsubishi Electric Power Products, Inc. at
1-800-887-7830.**

6.1 BYPASS MODULE FAULT CODES
Table 17 Bypass Module Fault Code List

Code indication (Note 2)	Status Message	Meaning	Guidance	Audible Alarm	External relay contact (Note 1)
UA805	INVERTER OVERLOAD	The output load current has exceeded 100% of the rated current.	WARNING: DECREASE LOAD	Intermittent sound	Overload Warning
UA806	INVERTER OVERLOAD	The output load current peak has exceeded 220% of the rated current.	WARNING: DECREASE LOAD	Intermittent sound	Overload Warning
UA807	INVERTER OVERLOAD	The output load current has exceeded 105% of the rated current.	WARNING: DECREASE LOAD	Intermittent sound	Overload
UA808	INVERTER OVERLOAD	The output load current has exceeded 100% of the rated current during bypass supply.	WARNING: DECREASE LOAD	Intermittent sound	Overload
UA812	BYPASS VOLTAGE OUT OF RANGE	Bypass line voltage is out of the specific range.	CHECK BYPASS INPUT	Intermittent sound	Bypass Input Abnormal
UA813	BYPASS PHASE ROTATION ERROR	Bypass line power conductors are not wired in a proper phase sequence.	CHECK BYPASS INPUT	Intermittent sound	Bypass Input Abnormal
UA814	BYPASS FREQUENCY OUT OF RANGE	Bypass line frequency is out of the specific range.	CHECK BYPASS INPUT	Intermittent sound	Bypass Input Abnormal
UA817	EMERGENCY STOP ACTIVATED	The emergency stop was activated by the EPO switch or an external contact.	-	Continuous sound	Alarm
UA819	REMOTE BUTTON ABNORMAL	Remote start signal is being received continuously for a considerable time.	-	Intermittent sound	Alarm
UA820	LOCAL BUTTON ABNORMAL	Local start or stop signal is being received continuously for a considerable time.	CALL SERVICE ENGINEER	Intermittent sound	Alarm
UA821	TRANSFER INHIBITION	The UPS cannot transfer to the bypass because the inverter output is not synchronized to the bypass.	-	-	Alarm
UA822	TRANSFER INHIBITION	The UPS cannot transfer to the bypass because of backup generator operation.	-	-	Alarm
UA824	72B OPEN	The battery disconnect contactor 72B in power converter module is opened.	-	-	Alarm
UA830	INTERLOCK SWITCH ON	Interlock switch was turned on.	-	Intermittent sound	Alarm
UA831	EMERGENCY BYPASS SWITCH ON	Emergency bypass switch has been turned on.	-	Intermittent sound	Alarm
UA834	BATTERY DEPLETED/AC OUT STOPPED	The battery voltage has reached the depleted level.	CALL SERVICE ENGINEER	Continuous sound	End-of- Discharge
UA835	TRANSFER INHIBITION	The UPS could not transfer to the bypass because the bypass source has an abnormality.	-	-	Alarm
UA861	MODULE ALARM	A power converter module has detected an alarm condition.	CALL SERVICE ENGINEER	Intermittent sound	Alarm
UA862	MODULE MINOR FAULT	A power converter module has detected a minor fault condition.	CALL SERVICE ENGINEER	Intermittent sound	Alarm
UA863	MODULE INPUT VOLTAGE OUT OF RANGE	A power converter module has detected input voltage abnormal.	CHECK INPUT POWER SOURCE	Intermittent sound	Alarm
UA864	MODULE OVERLOAD	A power converter module has detected output overload.	WARNING : DECREASE LOAD	Intermittent sound	Alarm

Code indication (Note 2)	Status Message	Meaning	Guidance	Audible Alarm	External relay contact (Note 1)
UA865	MODULE BATTERY DEPLETED	A power converter module has detected battery depleted.	CALL SERVICE ENGINEER	Intermittent sound	Alarm
UA866	MODULE BATTERY DEPLETED ALARM	A power converter module issues a warning on eminent battery depletion.	CALL SERVICE ENGINEER	Intermittent sound	Alarm
UA891	CHG. PROHIBITED	The relay turned on.	-	Intermittent sound	Alarm
UA892	DISCHG. PROHIBITED	The relay turned on.	-	Intermittent sound	Alarm
UF055	CONVERTER ABNORMAL	Mixed operation (20 seconds)	CALL SERVICE ENGINEER	Intermittent sound	Minor
UF151	BATTERY VOLTAGE ABNORMAL	All power converter modules have detected battery float voltage abnormal.	CALL SERVICE ENGINEER	Intermittent sound	Minor
UF156	CHG.STOPPED (BATTERY OVERTEMP.)	UF157 failure persisted for over two(2) hours.	CHECK BATTERY	Intermittent sound	Battery abnormal
UF157	BATTERY OVERTEMPERATURE	Detection of overtemperature at the batteries.	CHECK BATTERY	Intermittent sound	Battery abnormal
UF158	BATTERY LIQUID LOW	Low level of battery electrolyte solution.	CHECK BATTERY	Intermittent sound	Battery abnormal
UF161	CHG.STOPPED (DC VOLT. ABNORMAL)	UF151 failure is running for over 24 hours.	CALL SERVICE ENGINEER	Intermittent sound	Battery abnormal
UF162	BATTERY ABNORMAL	Failure detection based on battery self-check.	CALL SERVICE ENGINEER	Intermittent sound	Battery abnormal
UF163	BATTERY VOLTAGE ABNORMAL	All converter modules have detected battery voltage abnormal.	CALL SERVICE ENGINEER	Intermittent sound	Battery abnormal
UF202	OUTPUT UNDERVOLTAGE	Output voltage dropped.	CALL SERVICE ENGINEER	Intermittent sound	Minor
UF253	UPS CONTROL CIRCUIT ERROR	Discrepancy between output voltage and bypass voltage during bypass operation.	CALL SERVICE ENGINEER	Intermittent sound	Minor
UF254	UPS CONTROL CIRCUIT ERROR	Inverter voltage is out of the specification level during transfer.	CALL SERVICE ENGINEER	Intermittent sound	Minor
UF256	OUTPUT VOLTAGE ABNORMAL	Output voltage is out of the specified range.	CALL SERVICE ENGINEER	Intermittent sound	Minor
UF258	LOAD ABNORMAL	Load transfer due to overload for over 4 times within 5 minutes.	CALL SERVICE ENGINEER	Intermittent sound	Minor
UF301	UPS CONTROL CIRCUIT ERROR	AD reference has an abnormal value.	CALL SERVICE ENGINEER	Continuous sound	Major
UF302	UPS CONTROL CIRCUIT ERROR	Detection of an external interruption during the software execution.	CALL SERVICE ENGINEER	Continuous sound	Major
UF303	UPS CONTROL CIRCUIT ERROR	Timer does not reset in the specified period (WDT settings)	CALL SERVICE ENGINEER	Continuous sound	Major
UF305	UPS CONTROL CIRCUIT ERROR	Detection of an abnormal clock speed in the CPU or FPGA.	CALL SERVICE ENGINEER	Continuous sound	Major
UF306	UPS CONTROL CIRCUIT ERROR	Control power supply voltage is below the specified level.	CALL SERVICE ENGINEER	Continuous sound	Major
UF320	UPS CONTROL CIRCUIT ERROR	Cable disconnection in the parallel interface board during load supply.	CALL SERVICE ENGINEER	Intermittent sound	Minor

Code indication (Note 2)	Status Message	Meaning	Guidance	Audible Alarm	External relay contact (Note 1)
UF323	UPS CONTROL CIRCUIT ERROR	Major communication error during parallel operation.	CALL SERVICE ENGINEER	Intermittent sound	Minor
UF340	MODULE MINOR FAULT	A power converter module has detected major fault condition.	CALL SERVICE ENGINEER	Intermittent sound	Minor
UF341	MODULE1 MAJOR FAULT	Power converter module #1 has detected major fault condition.	CALL SERVICE ENGINEER	Intermittent sound	Minor
UF342	MODULE2 MAJOR FAULT	Power converter module #2 has detected major fault condition.	CALL SERVICE ENGINEER	Intermittent sound	Minor
UF343	MODULE3 MAJOR FAULT	Power converter module #3 has detected major fault condition.	CALL SERVICE ENGINEER	Intermittent sound	Minor
UF344	MODULE4 MAJOR FAULT	Power converter module #4 has detected major fault condition.	CALL SERVICE ENGINEER	Intermittent sound	Minor
UF345	MODULE5 MAJOR FAULT	Power converter module #5 has detected major fault condition.	CALL SERVICE ENGINEER	Intermittent sound	Minor
UF349	MODULE MAJOR FAULT	All Power converter modules have detected major fault condition.	CALL SERVICE ENGINEER	Continuous sound	Major
UF351	CONTROL POWER SUPPLY ABNORMAL	Control power supply voltage is below the specified level. (Bypass)	CALL SERVICE ENGINEER	Intermittent sound	Minor
UF352	CONTROL POWER SUPPLY ABNORMAL	Control power supply voltage is below the specified level. (Output)	CALL SERVICE ENGINEER	Intermittent sound	Minor
UF353	EXTERNAL I/F PCB ABNORMAL	External IO control power supply voltage is below the specified level.	CALL SERVICE ENGINEER	Intermittent sound	Minor
UF372	UPS CONTROL CIRCUIT ERROR	Unable to synchronize the inverter output and the bypass voltage.	CALL SERVICE ENGINEER	Intermittent sound	Minor
UF376	UPS CONTROL CIRCUIT ERROR	Logic signal abnormal (Supply ON).	CALL SERVICE ENGINEER	Intermittent sound	Minor
UF377	UPS CONTROL CIRCUIT ERROR	Logic signal abnormal (Supply OFF).	CALL SERVICE ENGINEER	Intermittent sound	Minor
UF401	52S ABNORMAL	Error to close the contactor 52S.	CALL SERVICE ENGINEER	Continuous sound	Major
UF402	52S ABNORMAL	Error to open the contactor 52S.	CALL SERVICE ENGINEER	Continuous sound	Major
UF452	CB3 ABNORMAL	Contactor CB3 is not working properly.	CALL SERVICE ENGINEER	Intermittent sound	Minor

6.2 POWER CONVERTER MODULE FAULT CODES
Table 18 Converter Module Fault Code List

Code indication (Note 2)	Status message	Meaning	External relay contact (Note 1)
MA801	AC INPUT VOLTAGE OUT OF RANGE	Input line voltage is out of the specific range.	Alarm AC input abnormal
MA802	AC INPUT FREQUENCY OUT OF RANGE	Input line frequency is out of the specified range.	Alarm AC input abnormal
MA803	AC INPUT PHASE ROTATION ERROR	Input line power conductors are not wired in a proper phase sequence.	Alarm AC input abnormal
MA804	CONVERTER OPE. INHIBITION	The converter interlock is active.	Alarm
MA806	INVERTER OVERLOAD	The inverter output current has exceeded 110% for 1 min. or 130% for 30sec. of the rated current.	Alarm Overload
MA807	INVERTER OVERLOAD	The inverter output current has exceeded 110% of the rated current.	Alarm Overload
MA810	INVERTER OVERLOAD	Short time over-current has exceeded 150% of the rated current	Alarm Overload
MA817	EMERGENCY STOP ACTIVATED	The emergency stop was activated by the EPO switch or an external contact.	Alarm
MA824	72B OPEN	The battery disconnect contactor 72B open.	Alarm
MA825	BATTERY ABNORMAL	Battery voltage is less than end voltage at startup.	Alarm
MA828	COOLING FAN ABNORMAL	Rotation sensor detect fan abnormal.	Alarm
MA834	BATTERY DEPLETED	The battery voltage has reached the depleted level.	Major End-of-Discharge
MA836	INVERTER OVERLOAD	The output load active power has exceeded 110% of the rated current.	Alarm Overload
MA866	UPS CONTROL CIRCUIT ERROR	Communication signal was lost from the bypass module.	Minor
MF001	INPUT CIRCUIT ABNORMAL	Detection of a large variation of the reference error signal.	Major
MF002	CONVERTER OVERCURRENT	Detection of converter overcurrent.	Major
MF003	PRECHARGE FAULT	Pre-charging circuit is not working properly.	Major
MF102	DC OVERVOLTAGE	DC voltage surpasses the overvoltage level.	Major
MF103	DC UNDERVOLTAGE	DC voltage dropped below the undervoltage level.	Major
MF104	DISCHARGE FAULT	Capacitor voltage is higher than 100V at 5 minutes after module stop.	Major
MF108	CHOPPER OVERCURRENT	Detection of DC overcurrent.	Major

Code indication (Note 2)	Status message	Meaning	External relay contact (Note 1)
MF109	DC UNBALANCED	Major unbalance of the neutral point voltage.	Major
MF112	DC CIRCUIT ABNORMAL	Sudden change of the DC voltage level.	Major
MF128	CONTROL POWER SUPPLY ABNORMAL	Power supply voltage to IGBT driver PCB is below the specified level.	Major
MF162	BATTERY ABNORMAL	Failure detection based on battery self-check.	Minor
MF163	BATTERY VOLTAGE ABNORMAL	Battery voltage is abnormal.	Minor
MF169	BATTERY VOLTAGE ABNORMAL	Battery voltage is abnormal.	Minor
MF170	VDB SENSOR ABNORMAL	Detection of a large variation of the difference between control-only and protection-only battery voltage.	Minor
MF201	INVERTER OVERVOLTAGE	Detection of output overvoltage.	Major
MF202	INVERTER UNDERVOLTAGE	Output voltage dropped.	Major
MF203	INVERTER OVERCURRENT	Detection of inverter overcurrent.	Major
MF204	OUTPUT CIRCUIT ABNORMAL	Detection of a large variation of the reference error signal (current reference and actual current).	Minor
MF206	UPS CONTROL CIRCUIT ERROR	Discrepancy between output voltage and external voltage (bypass, common ac bus)	Major
MF208	UPS CONTROL CIRCUIT ERROR	Cross current is abnormal.	Major
MF210	52C ABNORMAL	Error to open the contactor 52C.	Major
MF213	OVERTEMPERATURE	Heatsink temperature exceeds thermal settings.	Major
MF214	COOLING FAN ABNORMAL	Thermal relay activated protection.	Major
MF253	UPS CONTROL CIRCUIT ERROR	Discrepancy between output voltage and inverter voltage, or between output voltage and bypass voltage.	Minor
MF301	UPS CONTROL CIRCUIT ERROR	AD reference has an abnormal value.	Major
MF302	UPS CONTROL CIRCUIT ERROR	Detection of an external interruption during the software execution.	Major
MF303	UPS CONTROL CIRCUIT ERROR	Timer does not reset in the specified period (WDT settings)	Major
MF305	UPS CONTROL CIRCUIT ERROR	Detection of an abnormal clock speed in the DSP or FPGA.	Major
MF306	UPS CONTROL CIRCUIT ERROR	Control power supply voltage is below the specified level.	Major
MF309	INVERTER VOLTAGE ABNORMAL	Inverter voltage is out of the specified range.	Major

Code indication (Note 2)	Status message	Meaning	External relay contact (Note 1)
MF320	UPS CONTROL CIRCUIT ERROR	Cable disconnection in the parallel interface board during load supply.	Major
MF376	UPS CONTROL CIRCUIT ERROR	Logic signal abnormal (Supply ON)	Minor
MF552	DUMMY FAULT	Bypass Module send fault simulation signal.	Major

- (Note 1) 1) "Major" is defined as a major failure. The load is transferred from the inverter circuit to the static bypass line.
 2) "Minor" is defined as a minor failure. The UPS continues to operate normally, but the cause of alarm must be identified.

(Note 2) Code indication means:

#A+++ ----- Alarm
 #F+++ ----- Failure
 #%0++ ----- Rectifier circuit failure
 #%1++ ----- DC circuit failure
 #%2++ ----- Inverter circuit failure
 #%3++ ----- Control circuit failure
 #%4++ ----- Bypass system failure
 #%8++ ----- Alarm

"#" Bypass Module "U", Power Converter Module "M"

"+" denotes any numeral from 0 to 9

"%" denotes either "A" or "F"

7 WARRANTY & OUT OF WARRANTY SERVICE

Important Warranty Information

- For customers purchasing a new Uninterruptible Power Supply (UPS) directly from Mitsubishi Electric Power Products, Inc., the Limited Warranty of your Uninterruptible Power Supply (UPS) was provided to you at the time of sale.
- For customers purchasing a new Uninterruptible Power Supply (UPS) from a Reseller, the Limited Warranty of your Uninterruptible Power Supply (UPS) was provided to the Reseller at the time of sale. Please contact Mitsubishi Electric Power Products Inc. immediately if formal documentation of the warranty transfer was not provided to you.
- To ensure prompt support please update your Product Registration information www.mitsubishicritical.com/registration at completion of startup and whenever the registered contacts responsible for your UPS change.
- Additional copies of our Limited Warranty and your Product Registration are available upon request at www.mitsubishicritical.com/registration or calling 1-800-887-7830 or 1-724-772-2555.

8 MAINTENANCE CONTRACTS

For information on maintenance contracts and other service offerings, please visit www.mitsubishicritical.com/services.

