

CIRCUIT BREAKER SUMMARY				
BREAKER TYPE	BREAKER MODEL	TRIP	AIC	WIRE RANGE
EATON SERIES C	HFDDC3XXX	15-100A	42K @ 600VDC	(1) 14 - 1/0 ①
EATON SERIES G	JGEDC3XXX	125-250A	35K @ 600VDC	(1) 8 - 350 ①
	LGEDC3XXX	300-350A	35K @ 600VDC	(1) 3 - 500 ①
	LGEDC3400	400A	35K @ 600VDC	(1) 500 - 750 ①

① THIS SPECIFIES THE WIRE RANGE THAT CAN BE USED WITH THE CIRCUIT BREAKER LUG. THE WIRE SHALL BE SIZED IN ACCORDANCE WITH THE MOST RECENT REVISION OF THE NATIONAL ELECTRICAL CODE (NEC) NFPA 70.

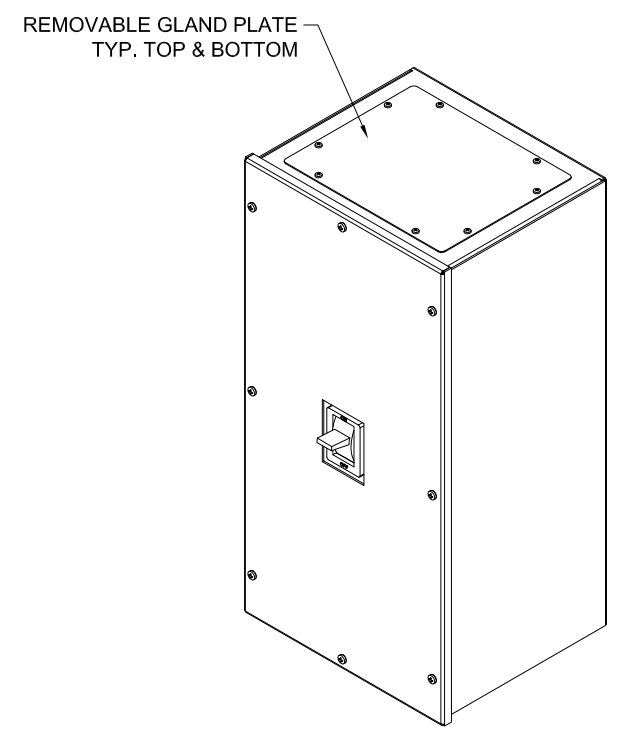
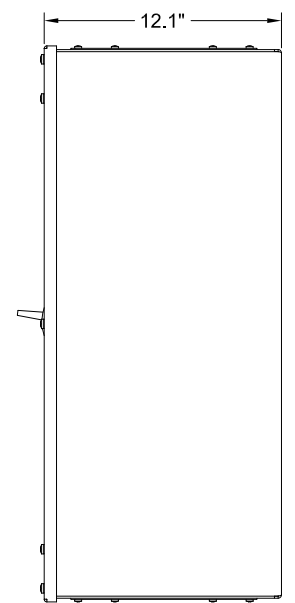
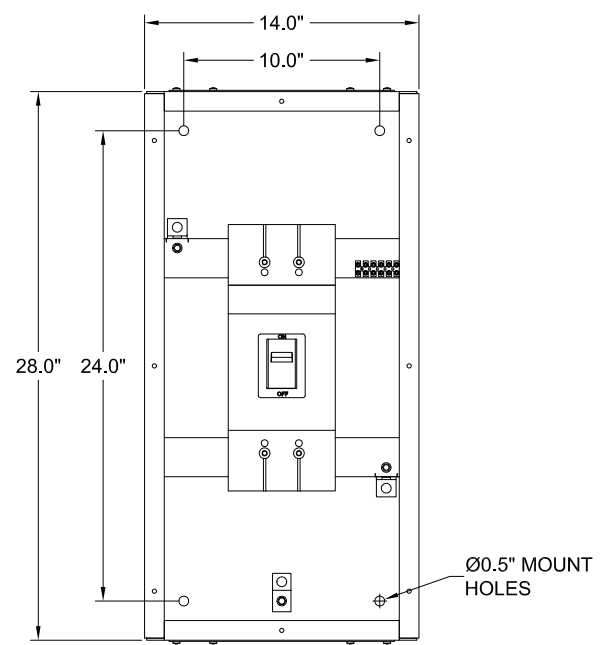
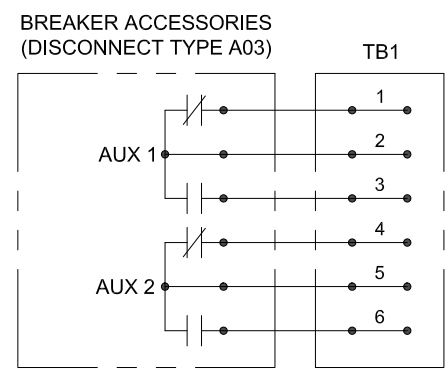

- NOTES:**
- APPROXIMATE WEIGHT: 70 LBS.
 - ASSEMBLY IS LISTED TO UL/CUL 1778 & CSA C22.2 NO. 107.3.
 - NEMA 1 WALL MOUNT ENCLOSURE.
 - HEAVY GAUGE WELDED STEEL CONSTRUCTION.
 - POWDER COAT FINISH ON EXTERIOR AND INTERIOR OF CABINET.
 - A MINIMUM CLEARANCE OF 36" IS REQUIRED AT THE FRONT OF THE EQUIPMENT.
 - ALL INTERNAL WIRING IS UL LISTED MTW STYLE 600V 105C RATED.
 - BREAKER IS UL LISTED.
 - BREAKER ACCESSORY TERMINAL BLOCK IS UL RECOGNIZED, 600V RATED.
 - BREAKERS ARE SHIPPED IN THE OFF POSITION.
 - THREE GROUND LUGS ARE PROVIDED. EACH GROUND LUG ACCEPTS (1) #6-300 MCM CABLE.
 - ALL CONTROL WIRING IS POWERED FROM AN OUTSIDE SOURCE.
 - FOR TERMINAL BLOCK TORQUE INFORMATION REFER TO THE ACCESSORY BLOCK WIRING LABEL LOCATED INSIDE THE EQUIPMENT.
 - FOR CIRCUIT BREAKER ACCESSORY AND TORQUE INFORMATION REFER TO THE CIRCUIT BREAKER INFO LABEL LOCATED INSIDE THE EQUIPMENT.

PART NUMBER BREAK DOWN
DCDW-B0225E0350102A01

- TABLE CODE: A01 A03
- MFR
- NUMBER OF PROVISIONS
- KAIC RATING: 035
- BREAKER MANUFACTURER: E = EATON
- BREAKER RATING (A): 0015 - 0400
- COLOR: A BEIGE, B BLACK

REVISIONS	REF. DWG. No.	APPROVED: PB	DATE 11/29/21	<p>MITSUBISHI ELECTRIC POWER PRODUCTS, INC. WARRENDALE, PA.</p> <p>TITLE: DC DISCONNECT 15A-400A</p> <p>DWG No. SHEET 1 OF 1 REV: 3</p> <p>FILE LOCATION: 91810-M-SD01-1</p>
	DATE 11/29/21	CHECKED: PB	DATE 11/29/21	
	DATE 11/29/21	ENGINEER: CH	DATE 11/29/21	
	DATE 11/29/21	DRAFTER: CH	DATE 11/29/21	